

BINKS **AX85SD AIR MOTOR ASSEMBLY**
Patent 7,603,855

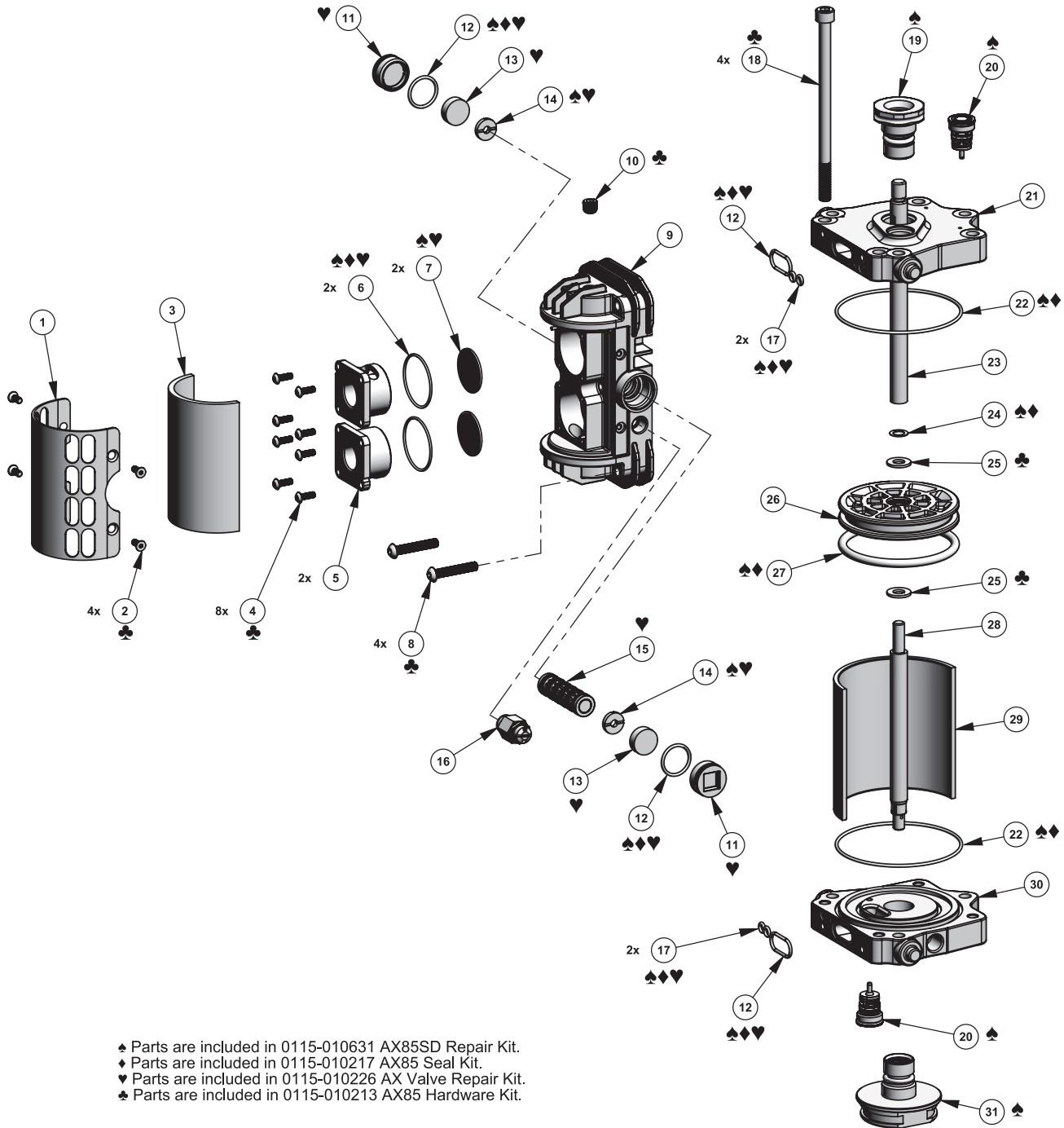

SPECIFICATIONS	
Maximum air inlet pressure:	116 psi (8 bar)
Maximum recommended continuous cycle rate:	20 cycles/min
Air consumption @ 20 cycles/min and 116 psi (8 bar) air inlet pressure:	5.2 SCFM (147 LPM)
Maximum operating temperature:	160°F (71°C)
Air inlet connection:	3/8" BSP (F)
Piston diameter:	3.3 in (85 mm)
Stroke length:	3 in. (75 mm)
Sound level:	96.2 dB
Weight:	6.5 lbs (2.9 kg)

AX85SD AIR MOTOR ASSEMBLY



AX85SD AIR MOTOR ASSEMBLY

ITEM NO.	PART NUMBER	DESCRIPTION	QTY.
1	0115-010023	EXHAUST COVER SCREEN	1
2	0115-010024 ♣	M4 x 10 FLAT HEAD SCREW	4
3	0115-010022	EXHAUST COVER	1
4	0115-010073 ♣	M4 X 12 BUTTON HEAD SCREW	8
5	0115-010019	QUICK EXHAUST VALVE CAGE	2
6	0115-010021 ♠♦♥	O-RING	2
7	0115-010020 ♠♥	DIAPHRAGM	2
8	0115-010026 ♣	M6 x 35 BUTTON HEAD SCREW	4
9	0115-010097	VALVE BLOCK ASSEMBLY	1
10	0115-010107 ♣	1/8 BSPT PIPE PLUG	1
11	0115-010018 ♥	VALVE BLOCK END CAP	2
12	0115-010049 ♠♦♥	O-RING	4
13	0115-010017 ♥	MAGNET	2
14	0115-010016 ♠♥	BUMPER	2
15	0115-010015 ♥	SPOOL AND SLEEVE ASSEMBLY	1
16	0114-014774	SAFETY VALVE	1
17	0115-010051 ♠♦♥	O-RING	4
18	0115-010029 ♣	M8 X 135 CAP SCREW	4
19	0115-010392 ♠	MOTOR ROD CARTRIDGE ASSEMBLY	1
20	0115-010037 ♠	POPPET ASSEMBLY	2
21	0115-010328	UPPER END CAP	1
22	0115-010050 ♠♦	O-RING	2
23	0115-010395	UPPER MOTOR ROD	1
24	0115-010036 ♠♦	SEALING RING	1
25	0115-010035 ♣	M8 WASHER	2
26	0115-010336	PISTON ASSEMBLY	1
27	0114-014466 ♠♦	O-RING	1
28	0115-010713	MOTOR ROD	1
29	0115-010003	CYLINDER	1
30	0115-010006	LOWER END CAP	1
31	0115-010657 ♠	MOTOR ROD CARTRIDGE ASSEMBLY	1

♠ Parts are included in 0115-010631 AX85SD Repair Kit.

♦ Parts are included in 0115-010217 AX85 Seal Kit.

♥ Parts are included in 0115-010226 AX Valve Repair Kit.

♣ Parts are included in 0115-010213 AX85 Hardware Kit.

Items 1 through 16 also available as an assembly: 0115-010660

In this part sheet, the words **WARNING**, **CAUTION** and **NOTE** are used to emphasize important safety information as follows:

WARNING

Hazards or unsafe practices which could result in severe personal injury, death or substantial property damage.

CAUTION

Hazards or unsafe practices which could result in minor personal injury, product or property damage.

NOTE

Important installation, operation or maintenance information.

WARNING

Read the following warnings before using this equipment.



READ THE MANUAL

Before operating finishing equipment, read and understand all safety, operation and maintenance information provided in the operation manual.



OPERATOR TRAINING

All personnel must be trained before operating finishing equipment.



EQUIPMENT MISUSE HAZARD

Equipment misuse can cause the equipment to rupture, malfunction, or start unexpectedly and result in serious injury.



LOCK OUT / TAG-OUT

Failure to de-energize, disconnect, lock out and tag-out all power sources before performing equipment maintenance could cause serious injury or death.



AUTOMATIC EQUIPMENT

Automatic equipment may start suddenly without warning.



PRESSURE RELIEF PROCEDURE

Always follow the pressure relief procedure in the equipment instruction manual.



KEEP EQUIPMENT GUARDS IN PLACE

Do not operate the equipment if the safety devices have been removed.



KNOW WHERE AND HOW TO SHUT OFF THE EQUIPMENT IN CASE OF AN EMERGENCY



WEAR SAFETY GLASSES

Failure to wear safety glasses with side shields could result in serious eye injury or blindness.



INSPECT THE EQUIPMENT DAILY

Inspect the equipment for worn or broken parts on a daily basis. Do not operate the equipment if you are uncertain about its condition.



NEVER MODIFY THE EQUIPMENT

Do not modify the equipment unless the manufacturer provides written approval.



NOISE HAZARD

You may be injured by loud noise. Hearing protection may be required when using this equipment.

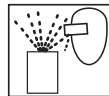

PROJECTILE HAZARD

You may be injured by venting liquids or gases that are released under pressure, or flying debris.



PINCH POINT HAZARD

Moving parts can crush and cut. Pinch points are basically any areas where there are moving parts.



STATIC CHARGE

Fluid may develop a static charge that must be dissipated through proper grounding of the equipment, objects to be sprayed and all other electrically conductive objects in the dispensing area. Improper grounding or sparks can cause a hazardous condition and result in fire, explosion or electric shock and other serious injury.



WEAR RESPIRATOR

Toxic fumes can cause serious injury or death if inhaled. Wear a respirator as recommended by the fluid and solvent manufacturer's Safety Data Sheet.



TOXIC FLUID & FUMES

Hazardous fluid or toxic fumes can cause serious injury or death if splashed in the eyes or on the skin, inhaled, injected or swallowed. LEARN and KNOW the specific hazards or the fluids you are using.



FIRE AND EXPLOSION HAZARD

Improper equipment grounding, poor ventilation, open flame or sparks can cause a hazardous condition and result in fire or explosion and serious injury.



MEDICAL ALERT

Any injury caused by high pressure liquid can be serious. If you are injured or even suspect an injury:

- Go to an emergency room immediately.
- Tell the doctor you suspect an injection injury.
- Show the doctor this medical information or the medical alert card provided with your airless spray equipment.
- Tell the doctor what kind of fluid you were spraying or dispensing.



GET IMMEDIATE MEDICAL ATTENTION

To prevent contact with the fluid, please note the following:

- Never point the gun/valve at anyone or any part of the body.
- Never put hand or fingers over the spray tip.
- Never attempt to stop or deflect fluid leaks with your hand, body, glove or rag.
- Always have the tip guard on the spray gun before spraying.
- Always ensure that the gun trigger safety operates before spraying.

IT IS THE RESPONSIBILITY OF THE EMPLOYER TO PROVIDE THIS INFORMATION TO THE OPERATOR OF THE EQUIPMENT. FOR FURTHER SAFETY INFORMATION REGARDING THIS EQUIPMENT, SEE THE GENERAL EQUIPMENT SAFETY BOOKLET (77-5300).

AX85SD AIR MOTOR ASSEMBLY

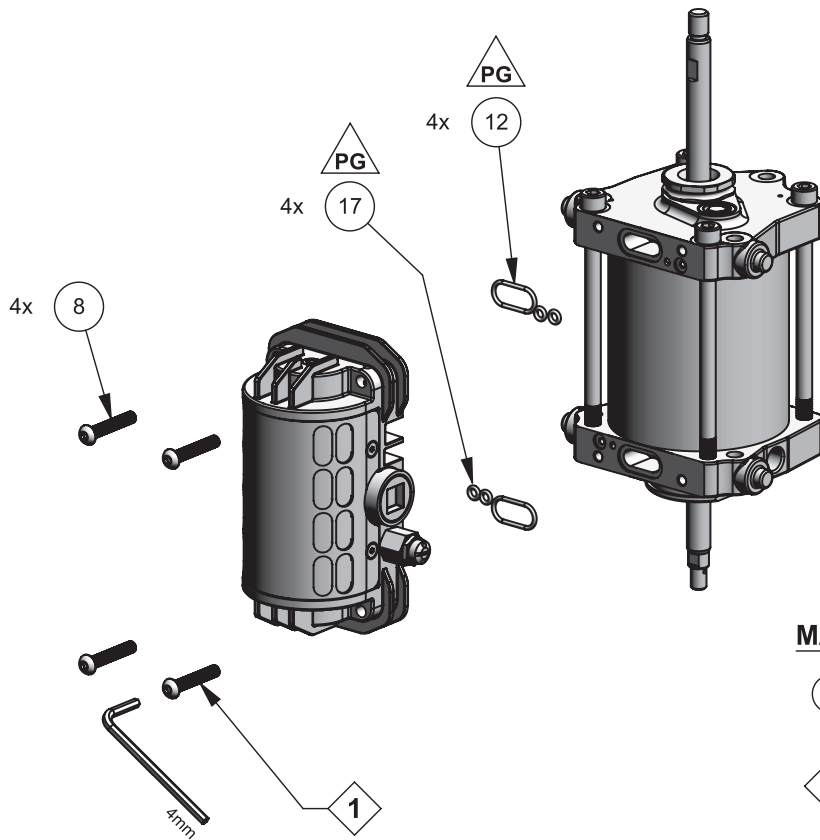

MAINTENANCE SYMBOLS:

- = ITEM NUMBER
- = MAINTENANCE ORDER
Reverse for assembly
- = PETROLEUM GREASE/JELLY
- = THREAD SEALANT
PTFE tape

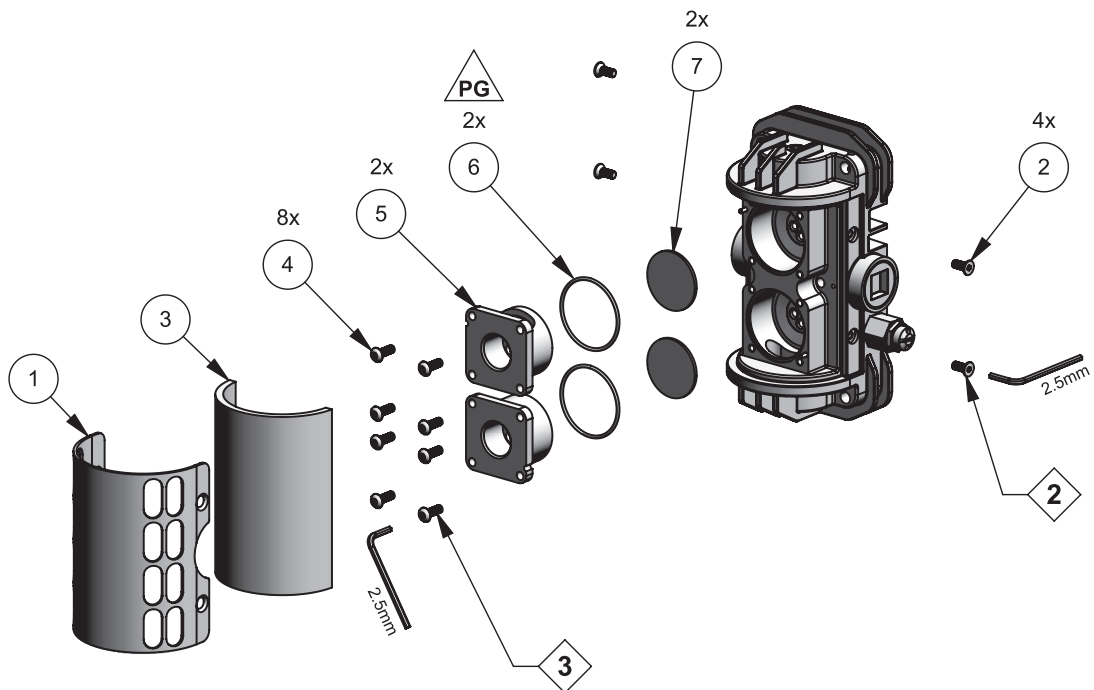

AX85SD AIR MOTOR ASSEMBLY – MAINTENANCE

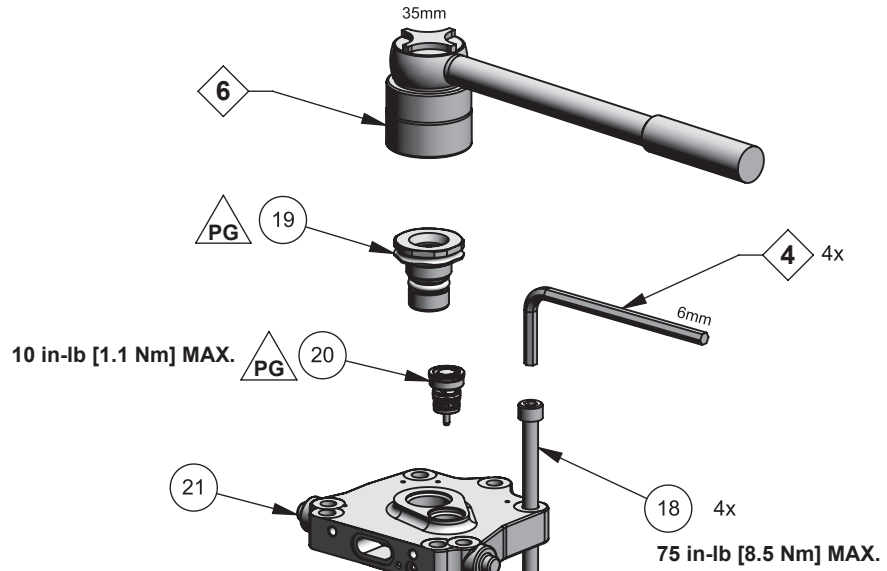

MAINTENANCE SYMBOLS:

= ITEM NUMBER

= MAINTENANCE ORDER
Reverse for assembly

PG = PETROLEUM GREASE/JELLY

TS = THREAD SEALANT
PTFE tape

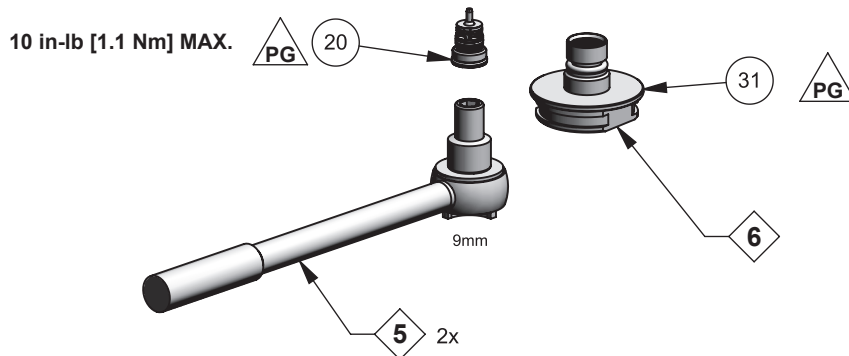
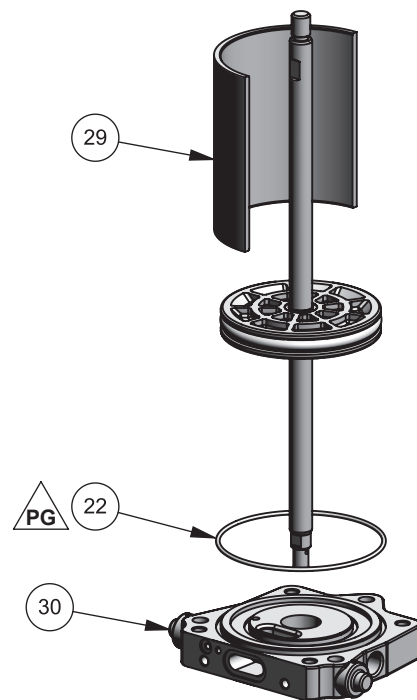

AX85SD AIR MOTOR ASSEMBLY – MAINTENANCE

⚠ DANGER



You are in the presence of magnetic fields which may interfere with the operation of certain pacemakers.

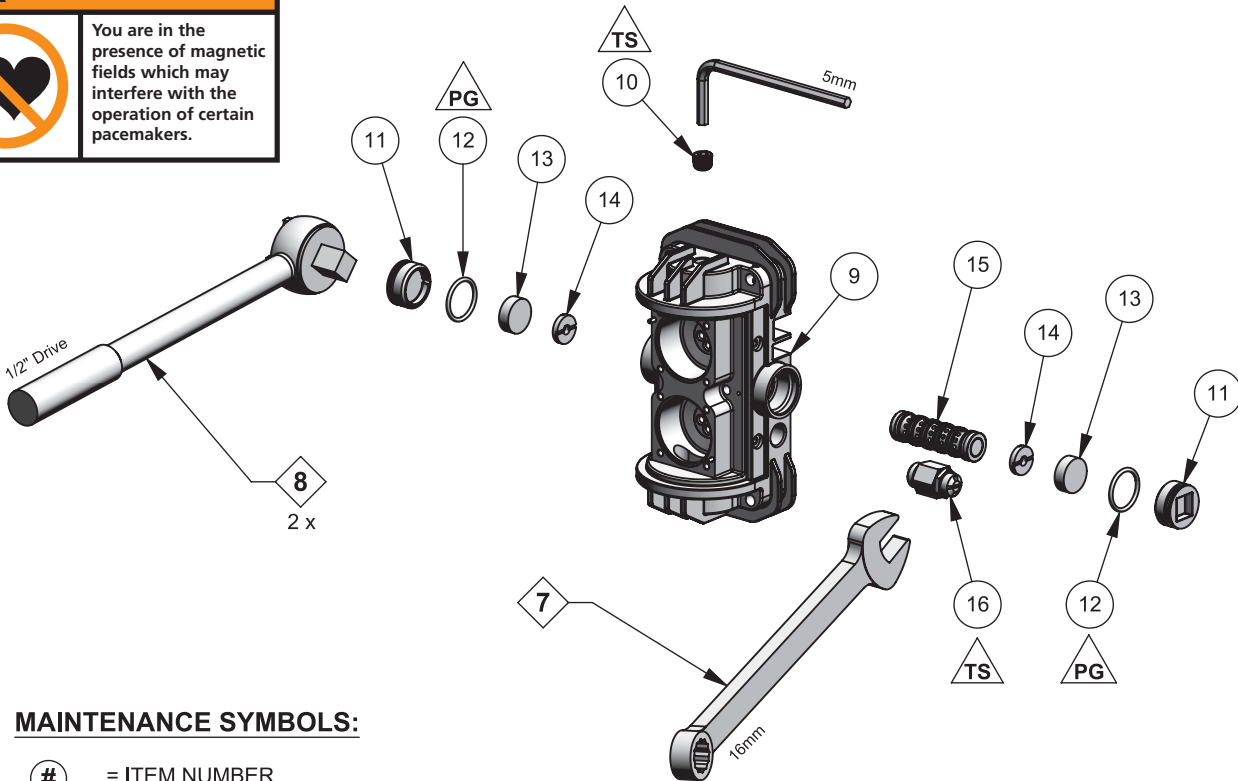

MAINTENANCE SYMBOLS:

- # = ITEM NUMBER
- # = MAINTENANCE ORDER
Reverse for assembly
- PG = PETROLEUM GREASE/JELLY
- TS = THREAD SEALANT
PTFE tape

NOTE
Spool and sleeve assembly (15) is a matched set and cannot be interchanged with other spool and sleeve assemblies.

⚠ CAUTION
Take care when handling the magnets (13). Avoid getting magnets in close proximity to each other. Injury or damage to magnets may result.

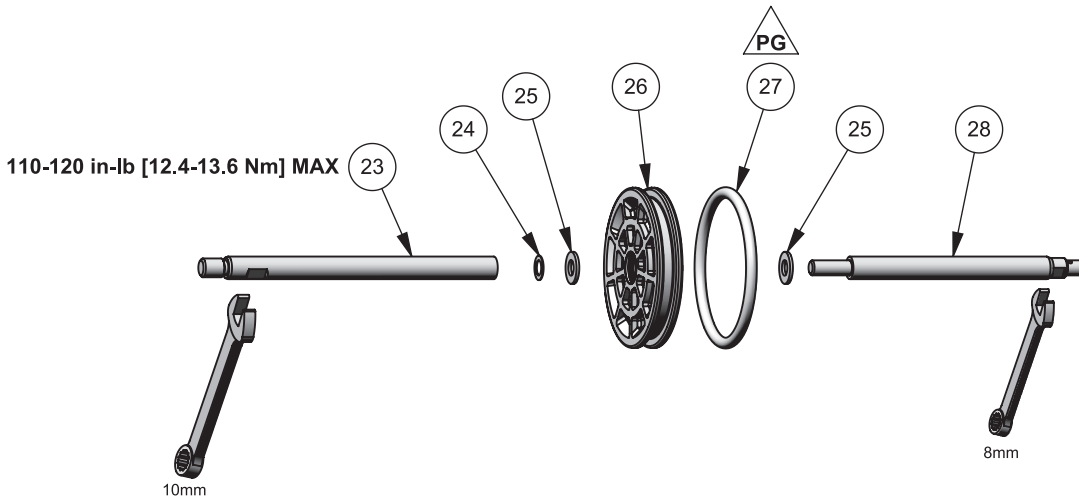

AX85SD AIR MOTOR ASSEMBLY – TROUBLESHOOTING

PROBLEM	CAUSE	SOLUTION
Pump will not start	No compressed air. System is blocked.	Check compressed air supply. Clear the blockage.
Erratic operation of air motor, air motor stops	Worn poppet assemblies. Worn or dirty spool and sleeve assembly.	Replace poppet assemblies. Clean or replace the spool and sleeve assembly as necessary.
Continuous air leak from the exhaust	Worn poppet assemblies. Worn piston seal. Worn diaphragm.	Replace poppet assemblies. Replace piston seal. Replace diaphragm.

NOTES

NOTES

NOTES

WARRANTY POLICY

This product is covered by Carlisle Fluid Technologies' materials and workmanship limited warranty. The use of any parts or accessories, from a source other than Carlisle Fluid Technologies, will void all warranties. Failure to reasonably follow any maintenance guidance provided may invalidate any warranty.

For specific warranty information please contact Carlisle Fluid Technologies.

Carlisle Fluid Technologies is a global leader in innovative finishing technologies. Carlisle Fluid Technologies reserves the right to modify equipment specifications without prior notice.

DeVilbiss®, Ransburg®, ms®, BGK®, and Binks®
are registered trademarks of Carlisle Fluid Technologies, Inc.

©2018 Carlisle Fluid Technologies, Inc.
All rights reserved.

For technical assistance or to locate an authorized distributor,
contact one of our international sales and customer support locations.

Region	Industrial / Automotive	Automotive Refinishing
Americas	Tel: 1-800-992-4657 Fax: 1-888-246-5732	Tel: 1-800-445-3988 Fax: 1-800-445-6643
Europe, Africa, Middle East, India	Tel: +44 (0)1202 571 111 Fax: +44 (0)1202 573 488	
China	Tel: +8621-3373 0108 Fax: +8621-3373 0308	
Japan	Tel: +81 45 785 6421 Fax: +81 45 785 6517	
Australia	Tel: +61 (0) 2 8525 7555 Fax: +61 (0) 2 8525 7575	

For the latest information about our products, visit www.carlisleleft.com