



MODEL 85-441 CUP REGULATOR ASSEMBLY

**FOR USE WITH BINKS MODEL 80-295 AND 80-296
2-QUART CUP ASSEMBLIES FOR REGULATING ATOMIZING AIR**

SPECIFICATIONS

Type..... Diaphragm, relieving
Outlet Size (Nipple)..... 1/4" NPS(m)
Inlet Size (Swivel Adapter)..... 1/4" NPS(f)
Gauge Port Size (2) in Regulator..... 1/8" NPT(f)
Gauge Range..... 0-60 PSIG
Rated Operating Conditions:
Inlet Pressure 300 PSIG max.
Temperature 0° to 150° F
(with dewpoint less than air temp. below 35° F)
Outlet Pressure Adjustment Range.... 2-50 PSIG*

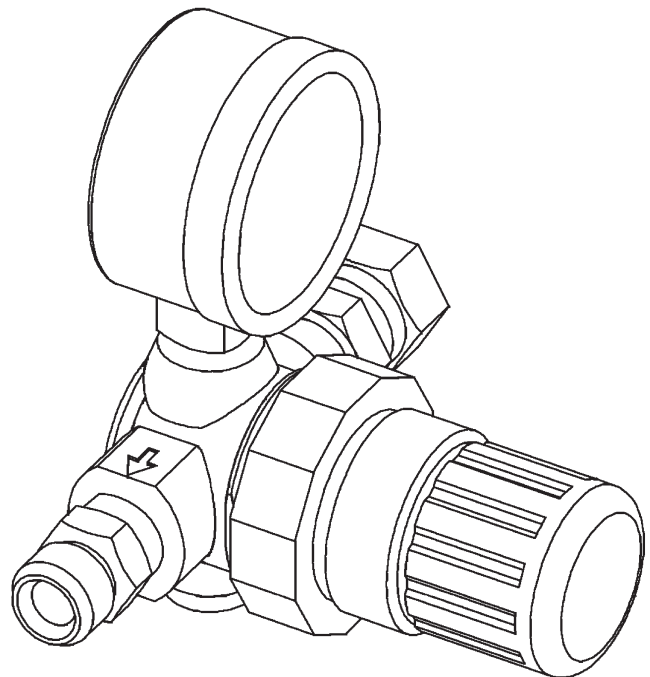

*NOTE

This range is not the minimum or maximum outlet pressure limit for this regulator. The regulator can be adjusted to zero PSIG outlet pressure and to pressures higher than 100 PSIG. However, this regulator should not be used to control pressures outside this specified range.

⚠ WARNING

IMPORTANT: READ AND FOLLOW ALL INSTRUCTIONS AND SAFETY PRECAUTIONS BEFORE INSTALLING, OPERATING OR MAINTAINING THIS EQUIPMENT. KEEP THIS MANUAL FOR FUTURE REFERENCE.



Improper use can cause bodily injury or equipment damage. Read the following:

- This air regulator and gauge assembly is intended only for use in general service **AIR SYSTEMS**. Do not use for liquids or gases other than air.
- Do not use where pressure or temperature can exceed rated operating conditions (see specifications).
- Regulated outlet pressure must never be set higher than the maximum operating pressure of the downstream air tool or equipment. An outlet pressure gauge should always be used.



The accuracy of the indication of pressure gauges can change during shipment and normal use.

If gauge accuracy is necessary for preventing risks of injury or property damage, the gauge should be checked before use and on a routine periodic basis. (See ANSI B40-1974 for gauge standards.)

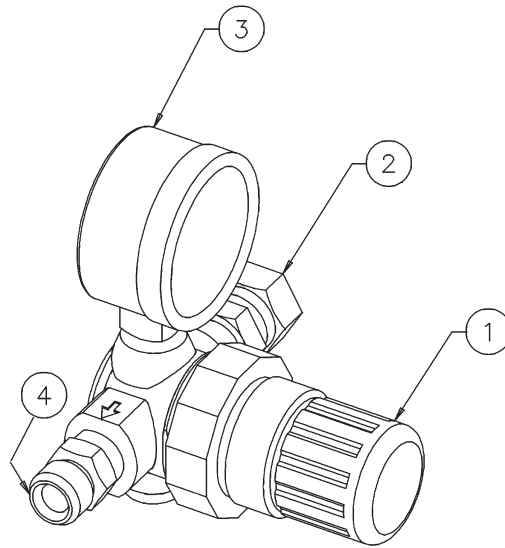

PARTS LIST

When ordering, please specify Part No.

ITEM NO.	PART NO.	DESCRIPTION	QTY.
1	■	AIR REGULATOR	1
2	SSP-8217-ZN	SWIVEL ADAPTER, 1/4 IN.	1
3	85-70	GAUGE, 60 PSI.....	1
4	H-2008	DM NIPPLE, 1/4 NPT X 1/4 NPS.....	1
	■	KK-4887-2	DIAPHRAGM REPAIR KIT..... -
		(ORDER SEPARATELY)	

INSTALLATION

Assemble the 85-441 Regulator to your Binks cup assembly as shown at right.

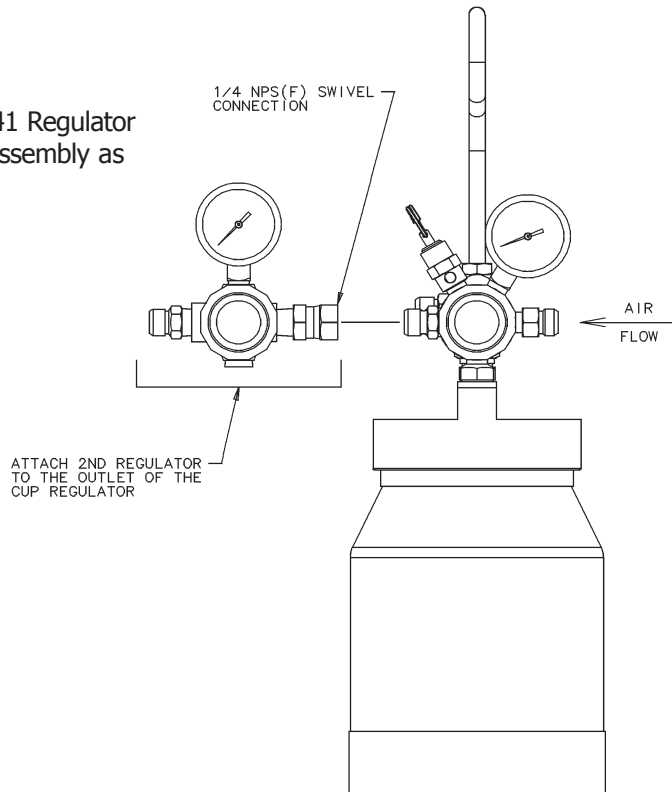

REGULATOR OPERATION, PREVENTATIVE MAINTENANCE, CLEANING & REASSEMBLY

OPERATION

1. Before turning on system air pressure, turn adjusting knob full counterclockwise. This will close regulator to produce zero air pressure. The knob is locked in position when pushed downward towards the regulator body.
2. Turn on system air pressure.
3. Turn regulator adjusting knob clockwise until desired outlet pressure is reached.
4. To avoid minor readjustment after making a change in pressure setting, always approach the desired pressure from a lower pressure. When reducing from a higher to a lower setting, first reduce to some pressure less than that desired, then bring up to the desired point. Lock the pressure setting by pushing the knob downward.

⚠ WARNING

Risk of injury from pressurized components. Turn off inlet air pressure and bleed off remaining pressure BEFORE disassembly.

PREVENTATIVE MAINTENANCE

1. Turn regulator knob counterclockwise until it stops.
2. Unscrew the bonnet from the regulator body, remove adjusting screw and nut, then the regulating spring, slip ring (1) and diaphragm (2). Using a screwdriver, unscrew the valve seat (3) and o-ring (4). Then remove valve (5) and valve spring (6).

⚠ CAUTION

Do not submerge regulator in spray gun solvents or use solvents to clean regulator parts. Damage may occur to gauge or regulator components.

CLEANING

1. Clean parts using warm water and soap.
2. Inspect all parts and replace any damaged ones.

REASSEMBLY

1. At reassembly, apply a small amount of lubricant (SSL-10 gun lube) to adjusting screw threads inside bonnet.
2. Torque valve seat (3) to 4-6 in.-lbs. (do not over-tighten). Torque bonnet to 50-60 in.-lbs.

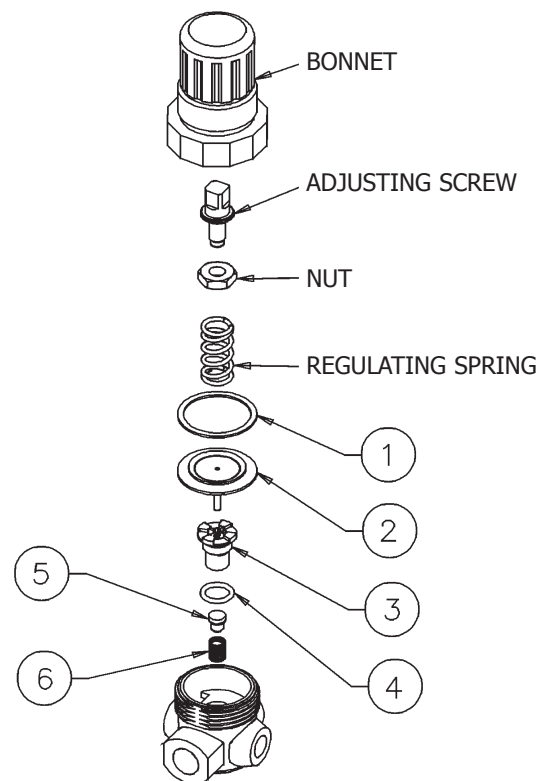

KK-4887-2 DIAPHRAGM REPAIR KIT

ITEM NO. QTY.	DESCRIPTION	
1	SLIP RING	1
2	DIAPHRAGM.....	1
3	VALVE SEAT	1
4	O-RING.....	1
5	VALVE, PTFE	1
6	VALVE SPRING	1

WARRANTY POLICY

This product is covered by Carlisle Fluid Technologies' materials and workmanship limited warranty. The use of any parts or accessories, from a source other than Carlisle Fluid Technologies, will void all warranties. Failure to reasonably follow any maintenance guidance provided may invalidate any warranty.

For specific warranty information please contact Carlisle Fluid Technologies.

For technical assistance or to locate an authorized distributor, contact one of our international sales and customer support locations.

Region	Industrial / Automotive	Automotive Refinishing
Americas	Tel: 1-800-992-4657 Fax: 1-888-246-5732	Tel: 1-800-445-3988 Fax: 1-800-445-6643
Europe, Africa, Middle East, India	Tel: +44 (0)1202 571 111 Fax: +44 (0)1202 573 488	
China	Tel: +8621-3373 0108 Fax: +8621-3373 0308	
Japan	Tel: +81 45 785 6421 Fax: +81 45 785 6517	
Australia	Tel: +61 (0) 2 8525 7555 Fax: +61 (0) 2 8525 7575	

For the latest information about our products, visit www.carlisleleft.com

Carlisle Fluid Technologies is a global leader in innovative finishing technologies. Carlisle Fluid Technologies reserves the right to modify equipment specifications without prior notice.

BGK™, Binks®, DeVilbiss®, Hosco®, MS®, and Ransburg® are all registered trademarks of Carlisle Fluid Technologies, Inc.

©2022 Carlisle Fluid Technologies, Inc.
All rights reserved.



16430 North Scottsdale Rd., Suite 450 Scottsdale, AZ 85254 USA