

BINKS MODEL 95APF AUTOMATIC AIRSPRAY GUN



AIRSPRAY GUN WITH STAINLESS STEEL FLUID INLET AND FLUID NOZZLE

MODEL 95APF SPRAY GUN

The 95APF Automatic Spray Gun is a conventional style air spray gun. Designed and fabricated from materials that may be used for pharmaceutical tablet coating applications, as well as food stuff spraying. All product contact surfaces are manufactured from FDA acceptable materials

It incorporates all stainless steel fluid inlet, fluid nozzle, and fluid needle for spraying a wide variety of solvent based and waterborne coatings. It is also pneumatically activated for application with automated spray systems. Exceptionally rugged in construction, the Binks Model 95APF is built to stand up under hard, continuous use. However, like any other fine precision instrument, its most efficient operation depends on a knowledge of its construction, operation, and maintenance.

Properly handled and cared for, it will produce beautiful, uniform atomization long after other spray guns have worn out.

- Important:**
1. Before removing any components from spray gun, shut off air and material pressure.
 2. It is recommended that this product is maintained, inspected and cleaned on regular maintenance program implemented by end user.
 3. Approval of this product in system operation is customers responsibility.

In this part sheet, the words **WARNING**, **CAUTION** and **NOTE** are used to emphasize important safety information as follows:

WARNING

Hazards or unsafe practices which could result in severe personal injury, death or substantial property damage.

CAUTION

Hazards or unsafe practices which could result in minor personal injury, product or property damage.

NOTE

Important installation, operation or maintenance information.

WARNING

Read the following warnings before using this equipment.



READ THE MANUAL

Before operating finishing equipment, read and understand all safety, operation and maintenance information provided in the operation manual.



OPERATOR TRAINING

All personnel must be trained before operating finishing equipment.



EQUIPMENT MISUSE HAZARD

Equipment misuse can cause the equipment to rupture, malfunction, or start unexpectedly and result in serious injury.



LOCK OUT / TAG-OUT

Failure to de-energize, disconnect, lock out and tag-out all power sources before performing equipment maintenance could cause serious injury or death.



AUTOMATIC EQUIPMENT

Automatic equipment may start suddenly without warning.



PRESSURE RELIEF PROCEDURE

Always follow the pressure relief procedure in the equipment instruction manual.



KEEP EQUIPMENT GUARDS IN PLACE

Do not operate the equipment if the safety devices have been removed.



KNOW WHERE AND HOW TO SHUT OFF THE EQUIPMENT IN CASE OF AN EMERGENCY



WEAR SAFETY GLASSES

Failure to wear safety glasses with side shields could result in serious eye injury or blindness.



INSPECT THE EQUIPMENT DAILY

Inspect the equipment for worn or broken parts on a daily basis. Do not operate the equipment if you are uncertain about its condition.



NEVER MODIFY THE EQUIPMENT

Do not modify the equipment unless the manufacturer provides written approval.



NOISE HAZARD

You may be injured by loud noise. Hearing protection may be required when using this equipment.

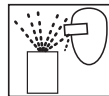

PROJECTILE HAZARD

You may be injured by venting liquids or gases that are released under pressure, or flying debris.



PINCH POINT HAZARD

Moving parts can crush and cut. Pinch points are basically any areas where there are moving parts.



STATIC CHARGE

Fluid may develop a static charge that must be dissipated through proper grounding of the equipment, objects to be sprayed and all other electrically conductive objects in the dispensing area. Improper grounding or sparks can cause a hazardous condition and result in fire, explosion or electric shock and other serious injury.



WEAR RESPIRATOR

Toxic fumes can cause serious injury or death if inhaled. Wear a respirator as recommended by the fluid and solvent manufacturer's Safety Data Sheet.



TOXIC FLUID & FUMES

Hazardous fluid or toxic fumes can cause serious injury or death if splashed in the eyes or on the skin, inhaled, injected or swallowed. LEARN and KNOW the specific hazards or the fluids you are using.



FIRE AND EXPLOSION HAZARD

Improper equipment grounding, poor ventilation, open flame or sparks can cause a hazardous condition and result in fire or explosion and serious injury.



MEDICAL ALERT

Any injury caused by high pressure liquid can be serious. If you are injured or even suspect an injury:

- Go to an emergency room immediately.
- Tell the doctor you suspect an injection injury.
- Show the doctor this medical information or the medical alert card provided with your airless spray equipment.
- Tell the doctor what kind of fluid you were spraying or dispensing.



GET IMMEDIATE MEDICAL ATTENTION

To prevent contact with the fluid, please note the following:

- Never point the gun/valve at anyone or any part of the body.
- Never put hand or fingers over the spray tip.
- Never attempt to stop or deflect fluid leaks with your hand, body, glove or rag.
- Always have the tip guard on the spray gun before spraying.
- Always ensure that the gun trigger safety operates before spraying.

IT IS THE RESPONSIBILITY OF THE EMPLOYER TO PROVIDE THIS INFORMATION TO THE OPERATOR OF THE EQUIPMENT. FOR FURTHER SAFETY INFORMATION REGARDING THIS EQUIPMENT, SEE THE GENERAL EQUIPMENT SAFETY BOOKLET (77-5300).

Binks MODEL 95APF AUTOMATIC SPRAY GUN Typical Arrangement Diagram and Hook-up for Combined Fan and Atomizing Air

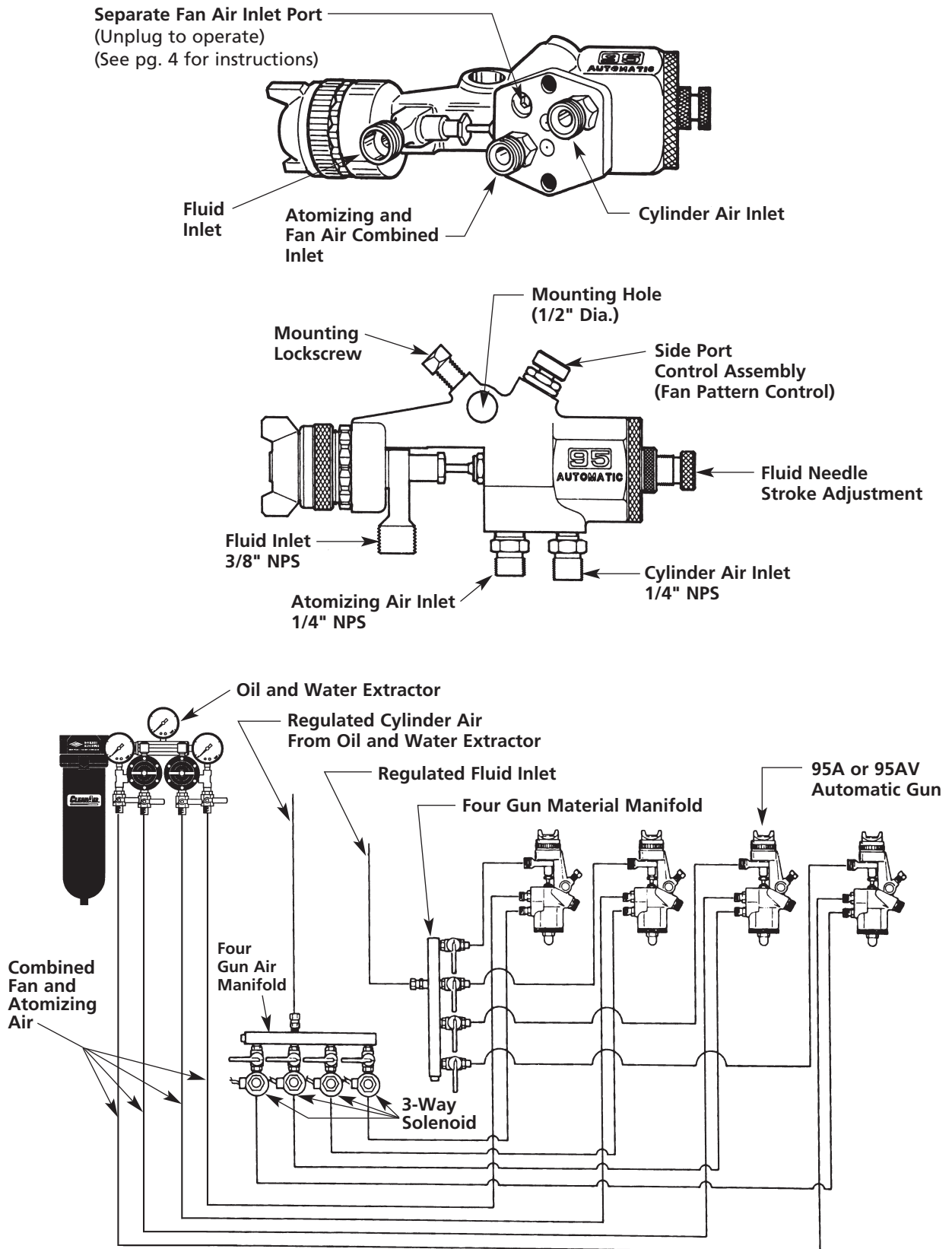

For some applications each gun may require individually regulated fluid and air inlet lines.

**Binks MODEL 95APF AUTOMATIC SPRAY GUN
Typical Arrangement Diagram and Hook-up for
Separate Fan and Atomizing Air
(See Page 5 for Internal Modifications to Gun)**

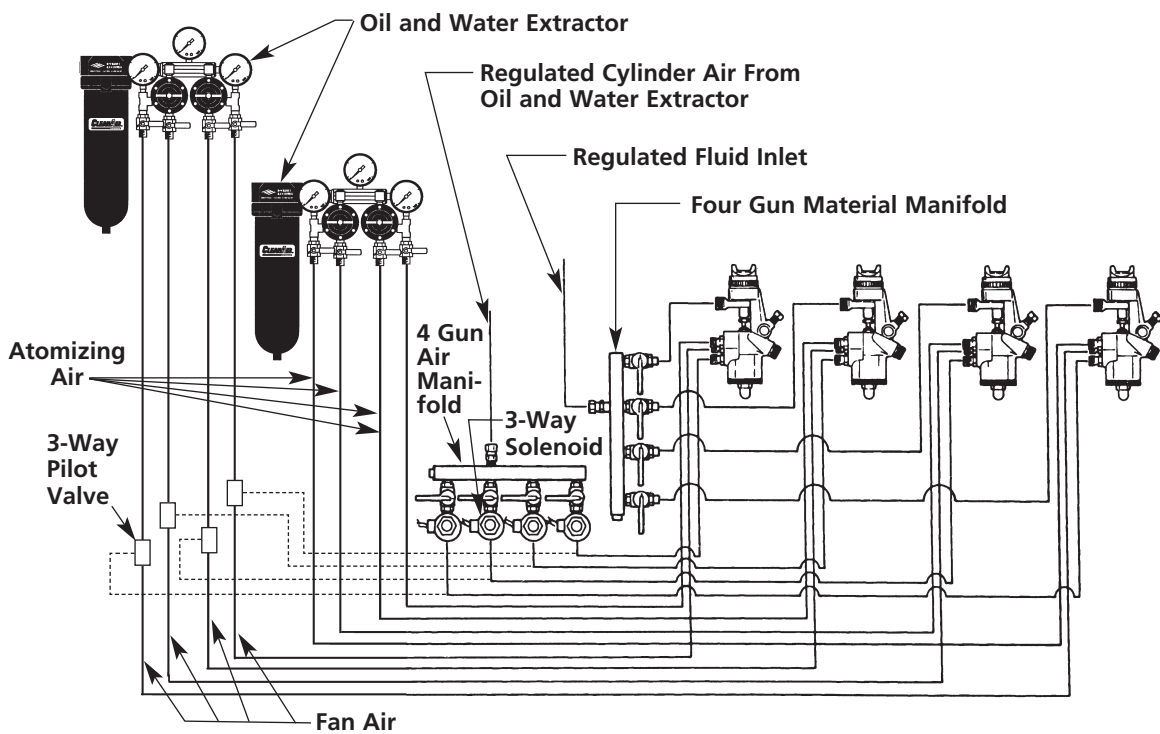
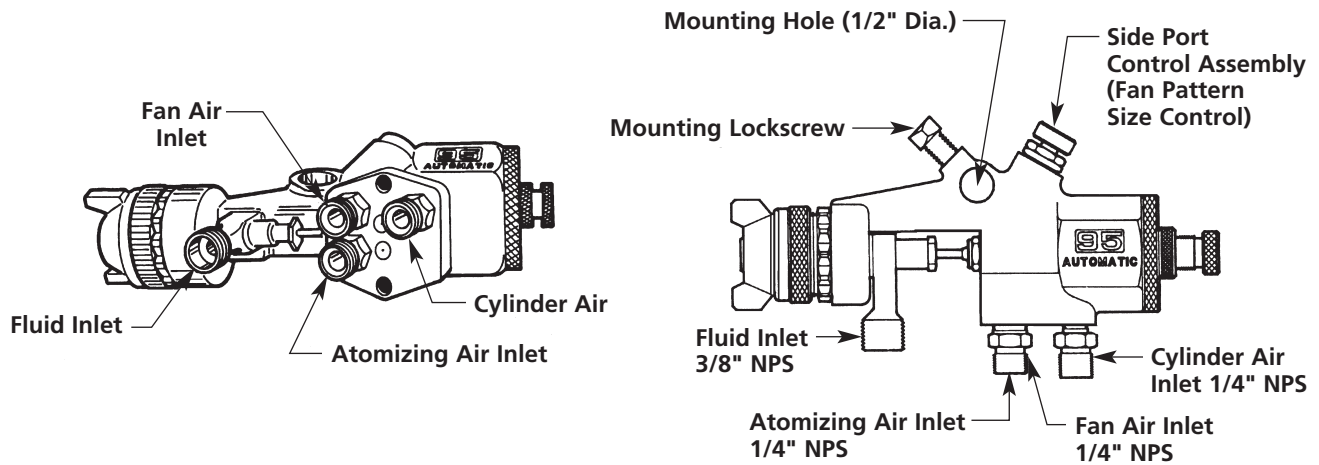

For some applications each gun may require individually regulated fluid and air inlet lines.

GENERAL NOTES

1. Have at least 55-60 P.S.I. air pressure for cylinder's operating air. (Maximum 90 PSIG)
2. To reduce overspray and obtain maximum efficiency, always spray with lowest possible fluid/air pressure that produces an acceptable spray pattern.
3. The air line from gun to 3-way valve should be as short as possible for rapid operation.
4. All air used in the gun should be dirt and moisture free. (This is accomplished by using an oil and water extractor).
5. Shut off all fluid and air lines to gun if gun is to stand idle for any length of time. (This is to prevent "build up" or accumulation of minute leaks in the system and turning on the gun).

TO CHANGE FROM COMBINED FAN AND ATOMIZING AIR TO SEPARATE FAN AND ATOMIZING AIR

1. Unscrew End Cap (28) and remove Material Needle and attached parts (22, 23, 24, 25)
(See Ass'y dwg. Pg. 7).
2. Remove Piston Ass'y (18) by injecting low pressure air Cylinder Air Port (A). **CAUTION:** Use of excessive pressure will cause piston to exit gun body at high velocity.
3. With 5/32" Allen wrench, remove Plug (20-5692) from hole (B) on inside of cylinder.
4. Insert Set Screw (20-2141) into position as shown in side cut-away. (Set screw is packaged loose.)
5. Re-install Plug (20-5692).
6. Re-install Piston, 2 Springs, Material Needle and End Cap (28). (See Ass'y dwg. Pg 7).
7. Remove Plug #20-2287 from the Fan Air Port (C).
8. Install Fitting 71-28 into Port (C). (Fitting is packaged loose.)

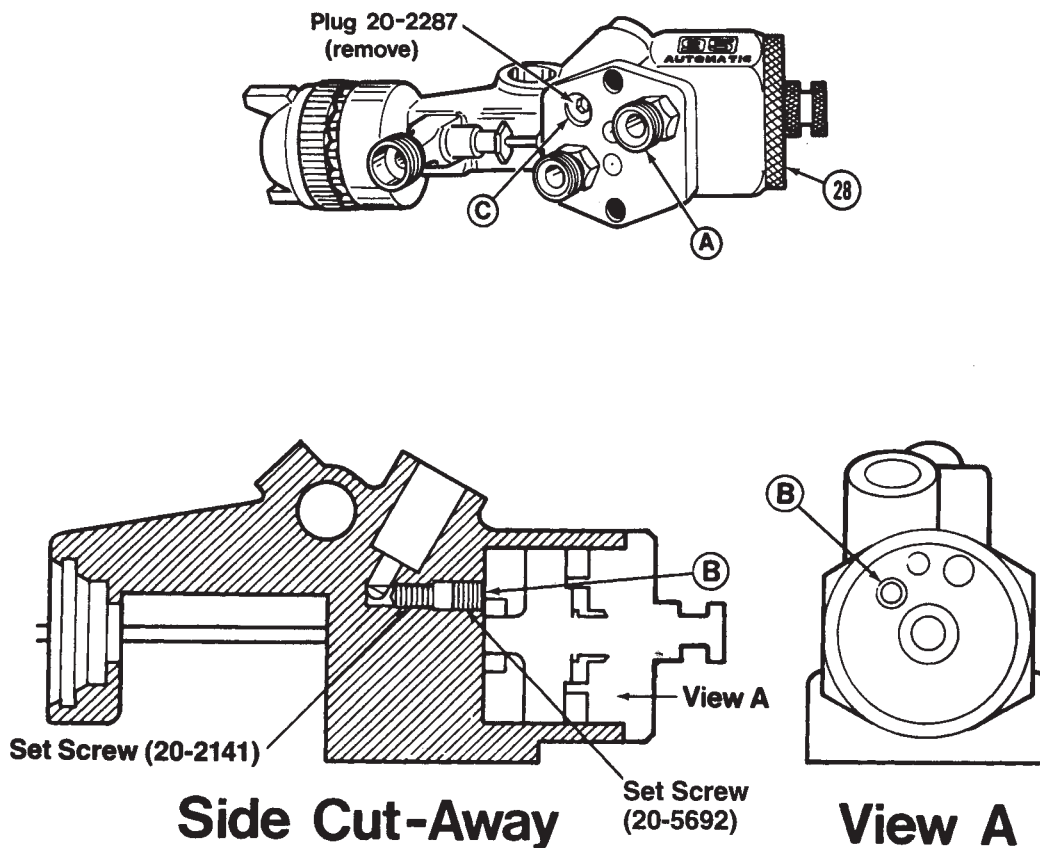

SETUP FOR SPRAYING

CONNECTING GUN TO MATERIAL HOSE

Gun should be connected by a suitable length of 3/8" diameter material hose fitted with a connector with a 3/8" NPS(f) nut at gun end. 1/4" diameter hose is recommended for use with low viscosity materials. (Fluid hoses of different composition are available for special fluids.)

CONNECTING GUN TO ATOMIZING AIR

Gun should be connected by a suitable length of 5/16" or 3/8" diameter air hose fitted with a connector and a 1/4" NPS(f) nut at gun end.

CONNECTING GUN TO CYLINDER AIR

Gun should be connected with 3/16" I.D. or 1/8" I.D. air hose of shortest length possible with 1/4" NPS(f) connector.

OPERATING THE MODEL 95 AUTOMATIC SPRAY GUN

CONTROLLING THE MATERIAL FLOW

When fed from a pressure supply, an increase in the material pressure will increase the rate of flow. Correct fluid nozzle size insures correct material flow rate. If necessary, fluid flow can also be adjusted by adjusting the amount of needle travel. This is done by loosening Lock Nut (29) and adjusting Control Knob (30) until the correct needle travel is achieved.

ADJUSTING AIR AND FLUID TIMING

A 1/16" gap between the Air Piston Ass'y (18) and Needle Body (24) should be maintained (see Fig. 1). This will create needle motion that will allow adequate air flow before the fluid starts flowing. The gap may be adjusted by partially removing the Material Needle

(22), screwing the Needle (22) either in or out of the Needle Body (24) and locking it back into the gun while being sure to check the clearance between the Air Valve Piston (18) and the Needle Body (24).

ADJUSTING THE SPRAY PATTERN

The width of the spray pattern is controlled by the Side Port Control Ass'y (7). (See Page 7). Turning this control clockwise until it is closed will give a round spray, turning it counterclockwise will widen the spray into a fan shape. The fan spray can be turned anywhere through 360° by positioning the Air Cap Ass'y (1) relative to the gun. To effect this, loosen Air Cap Ass'y, position nozzle, then, re-tighten Air Cap Ass'y.

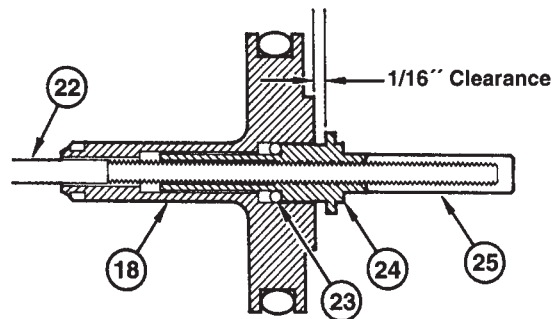

Fig. 1

NOZZLE AND NEEDLE SELECTION CHART FOR 95 APF AUTOMATIC GUN

TYPE OF FLUID AND VISCOSITY	FLUID AND AIR NOZZLES	NOZZLE TYPE	CFM AT			MAX. PATTERN	FLUID NEEDLE
			30 PSI	50 PSI	70 PSI		
VERY THIN							
14-16 SEC ZHAN 2							
(6-10 CENTIPOISE)							
DYES	62SS X 63P	PE	5.1	8.7	12.2	11.0"	763A
STAINS	63ASS X 63P	PE	5.1	8.7	12.2	11.0"	763A
WATER	63BSS X 63PB	PE	9	14.3	20	14.0"	763A
SOLVENTS	63BSS X 63PB	PE	9	14.3	20	14.0"	763A
THIN							
16-20 SEC ZHAN 2							
(10-30 CENTIPOISE)							
AQUEOUS SOLUTIONS	63ASS X 63PB	PE	9	14.3	20	14.0"	763A
WATERBORNE COATINGS	63BSS X 63PB	PE	9	14.3	20	14.0"	763A
LIGHT LUBRICANTS	63BSS X 63PB	PE	9	14.3	20	14.0"	763A
MEDIUM							
20-30 SEC ZHAN 2							
(30-70 CENTIPOISE)							
LIGHT VEGETABLE OILS	63BSS X 63PB	PE	9	14.3	20	14.0"	763A
TABLET LUBRICANTS	63BSS X 63PB	PE	9	14.3	20	14.0"	763A
EMULSIFIERS	63BSS X 63PB	PE	9	14.3	20	14.0"	763A
WAX EMULSIONS	66SS X 66SK	SE	11	15.2	19.5	13.0"	765
VEGETABLE OILS	66SS X 66SK	SE	11	15.2	19.5	13.0"	765
HEAVY							
30-40 SEC ZHAN 2							
(70-100 CENTIPOISE)							
HIGH SOLIDS	66SS X 66SK	SE	11	15.2	19.5	13.0	765
ACRYLIC LATEX	66SS X 66SD	SE	7.9	12.11		10.5	765
WATER BASE LATEX	66SS X 66SK	SE	11	15.2	19.5	13.0	765
ADHESIVES	66SS X 66SK	SE	11	15.2	19.5	13.0	765

All fluid nozzles and fluid needles are stainless steel.

Nozzle No:	59BSS	59CSS	63SS	63ASS	63BSS	63CSS	65SS	66SS	67SS	68SS
Orifice Size:	.218	.281	.028	.040	.046	.052	.059	.070	.086	.110

* Be certain your air supply is sufficient to operate nozzles selected.

PE - Pressure Feed, External
SE - Siphon Feed, External

MODEL 95APF AUTOMATIC AIRSPRAY GUN ASSEMBLY DRAWING

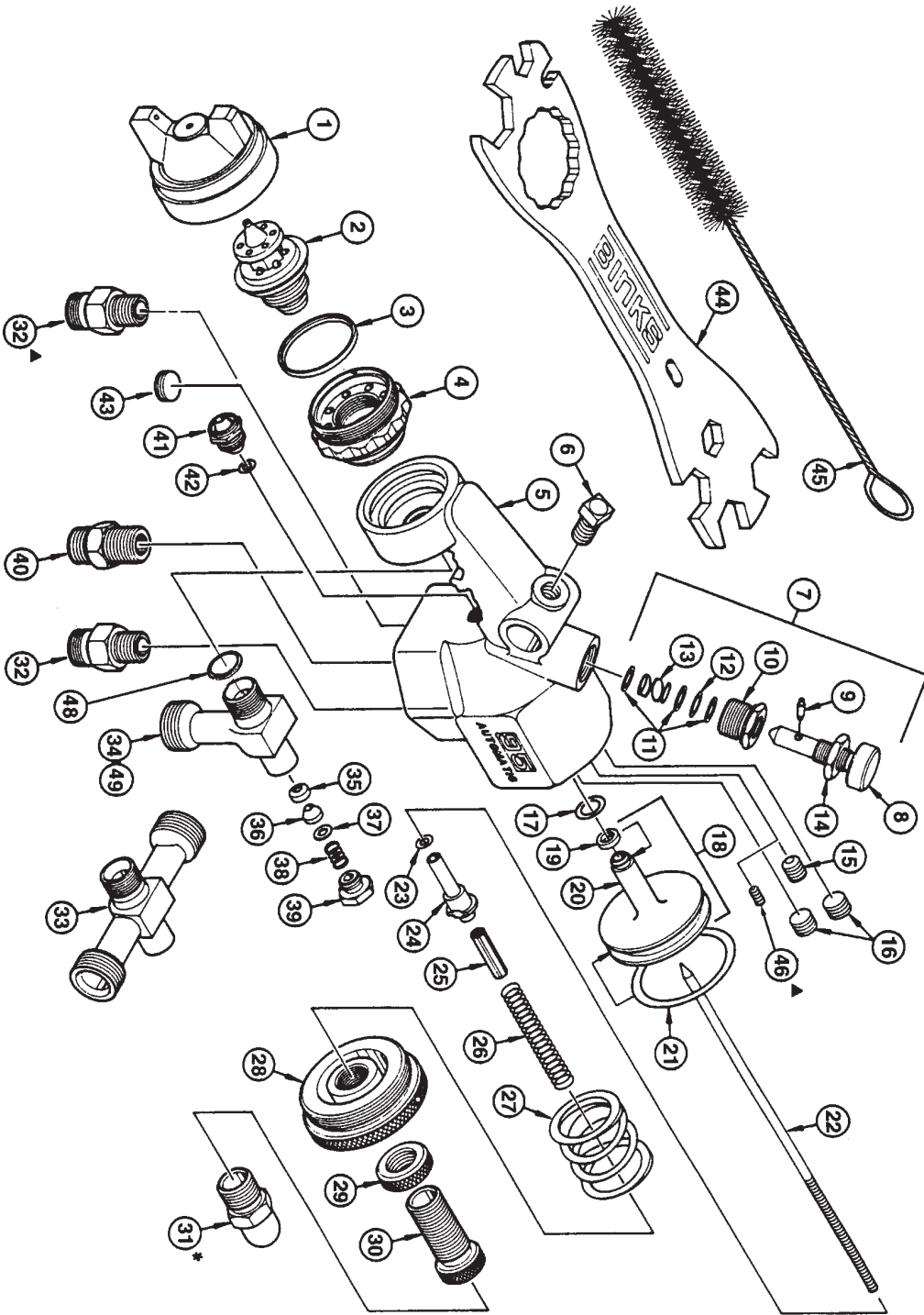

- * Item No. 31 is for installations that need to be tamper proof. It allows gun needle to fully open when triggered.
- ▲ Item No. 32 and 46 are for installations requiring separate fan and atomizing air control.
- Items 31, 32 and 46 are packaged loose.

PARTS LIST

(When ordering, please specify PART NO.)

ITEM NO.	PART NO.	DESCRIPTION	QTY.	ITEM NO.	PART NO.	DESCRIPTION	QTY.
1	★	AIR CAP ASS'Y.....	1	27	54-3707	SPRING, Piston Return.....	1
2	★	FLUID NOZZLE.....	1	28	54-3708	END CAP.....	1
3	54-918 ●	SEALING RING.....	1	29	54-3732	LOCKNUT.....	1
4	54-4416	HEAD INSERT.....	1	30	54-3731	CONTROL KNOB.....	1
5	54-4417	95 APF SERIES GUN BODY.....	1	31	54-3715	FLUID NEEDLE COVER (Optional).....	1
6	20-1359	SQ. HD. BOLT, 5/16-18 X 3/4.....	1	32	71-28	DOUBLE MALE NIPPLE, 1/8 NPT X 1/4 NPS.....	2
7	54-3720	SIDE PORT CONTROL ASS'Y.....	1	33	54-4208	FLUID INLET Recirculating (Optional).....	1
8	54-3721	CONTROL SPINDLE.....	1	34	54-4210	FLUID INLET.....	1
9	31-258	RETAINING PIN.....	1	35	54-4264 ●	GLAND ADAPTER.....	1
10	31-256	STUFFING BOX.....	1	36	54-4265 ●	NEEDLE SEAL.....	1
11	31-259	INNER WASHER.....	3	37	54-4266 ●	SEAL BACKUP.....	1
12	20-3620 ▲	O-RING.....	1	38	54-4267 ●	SPRING.....	1
13	31-241	CONTROL SPRING.....	1	39	54-4263 ●	PACKING NUT.....	1
14	54-4269	JAM NUT.....	1	40	57-13	DOUBLE MALE NIPPLE, 1/4 NPT X 1/4 NPS.....	1
15	20-5589 ■	PLUG.....	1	41	54-3716	AIR VALVE GLAND ASS'Y.....	1
16	20-5692 ■	PLUG, 1/16-20 NPT.....	2	42	20-3859 ▲	O-RING.....	1
17	20-5286 ▲	O-RING.....	1	43	20-2287 ■	PLUG, 1/8-27 NPT.....	1
18	54-3706	PISTON ASS'Y.....	1	44	54-4213	WRENCH.....	1
19	54-3729 ◆	SEAL.....	1	45	82-469	GUN BRUSH.....	1
20	54-3722 ◆	PISTON.....	1	46	20-2141	SET SCREW.....	1
21	20-4511 ▲	O-RING.....	1	47	6-428	GUNNERS MATE LUBE 2 oz. (Optional).....	1
22	★	NEEDLE.....	1	48	54-3592	INLET SEAL.....	1
23	20-3515 ▲	O-RING.....	1	49	54-4234	RESTRICTED FLUID INLET (Optional).....	1
24	54-3713	NEEDLE BODY.....	1	50	54-4270	NEEDLE COVER (Not Shown)....	1
25	54-3709	NEEDLE LOCKING NUT.....	1				
26	54-3719	SPRING, Needle Return.....	1				

- ★ See Air Cap, Fluid Nozzle, and Needle Selection Chart on Pg. 6
- Part of Repair Kit 54-4225
- ▲ Part of Repair Kit 54-3980
- Part of Gun Body Ass'y, Item 5
- ◆ Part of Item 18. Also available separately.

MAINTENANCE

LUBRICATION

Monthly: Remove Piston Ass'y (18) and lubricate the air cylinder chamber and needle valve spring with a coating of petroleum jelly. Also, lubricate Side Port Control Ass'y (7) with approved grade lubricant.

CAUTION: Never use lubricants of unapproved grade.

REMOVAL OF PISTON

To remove the piston, first unscrew the End Cap (28), remove 2 Springs (26 & 27) and pull out the Material Needle and attached parts (22, 23, 24, 25). Remove the piston by applying a few pounds of air pressure to the cylinder air inlet. This air pressure will cause the piston to pop out.

CAUTION: When removing piston, aim back of gun in a safe direction and do not use excessive air pressure.

TO REPLACE NEEDLE SEAL AND GLAND ADAPTER IN FLUID INLET

Remove End Cap (28), Springs (26 & 27) and assemble Material Needle and attached parts consisting of (22, 23, 24, 25). Proceed to the front of the gun and remove Aircap Ass'y (1) and Fluid Nozzle (2). Then, using Wrench (44), unscrew Head Insert (4) and remove

Fluid Inlet (33 or 34). Unscrew Packing Nut (39) and remove Spring (38) and Seal Backup (37). Using a No. 10 x 1 1/4" coarse thread wood screw (Binks PART NO. 20-6536) or small sheet metal screw, remove the Needle Seal (36) and Gland Adapter (35). Replace Gland Adapter (35) and Needle Seal (36). Re-insert Seal Backup (37), Spring (38) and screw on Packing Nut (39) a couple of turns so it fits loosely by hand. Reassemble Fluid Inlet (34) to Gun Body (5) with Head Insert (4). Tighten Head Insert using Wrench (44). Reassemble Fluid Nozzle (2) and Air Cap Ass'y (1). Re-insert Material Needle and attached parts (22, 23, 24, 25), Springs (26 & 27) and screw on End Cap (28). Finally, tighten Packing Nut (39) until it bottoms out on Fluid Inlet (34).

CLEANING

Generally, the gun cleaning can be accomplished with water/soap solution and a fresh water rinse cycle.

This procedure must be established by the end user.

In certain states it is now against the law to spray solvents or additives containing Volatile Organic Compounds (VOC)'s into the atmosphere when cleaning a spray gun.

In order to comply with these new air quality laws Binks recommends one of the following two methods to clean your spray finishing equipment:

1. Spray solvent through the gun into a closed system. An enclosed unit, or spray gun cleaning station, condenses solvent vapors back into liquid form which prevents escape of VOC's into the atmosphere.

2. Place spray gun in a washer type container. This system must totally enclose the spray gun, cups, nozzles, and other parts during washing, rinsing, and draining cycles. This type of unit must be able to flush solvent through the gun without releasing any VOC vapors into the atmosphere. Additionally, open containers for storage or disposal of solvent, or solvent-containing cloth or paper, used for surface preparation and clean-up may not be used. Containers shall be non-absorbent.

To clean the gun, flush the fluid lines with solvent and blow air through the air lines to make sure all the air passages are dry.

CAUTION: Never completely submerge the gun in solvent as this will dissolve the lubricating oil and dry out the seals.

TROUBLESHOOTING

FAULTY SPRAY

A faulty spray may be caused by improper cleaning, dried materials around the fluid nozzle tip or in the air cap. Soak these parts in thinners that will soften the dried material and remove with a brush or cloth. NEVER USE METAL INSTRUMENTS TO CLEAN THE AIR OR FLUID NOZZLES. THESE PARTS ARE CAREFULLY MACHINED AND ANY DAMAGE TO THEM WILL CAUSE FAULTY SPRAY. If either the Air Cap Ass'y (1) or Fluid Nozzle (2) are damaged, these parts must be replaced before perfect spray can be obtained.

INTERMITTENT SPRAY

If the spray flutters, it is caused by one of the following faults:

1. Insufficient material available. Check supply and replenish if necessary.
2. Loose Fluid Nozzle (2). Tighten, but without using undue force.
3. Leakage at Gland Adapter (35) and Needle Seal (36). Tighten Packing Nut (39) if loose, and replace Gland Adapter and Needle Seal if necessary.
4. Fluid connection insufficiently tight or dirt on cone faces of connection. Correct as necessary.
5. Leaking Cylinder Air and/or inadequate pressure.

GUN DIMENSIONS

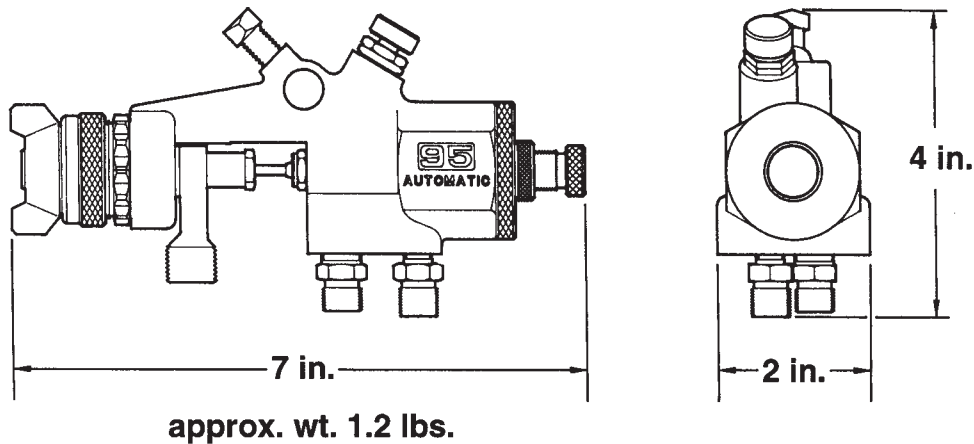

ACCESSORIES (Optional)

MOUNTING BRACKETS

Use for automatic guns. Adjustable to any position. 18" bracket arm. One inch diameter bracket clamp hole for attachment to facility hardware.

54-380 Steel Bracket for automatic guns. Shpg. wt. 5 lbs.

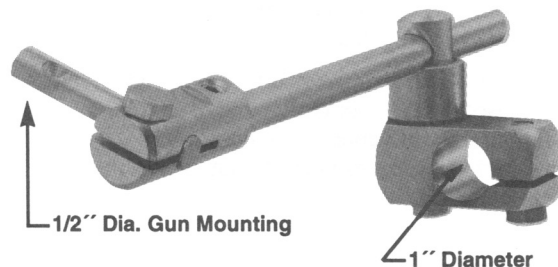

WARRANTY POLICY

This product is covered by Carlisle Fluid Technologies' materials and workmanship limited warranty. The use of any parts or accessories, from a source other than Carlisle Fluid Technologies, will void all warranties. Failure to reasonably follow any maintenance guidance provided may invalidate any warranty.

For specific warranty information please contact Carlisle Fluid Technologies.

Carlisle Fluid Technologies is a global leader in innovative finishing technologies. Carlisle Fluid Technologies reserves the right to modify equipment specifications without prior notice.

DeVilbiss®, Ransburg®, ms®, BGK®, and Binks®
are registered trademarks of Carlisle Fluid Technologies, Inc.

©2019 Carlisle Fluid Technologies, Inc.
All rights reserved.

For technical assistance or to locate an authorized distributor,
contact one of our international sales and customer support locations.

Region	Industrial / Automotive	Automotive Refinishing
Americas	Tel: 1-800-992-4657 Fax: 1-888-246-5732	Tel: 1-800-445-3988 Fax: 1-800-445-6643
Europe, Africa, Middle East, India	Tel: +44 (0)1202 571 111 Fax: +44 (0)1202 573 488	
China	Tel: +8621-3373 0108 Fax: +8621-3373 0308	
Japan	Tel: +81 45 785 6421 Fax: +81 45 785 6517	
Australia	Tel: +61 (0) 2 8525 7555 Fax: +61 (0) 2 8525 7575	

For the latest information about our products, visit www.carlisleleft.com