

## ***RCS Positive Displacement Pump Series***

### **DLC Flushable Pump Series**

**A13622-00 3.5 cc/rev**

**A13623-00 6.0 cc/rev**

**A13624-00 9.7 cc/rev**

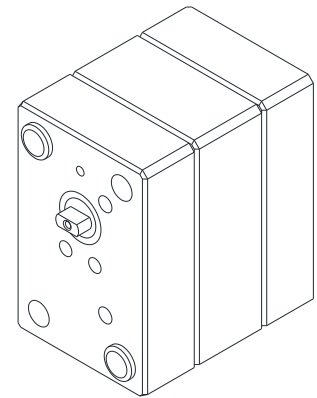

### **DLC Non-Flushable Pump Series**

**A13619-00 0.3 cc/rev**

**A13620-00 0.6 cc/rev**

**A13621-00 1.8 cc/rev**

**A13635-00 3.0 cc/rev**

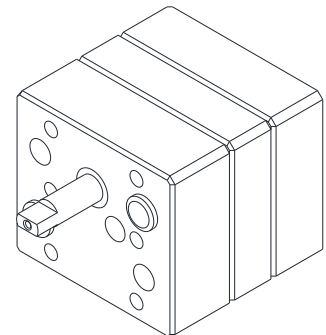

**IMPORTANT:** Before using this equipment, carefully read all **SAFETY PRECAUTIONS**, starting on page 1, and all instructions in this manual. Keep this Service Manual for future reference.

**Service Manual Price: \$50.00 (U.S.)**

**N O T E S**

---

# CONTENTS

---

	<b>PAGE</b>
<b>SAFETY:</b>	<b>1-6</b>
SAFETY PRECAUTIONS.....	1
HAZARDS / SAFEGUARDS.....	2-6
<b>INTRODUCTION:</b>	<b>7-8</b>
DESCRIPTION.....	7
FLOW RATE ACCURACY .....	7
MODEL OFFERINGS.....	7
FLUID PASSAGES .....	7
WATER-BASED APPLICATIONS.....	7
SPECIFICATIONS .....	7-8
<b>INSTALLATION:</b>	<b>9</b>
GENERAL INFORMATION .....	9
SYSTEM STARTUP.....	9
<b>OPERATION:</b>	<b>10</b>
PRINCIPLE OF OPERATION .....	10
<b>SERVICE &amp; PARTS:</b>	<b>11-16</b>
DISASSEMBLY FLUSHABLE .....	11
REASSEMBLY FLUSHABLE .....	12
PARTS LIST FLUSHABLE PUMP .....	13
DISASSEMBLY NON-FLUSHABLE .....	14
REASSEMBLY NON-FLUSHABLE .....	15
PARTS LIST NON-FLUSHABLE PUMP .....	16
<b>MAINTENANCE:</b>	<b>17</b>
CALIBRATION .....	17
TROUBLESHOOTING .....	17
SERVICING .....	17
<b>APPENDICIES:</b>	<b>18-20</b>
APPENDIX A— INSTALLATION OF SHAFT SEALS .....	18
<b>WARRANTY POLICIES:</b>	<b>21</b>
LIMITED APPLIED WARRANTY .....	21

# SAFETY

## SAFETY PRECAUTIONS

Before operating, maintaining or servicing any Ransburg electrostatic coating system, read and understand all of the technical and safety literature for your Ransburg products. This manual contains information that is important for you to know and understand. This information relates to **USER SAFETY** and **PREVENTING EQUIPMENT PROBLEMS**. To help you recognize this information, we use the following symbols. Please pay particular attention to these sections.

**A WARNING!** states information to alert you to a situation that might cause serious injury if instructions are not followed.

**A CAUTION!** states information that tells how to prevent damage to equipment or how to avoid a situation that might cause minor injury.

**A NOTE** is information relevant to the procedure in progress.

While this manual lists standard specifications and service procedures, some minor deviations may be found between this literature and your equipment. Differences in local codes and plant requirements, material delivery requirements, etc., make such variations inevitable. Compare this manual with your system installation drawings and appropriate Ransburg equipment manuals to reconcile such differences.

Careful study and continued use of this manual will provide a better understanding of the equipment and process, resulting in more efficient operation, longer trouble-free service and faster, easier troubleshooting. If you do not have the manuals and safety literature for your Ransburg system, contact your local Ransburg representative or Ransburg.



### WARNING

► The user **MUST** read and be familiar with the Safety Section in this manual and the Ransburg safety literature therein identified.



► This manual **MUST** be read and thoroughly understood by **ALL** personnel who operate, clean or maintain this equipment! Special care should be taken to ensure that the **WARNINGS** and safety requirements for operating and servicing the equipment are followed. The user should be aware of and adhere to **ALL** local building and fire codes and ordinances as well as **NFPA-33 SAFETY STANDARD, LATEST EDITION**, prior to installing, operating, and/or servicing this equipment.





### WARNING

► The hazards shown on the following pages may occur during the normal use of this equipment. Please read the hazard chart beginning on page 2.

<b>AREA</b> Tells where hazards may occur.	<b>HAZARD</b> Tells what the hazard is.	<b>SAFEGUARDS</b> Tells how to avoid the hazard.
<p><b>Spray Area</b></p> 	<p><b>Fire Hazard</b></p> <p>Improper or inadequate operation and maintenance procedures will cause a fire hazard.</p> <p>Protection against inadvertent arcing that is capable of causing fire or explosion is lost if any safety interlocks are disabled during operation. Frequent Power Supply or Controller shut-down indicates a problem in the system requiring correction.</p>	<p>Fire extinguishing equipment must be present in the spray area and tested periodically.</p> <p>Spray areas must be kept clean to prevent the accumulation of combustible residues.</p> <p>Smoking must never be allowed in the spray area.</p> <p>The high voltage supplied to the atomizer must be turned off prior to cleaning, flushing or maintenance.</p> <p>When using solvents for cleaning:</p> <ul style="list-style-type: none"> <li>• Those used for equipment flushing should have flash points equal to or higher than those of the coating material.</li> <li>• Those solvents used for general cleaning must have a flash point at minimum of 5°C (9°F) greater than the ambient temperature. It is the end users responsibility to insure this condition is met.</li> <li>• Spray booth ventilation must be kept at the rates required by NFPA-33, OSHA, country, and local codes. In addition, ventilation must be maintained during cleaning operations using flammable or combustible solvents.</li> </ul> <p>Electrostatic arcing must be prevented. Safe sparking distance must be maintained between the parts being coated and the applicator. A distance of 1 inch for every 10KV of output voltage is required at all times.</p> <p>Test only in areas free of combustible material.</p> <p>Testing may require high voltage to be on, but only as instructed.</p> <p>Non-factory replacement parts or unauthorized equipment modifications may cause fire or injury.</p> <p>If used, the key switch bypass is intended for use only during setup operations. Production should never be done with safety interlocks disabled.</p> <p>Never use equipment intended for use in waterborne installations to spray solvent based materials.</p> <p>The paint process and equipment should be set up and operated in accordance with NFPA-33, NEC, OSHA, local, country, and European Health and Safety Norms.</p>

<p><b>AREA</b></p> <p>Tells where hazards may occur.</p>	<p><b>HAZARD</b></p> <p>Tells what the hazard is.</p>	<p><b>SAFEGUARDS</b></p> <p>Tells how to avoid the hazard.</p>
<p><b>Spray Area</b></p> 	<p><b>Explosion Hazard</b></p> <p>Improper or inadequate operation and maintenance procedures will cause a fire hazard.</p> <p>Protection against inadvertent arcing that is capable of causing fire or explosion is lost if any safety interlocks are disabled during operation.</p> <p>Frequent Power Supply or Controller shutdown indicates a problem in the system requiring correction.</p>	<p>Electrostatic arcing must be prevented. Safe sparking distance must be maintained between the parts being coated and the applicator. A distance of 1 inch for every 10KV of output voltage is required at all times.</p> <p>Unless specifically approved for use in hazardous locations, all electrical equipment must be located <b>outside</b> Class I or II, Division 1 or 2 hazardous areas, in accordance with NFPA-33.</p> <p>Test only in areas free of flammable or combustible materials.</p> <p>The current overload sensitivity (if equipped) <b>MUST</b> be set as described in the corresponding section of the equipment manual. Protection against inadvertent arcing that is capable of causing fire or explosion is lost if the current overload sensitivity is not properly set. Frequent power supply shutdown indicates a problem in the system which requires correction.</p> <p>Always turn the control panel power off prior to flushing, cleaning, or working on spray system equipment.</p> <p>Before turning high voltage on, make sure no objects are within the safe sparking distance.</p> <p>Ensure that the control panel is interlocked with the ventilation system and conveyor in accordance with NFPA-33, EN 50176.</p> <p>Have fire extinguishing equipment readily available and tested periodically.</p>
<p><b>General Use and Maintenance</b></p> 	<p>Improper operation or maintenance may create a hazard.</p> <p>Personnel must be properly trained in the use of this equipment.</p>	<p>Personnel must be given training in accordance with the requirements of NFPA-33, EN 60079-0.</p> <p>Instructions and safety precautions must be read and understood prior to using this equipment.</p> <p>Comply with appropriate local, state, and national codes governing ventilation, fire protection, operation maintenance, and housekeeping. Reference OSHA, NFPA-33, EN Norms and your insurance company requirements.</p>

<b>AREA</b> Tells where hazards may occur.	<b>HAZARD</b> Tells what the hazard is.	<b>SAFEGUARDS</b> Tells how to avoid the hazard.
<p><b>Spray Area / High Voltage Equipment</b></p> 	<p><b>Electrical Discharge</b></p> <p>There is a high voltage device that can induce an electrical charge on ungrounded objects which is capable of igniting coating materials.</p> <p>Inadequate grounding will cause a spark hazard. A spark can ignite many coating materials and cause a fire or explosion.</p>	<p>Parts being sprayed and operators in the spray area must be properly grounded.</p> <p>Parts being sprayed must be supported on conveyors or hangers that are properly grounded. The resistance between the part and earth ground must not exceed 1 meg ohm. (Refer to NFPA-33.)</p> <p>Operators must be grounded. Rubber soled insulating shoes should not be worn. Grounding straps on wrists or legs may be used to assure adequate ground contact.</p> <p>Operators must not be wearing or carrying any ungrounded metal objects.</p> <p>When using an electrostatic handgun, operators must assure contact with the handle of the applicator via conductive gloves or gloves with the palm section cut out.</p> <p><b>NOTE: REFER TO NFPA-33 OR SPECIFIC COUNTRY SAFETY CODES REGARDING PROPER OPERATOR GROUNDING.</b></p> <p>All electrically conductive objects in the spray area, with the exception of those objects required by the process to be at high voltage, must be grounded. Grounded conductive flooring must be provided in the spray area.</p> <p>Always turn off the power supply prior to flushing, cleaning, or working on spray system equipment.</p> <p>Unless specifically approved for use in hazardous locations, all electrical equipment must be located <b>outside</b> Class I or II, Division 1 or 2 hazardous areas, in accordance with NFPA-33.</p>

<b>AREA</b> Tells where hazards may occur.	<b>HAZARD</b> Tells what the hazard is.	<b>SAFEGUARDS</b> Tells how to avoid the hazard.
<p><b>Electrical Equipment</b></p> 	<p><b>Electrical Discharge</b></p> <p>High voltage equipment is utilized in the process. Arcing in the vicinity of flammable or combustible materials may occur. Personnel are exposed to high voltage during operation and maintenance.</p> <p>Protection against inadvertent arcing that may cause a fire or explosion is lost if safety circuits are disabled during operation.</p> <p>Frequent power supply shutdown indicates a problem in the system which requires correction.</p> <p>An electrical arc can ignite coating materials and cause a fire or explosion.</p>	<p>Unless specifically approved for use in hazardous locations, the power supply, control cabinet, and all other electrical equipment must be located outside Class I or II, Division 1 and 2 hazardous areas in accordance with NFPA-33 and EN 50176.</p> <p>Turn the power supply OFF before working on the equipment.</p> <p>Test only in areas free of flammable or combustible material.</p> <p>Testing may require high voltage to be on, but only as instructed.</p> <p>Production should never be done with the safety circuits disabled.</p> <p>Before turning the high voltage on, make sure no objects are within the sparking distance.</p>
<p><b>Toxic Substances</b></p> 	<p><b>Chemical Hazard</b></p> <p>Certain materials may be harmful if inhaled, or if there is contact with the skin.</p>	<p>Follow the requirements of the Material Safety Data Sheet supplied by coating material manufacturer.</p> <p>Adequate exhaust must be provided to keep the air free of accumulations of toxic materials.</p> <p>Use a mask or respirator whenever there is a chance of inhaling sprayed materials. The mask must be compatible with the material being sprayed and its concentration. Equipment must be as prescribed by an industrial hygienist or safety expert, and be NIOSH approved.</p>



<b>AREA</b> Tells where hazards may occur.	<b>HAZARD</b> Tells what the hazard is.	<b>SAFEGUARDS</b> Tells how to avoid the hazard.
<p><b>Spray Area</b></p> 	<p><b>Explosion Hazard— Incompatible Materials</b></p> <p>Halogenated hydrocarbon solvents for example: methylene chloride and 1,1,1, Trichloroethane are not chemically compatible with the aluminum that might be used in many system components. The chemical reaction caused by these solvents reacting with aluminum can become violent and lead to an equipment explosion.</p>	<p>Aluminum is widely used in other spray application equipment - such as material pumps, regulators, triggering valves, etc. Halogenated hydrocarbon solvents must never be used with aluminum equipment during spraying, flushing, or cleaning. Read the label or data sheet for the material you intend to spray. If in doubt as to whether or not a coating or cleaning material is compatible, contact your coating supplier. Any other type of solvent may be used with aluminum equipment.</p>

# INTRODUCTION

## GENERAL DESCRIPTION

These positive displacement pumps have been developed for precise metering for use in RCS and RCS-2 systems.

## FLOW RATE ACCURACY

Flow rate accuracies of  $\pm 5\%$  can be expected with use of these positive displacement pumps.

## CURRENT MODELS OFFERED

### Flushable Version:

A13622-00 3.5 cc/rev  
A13623-00 6.0 cc/rev  
A13624-00 9.7 cc/rev

### Non-Flushable Version:

A13619-00 0.3 cc/rev  
A13620-00 0.6 cc/rev  
A13621-00 1.8 cc/rev  
A13635-00 3.0 cc/rev

## FLUID PASSAGES

Both pump versions employ a DLC (Diamond Like Coating) for extended wear. The flushable pump series (when equipped with a 22-337 by-pass valve) provides faster color changes and minimizes solvent usage.

## WATER-BASED APPLICATIONS

The DLC pumps can be used in waterborne applications overall. It is highly recommended that water-based materials be submitted to our lab for evaluation to determine material compatibility with these pumps.

## SPECIFICATIONS

<b>Flow Rate:</b>	See Pump Table 1
<b>Accuracy:</b>	95% Efficiency based on testing with Wet-Sol Material @ 50 RPM with 1 bar differential on Pump Inlet / Outlet. (System Dependent )
<b>Working Pressure:</b>	See Pump Table 1
<b>Temperature:</b>	See Pump Table 1
<b>Materials:</b>	
<b>Body:</b>	See Pump Table 1
<b>Gears:</b>	See Pump Table 1
<b>Bushings:</b>	See Pump Table 1
<b>Shafts:</b>	See Pump Table 1
<b>Seal:</b>	22-315 (Flushable) 22-383 (Non-Flushable)
<b>Filtration:</b>	100 Mesh (maximum)
<b>Connections:</b>	22-935-1 Color (Flushable Manifold)  22-872 Catalyst (Non-Flushable Manifolds)
<b>Weight:</b>	See Pump Table 1

# INTRODUCTION

## RCS GEAR PUMP TABLE 1 - SPECIFICATIONS -

Part No.	A13619	A13620	A13621	A13635	A13622	A13623	A13624
Displacement (cc/rev)	0.3	0.6	1.8	3.0	3.5	6.0	9.7
Weight of Pump (lbs.)	3.6	3.8	3.8	4.4	6.4	6.6	8.2
Base Pump Material	440B	440B	440B	440B	440B	440B	440B
Pump Bushing Material	440B	440B	440B	440B	440B	440B	440B
Shaft & Gear Material	440B	440B	440B	440B	440B	440B	440B
Hardness DLC (Vickers)	2500	2500	2500	2500	2500	2500	2500
Working Pressure max (PSI)	300	300	300	300	300	300	300
Input pressure max (PSI)	145	145	145	145	145	145	145
Working temp. (°C)	-20 to 150°	-20 to 150°	-20 to 150°	-20 to 150°	-20 to 150°	-20 to 150°	-20 to 150°
Pump Style	Non-Flushable (Catalyst)	Non-Flushable (Catalyst)	Non-Flushable (Catalyst)	Non-Flushable (Catalyst)	Flushable (Resin)	Flushable (Resin)	Flushable (Resin)

# INSTALLATION

## GENERAL INFORMATION

The displacement pump (Gear Pump) is used on the RCS and RCS-2 systems. Pumps are mounting directly to either a resin manifold (for the flushable pump unit) or a catalyst manifold (for the non-flushable pump). Typical torque applied to the mounting bolts should not exceed 17 lb-ft (23 N-m). Excessive torque can lead to pump seizure and internal pump damage. Always follow specified torque settings.

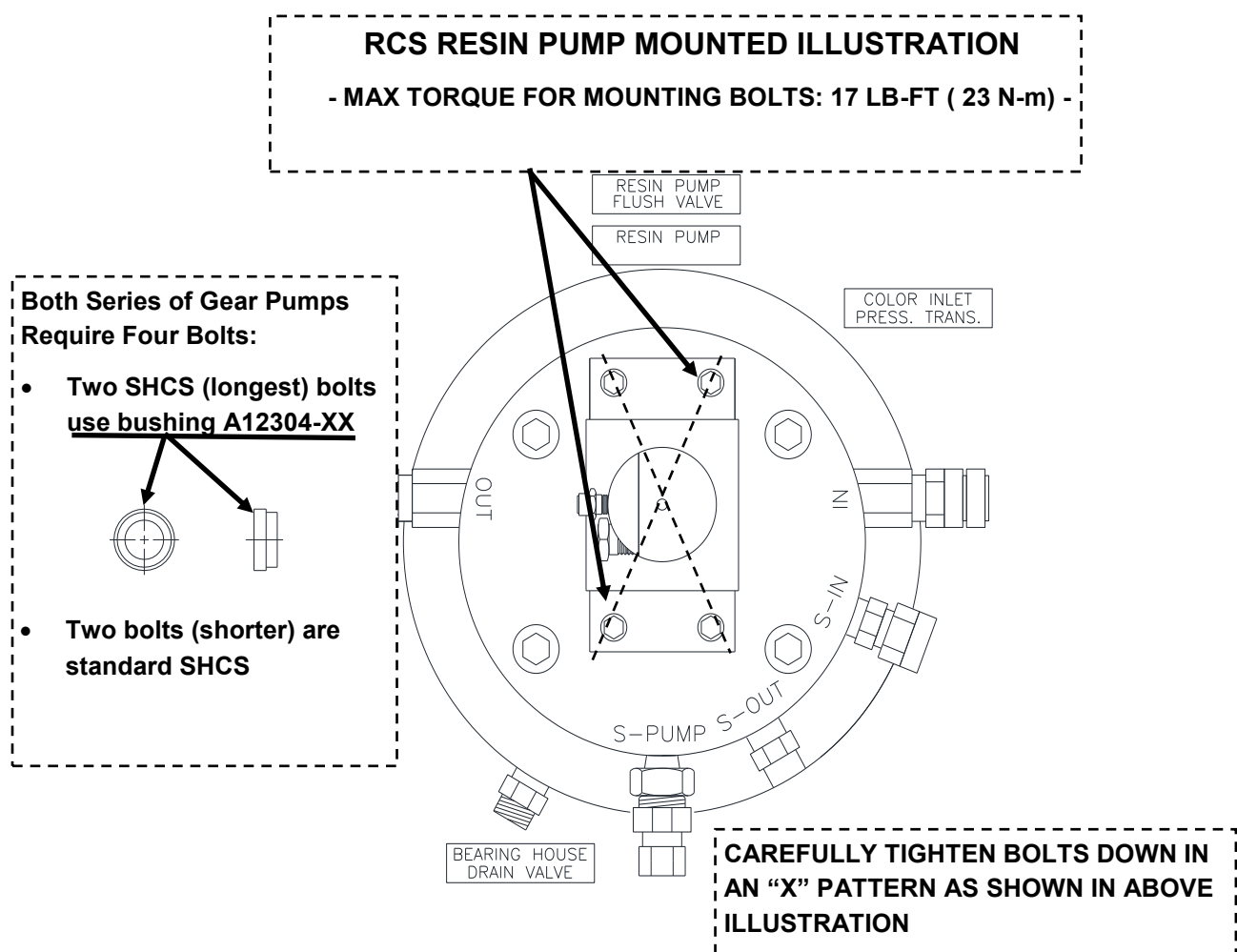

### Note:

**TORQUE REQUIREMENTS AND TIGHTENING PROCEDURES HAVE THE SAME TORQUE SPECIFICATIONS FOR BOTH CATALYST (NON-FLUSHABLE) AND RESIN (FLUSHABLE) PUMPS.**

### System Start-Up

Pump assemblies are shipped with Wet-sol material to protect pump inner workings. To remove Wet-sol, flush and purge the system with solvent as needed.

---

# OPERATION

---

## PRINCIPLE OF OPERATION

The external gear pump is a positive displacement (PD) type of pump generally used for the transfer and metering of liquids. The gear pump is a precision machine with extremely tight fits and tolerances, and is capable of working under high differential pressures.

Typically there is a drive gear driven by a motor that rotates an idler gear in the opposite direction. When the gears rotate, the liquid, which is trapped in the gear teeth spaces between the housing bore and the outside of the gears, is transferred from the inlet side of the pump to the outlet side. The pumped liquid moves around the outside of the gears and not between the gears. The rotating gears continue to deliver a fresh supply of liquid from the suction (inlet) side of the pump to the discharge (outlet) side of the pump, with virtually no pulsations. The meshing of the gears on the discharge side of the pump forces the liquid out of the pump and into the discharge port.

Flow rate through the pump is controlled simply by varying the RPM of the motor driving the pump. On RCS and RCS-2 Systems, it is recommended that the RPM of the pump not be allowed to exceed 150 RPM's.

The accuracy of the gear pump is directly affected by both the viscosity of the material being pumped and the differential pressure across the pump.

If the material is too thin (e.g. viscosities less than 30 centipoise), it will not be properly metered by the pump and inaccurate flow rates will result.

If the inlet pressure of the pump is too low, the pump will be starved for material and will cavitate, resulting in lower flows than expected. Additionally, if the outbound pressure is significantly higher than the inlet pressure, the gears will slip by the material, also causing the flow to be less than expected.

On the other hand, if the inlet pressure is too high (especially at low viscosities), material can "blow by" the gears in the meter and the resultant flow will be higher than expected.

Positive displacement gear pumps are most accurate when the pressure across the pump (known as differential pressure) is minimized. That is, if the inlet pressure can be maintained at a pressure that is very close to the outlet pressure, the most accuracy will be realized. The RCS and RCS-2 Systems have the ability to control the inlet pressure automatically based on the value of the outlet pressure. This, however, is an optional feature. If you are interested in enabling this feature on your RCS or RCS-2 System, contact your Ransburg representative.

## DLC COATED FLUSHABLE PUMP

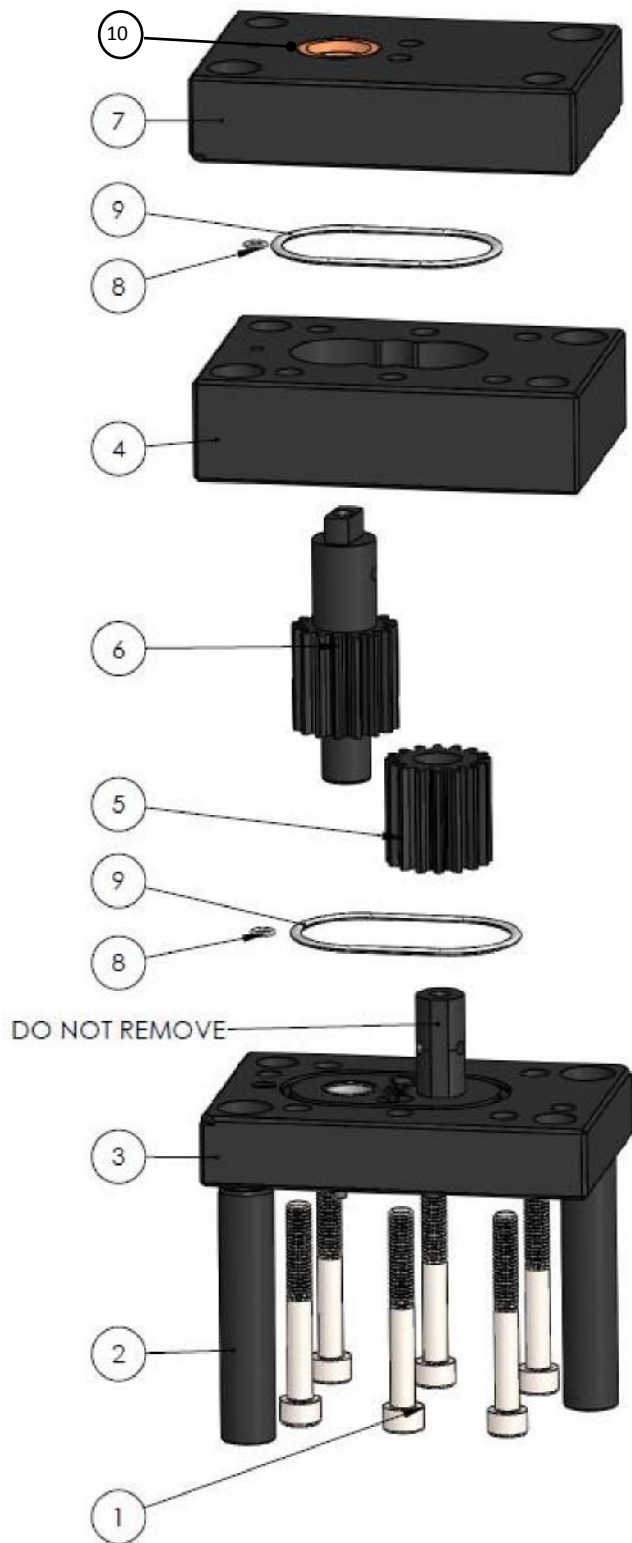

FIGURE 1-3 EXPLODED PUMP VIEW

### MODELS COVERED:

A13622-00 3.5 cc/rev

A13623-00 6.0 cc/rev

A13624-00 9.7 cc/rev

### PUMP DISASSEMBLY

1. Carefully press out the alignment pins (#2).
2. Unscrew the M6 bolts (#1) from the bottom of the pump.
3. Remove the top plate (#7), carefully.
4. Remove the center plate (#4) carefully.
5. Remove the drive shaft with gear (#6) & idler gear (#5).
6. To remove gear from shaft, remove circlips and slide gear off of shaft.
7. Pull seal (#10) from front plate (use seal puller or drive from opposite side). Be careful not to damage the pump bore during removal.

**Please Note:** Driven shaft is fixed in the body and cannot be removed. **(DO NOT ATTEMPT TO REMOVE THE FIXED SHAFT!)**

### PUMP CLEANING PROCESS

1. All parts should be cleaned with a suitable cleaning agent. **(CLEANING WITH ABRASIVE MATERIALS WILL DAMAGE THE PUMP AND VOID WARRANTY!)**
2. Discard used O-rings (#10) and replace with new ones during reassembly.
3. Pump plates should be dried with lint free towel and lubricated before reassembly with wet-sol or equivalent material.

**DLC COATED FLUSHABLE PUMP—Cont'd**

**FIGURE 1-4 EXPLODED PUMP VIEW**

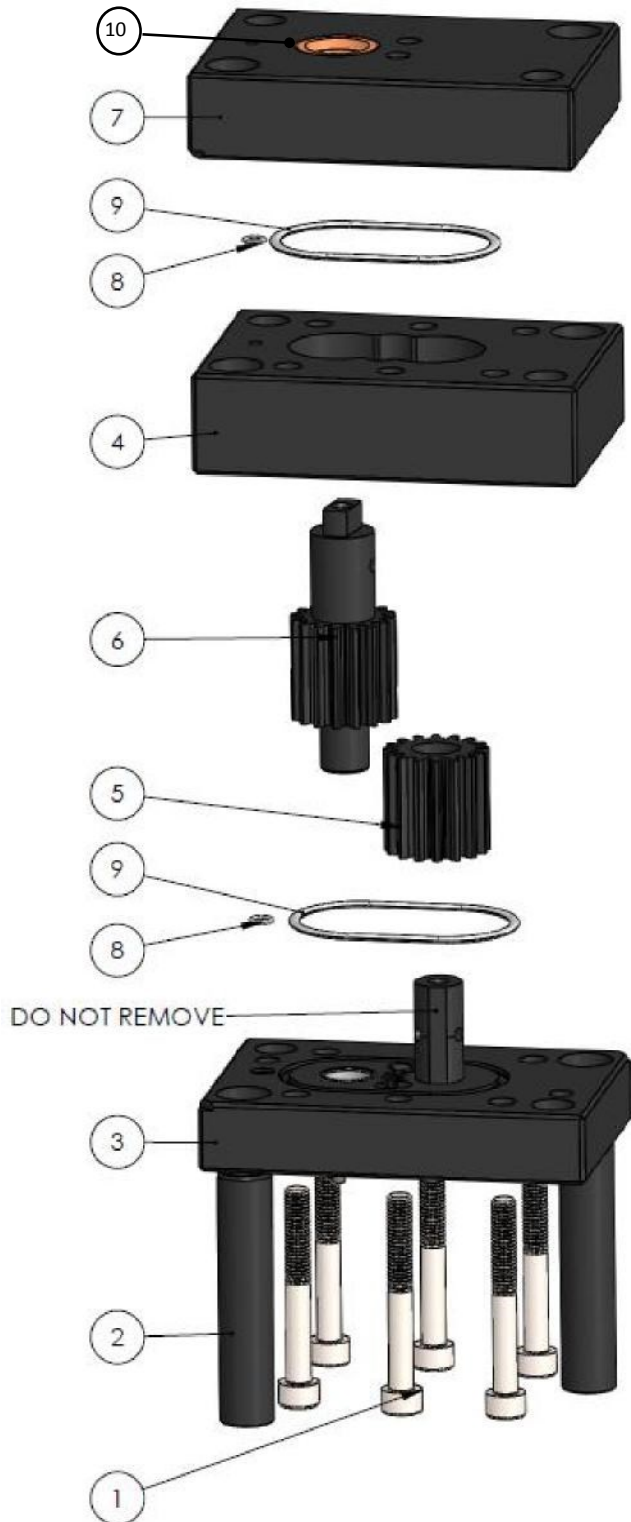

**PUMP REASSEMBLY**

1. Install new seal (#10) into front plate. Press seal into place using deep well socket or equivalent press tool. Spring side of seal faces down, press until flush.
2. Install new O-rings (#8 & #9) onto bottom plate.
3. Place driven gear (#5) back onto fixed shaft on bottom plate.
4. Install middle plate (#4).
5. Install drive shaft and gear (#6) into bottom plate assembly.
6. Install O-rings (#8 & #9) into grooves on top of plate.
7. Assemble top plate (#3) onto pump assembly
8. Press alignment pins back into pump carefully.
9. Reinstall bolts (#1), and tighten in a star pattern. Torque to 13 Lb-Ft (15 Nm). Note: Drive shaft of pump should be manually turned during the bolt tightening process to assure free spinning gears.
10. Set alignment pins so they protrude out by 2.5mm from front plate.

 <b>CAUTION</b>
<p>► Be careful not to scratch or nick any surface of the plates, seals, gears, and dowels inside the pump. These parts have very precise tolerances. Burrs, nicks, scratches, or particles of foreign matter will cause scoring and possibly pump seizure.</p>

## DLC Coated Flushable Pump—Cont'd

### FLUSHABLE PUMP PARTS LISTING

SEE FIGURE 1-4 EXPLODED PUMP VIEW

ITEM	QTY	PART NUMBER	DESCRIPTION	COMMENTS
1	6	-----	M6 BOLT	SOURCE LOCAL
2	2	-----	PIN, ALIGNMENT	N/A
3	1	-----	PLATE, BOTTOM	N/A
4	1		PLATE,CENTER	SEE KIT CHART "B" BELOW
5	1		GEAR, DRIVEN	SEE KIT CHART "B" BELOW
6	1		GEAR	SEE KIT CHART "B" BELOW
7	1	-----	KEYWAY	N/A
8	2	A13790-00*	O-RING	*INCLUDED IN A13790 KIT
9	2	A13790-00*	O-RING	*INCLUDED IN A13790 KIT
10	1	22-315*	SEAL,RADIAL	*INCLUDED IN A13790 KIT

### FLUSHABLE PUMP KIT GEARS & SPACER PLATE

CHART "B" FIELD PUMP REPAIR KIT (HARD PARTS)

PUMP KIT #	DESCRIPTION	USED ON PUMP #	SIZE CC'S
A13792-05	KIT, GEARS & SPACER PLATE 3.5 CC DLC PUMP	A13622-00	3.5
A13792-06	KIT, GEARS & SPACER PLATE 6.0 CC DLC PUMP	A13623-00	6.0
A13792-07	KIT, GEARS & SPACER PLATE 9.7 CC DLC PUMP	A13624-00	9.7



**DLC COATED NON-FLUSHABLE PUMP SERVICE**



**MODELS COVERED:**

A13619-00 .3 cc/rev A13621-00 1.8 cc/rev  
 A13620-00 .6 cc/rev A13635-00 3.0 cc/rev

**PUMP DISASSEMBLY**

1. Carefully press out the alignment pins.
2. Unscrew item #1 (the 6 M6 bolts) from the bottom of the pump.
3. Remove the top plate (#14) carefully with drive shaft and gear.
4. To remove the drive shaft (#8) with gear (#5), remove circlip (#6), slide gear off, remove key, then remove second circlip. Shaft will slide out though shaft seal (#15). Note: it will only slide out in one direction.
5. Remove the center plate (#9) carefully.
6. Slide drive gear off of shaft.
7. Pull seal (#15) from front plate (use seal puller or drive from opposite side). Be careful not to damage the pump bore during removal.

**Please Note:** Driven shaft (#4) is fixed in the body and cannot be removed. **(DO NOT ATTEMPT TO REMOVE THE FIXED SHAFT!)**

**PUMP CLEANING PROCESS**

1. All parts should be cleaned with a suitable cleaning agent. **(CLEANING WITH ABRASIVE MATERIALS WILL DAMAGE THE PUMP AND VOID WARRANTY!)**
2. Discard all used O-rings (#10) and replace during reassembly.
3. Pump plates should be dried with lint free towel and lubricated before reassembly with wet-sol or equivalent material.

**FIGURE 1-1 EXPLODED PUMP VIEW**

## DLC COATED NON-FLUSHABLE PUMP—Cont'd

FIGURE 1-2 EXPLODED PUMP VIEW

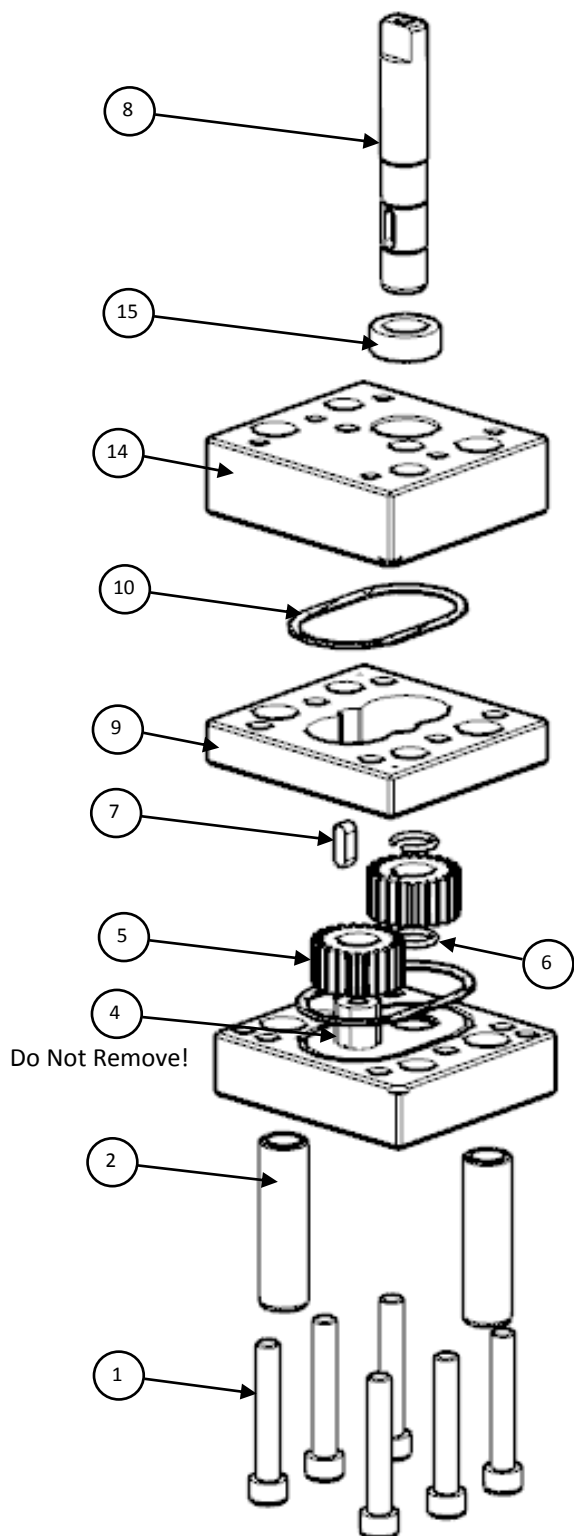

### PUMP REASSEMBLY

1. Slide new seal (#15) onto drive shaft approximately to the position that balloon 8 points to in figure at left. The spring side of the seal points down.
2. Bring shaft with seal down onto front plate.
3. Press seal into place using deep well socket or equivalent press tool. Allow shaft to move with seal while pressing into place. A 0.002" feeler gauge may be used as a guide to get seal started into housing.
4. Install circlip on drive shaft closest to front plate.
5. Install key (#7). Slide on drive gear (#5) and install second circlip.
6. Install a new O-ring (#10) on bottom plate and top plate in appropriate O-ring grooves.
7. Place driven gear back onto fixed shaft on bottom plate.
8. Install middle plate (#9).
9. Assemble top plate (#14) onto pump.
10. Press alignment pins back into pump carefully.
11. Reinstall bolts (#1). Tighten them in a star pattern and torque them to 13 Lb-Ft (15 Nm). Note: Drive shaft of pump should be manually turned during the bolt tightening process to assure free spinning gears.
12. Set alignment pins so they protrude out by 2.5mm from front plate.

### CAUTION

► Be careful not to scratch or nick any surface of the plates, seals, gears, and dowels inside the pump. These parts have very precise tolerances. Burrs, nicks, scratches, or particles of foreign matter will cause scoring and possibly pump seizure.

**DLC COATED NON-FLUSHABLE PUMP—Cont'd**

**NON-FLUSHABLE PUMP PARTS LISTING**

SEE FIGURE 1-2 EXPLODED PUMP VIEW

ITEM	QTY	PART NUMBER	DESCRIPTION	COMMENTS
1	6	-----	M6 BOLT	SOURCE LOCAL
2	2	-----	PIN, ALIGNMENT	N/A
3	1	-----	PLATE, BOTTOM	N/A
4	---	-----	-----	
5	2	A13792-XX	GEAR	SEE KIT CHART "A" BELOW
6	2	A13792-XX	CIRCLIP	SEE KIT CHART "A" BELOW
7	1	-----	KEYWAY	N/A
8	1	-----	SHAFT, MAIN	N/A
9	1	A13792-XX	PLATE, CENTER	SEE KIT CHART "A" BELOW
10	2	A13791-00*	O-RING	*INCLUDED IN A13791 KIT
11	---	-----	-----	
12	---	-----	-----	
13	---	-----	-----	
14	---	-----	PLATE, TOP	N/A
15	1	22-383*	SEAL, RADIAL	*INCLUDED IN A13791 KIT

**NON-FLUSHABLE PUMP KIT GEARS & SPACER PLATE**

CHART "A" FIELD PUMP REPAIR KIT (HARD PARTS)

PUMP KIT #	DESCRIPTION	USED ON PUMP #	SIZE CC'S
A13792-01	KIT, GEARS & SPACER PLATE 0.3 CC DLC PUMP	A13619-00	0.3
A13792-02	KIT, GEARS & SPACER PLATE 0.6 CC DLC PUMP	A13620-00	0.6
A13792-03	KIT, GEARS & SPACER PLATE 1.8 CC DLC PUMP	A13621-00	1.8
A13792-04	KIT, GEARS & SPACER PLATE 3.0 CC DLC PUMP	A13635-00	3.0

---

# MAINTENANCE

---

## CALIBRATION

The calibration value will vary based on viscosity, flow rate, temperature, and other factors. Refer to appropriate associated equipment for calibration procedure.

## TROUBLESHOOTING

**Gear Pump problems can be caused by improperly filtered fluid.** Particulates in the fluid can cause gear binding. Maintain the fluid filters according to the instructions from the filter manufacturer. If repeated disassembly and cleaning for removal of solids and particulates occurs, inspect the entire fluid supply system and evaluate the system cleaning cycle.

## SERVICING

Depressurize the gear pumps before attempting to remove from manifold. Remove the gear pump for service to a suitable clean area to perform maintenance. Using a hex key wrench, remove all 4 bolts. See pages 11-15 for teardown and reassembly procedures for both series of gear pumps.

---

# APPENDIX A

---

## Installation of Shaft Seals

There have been some issues in the field where the 22-315 and 22-383 shaft seals are being damaged using the old 22-252 and 22-543 installation tools when installing them in the newer style pumps. We have developed a series of tools which makes installation much easier with almost no chance of damaging the seals. This instruction outlines the procedure for using these new tools.

### For the Flushable (Resin) Style Pumps:

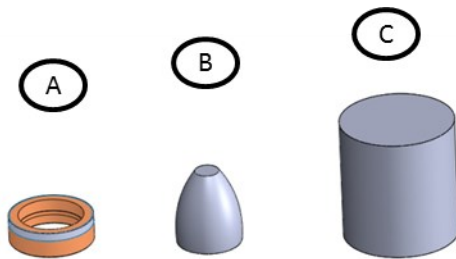

### Parts Required:

A-Shaft Seal: 22-315  
B-Shaft Cone: A14243-00  
C-Seal Driver: A14244-00

### Notes:

\*All orings should already be installed in pump housing with fixing bolts properly torqued

\*\*Wet-sol lubricant should be used on shaft seal ID and OD during installation.



1. Place Shaft Cone on pump shaft with new Seal resting on top of cone.

## APPENDIX A (cont.)

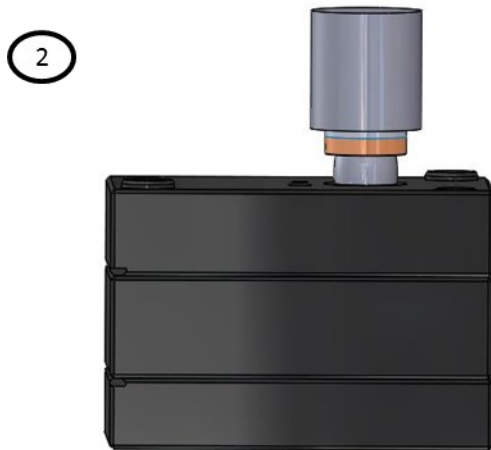

- Place drive tool on top of seal.  
Using a press, bring seal down into front plate of pump so it is flush to the face of the pump.

### For the Non-Flushable (Catalyst) Pumps:

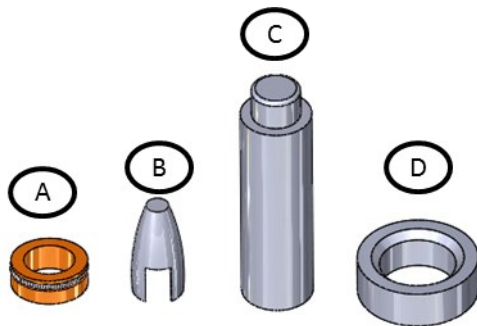

### Parts Required:

- A-Shaft Seal: 22-383
- B-Shaft Cone: A14239-00
- C-Drive Tool: A14240-00
- D-Slide Ring: A14241-00

### Notes:

\*All orings should already be installed in pump housing with fixing bolts properly torqued

\*\*Wet-sol lubricant should be used on shaft seal ID and OD during installation.



- Load shaft seal on to drive tool as shown.

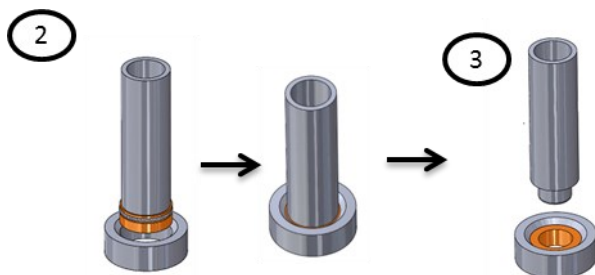

- Press seal into Slide Ring using the chamfer side of Ring to guide until Drive tool touches surface below Ring.
- Remove drive tool, leaving seal "loaded" in Seal Ring.

---

## APPENDIX A (cont.)

---

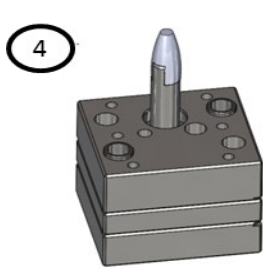

4

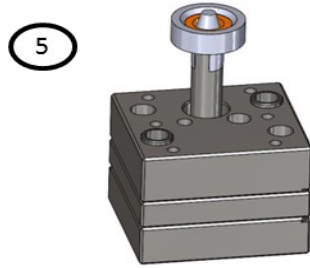

5

4. Place Cone on pump shaft so no sharp edges are exposed.

5. Place Seal on top of Cone while loaded in Slide Ring.

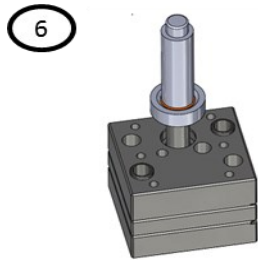

6

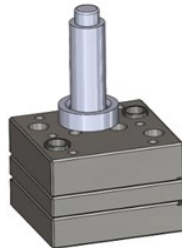

6. Using hollow side of drive tool, place over Cone and press Seal down evenly until it pushes through Seal ring and into front plate of pump.

(Proper installation should have seal flush on face of pump.)

---

## WARRANTY POLICIES

---

### LIMITED WARRANTY

Ransburg will replace or repair without charge any part and/or equipment that falls within the specified time (see below) because of faulty workmanship or material, provided that the equipment has been used and maintained in accordance with Ransburg's written safety and operating instructions, and has been used under normal operating conditions. Normal wear items are excluded.

#### **THE USE OF OTHER THAN RANSBURG APPROVED PARTS, VOID ALL WARRANTIES.**

**SPARE PARTS:** One hundred and eighty (180) days from date of purchase, except for rebuilt parts (any part number ending in "R") for which the warranty period is ninety (90) days.

**EQUIPMENT:** When purchased as a complete unit, (i.e., guns, power supplies, control units, etc.), is one (1) year from date of purchase.

**WRAPPING THE APPLICATOR, ASSOCIATED VALVES AND TUBING, AND SUPPORTING HARDWARE IN PLASTIC, SHRINK-WRAP, OR ANY OTHER NON-APPROVED COVERING, WILL VOID THIS WARRANTY.**

**RANSBURG'S ONLY OBLIGATION UNDER THIS WARRANTY IS TO REPLACE PARTS THAT HAVE FAILED BECAUSE OF FAULTY WORKMANSHIP OR MATERIALS. THERE ARE NO IMPLIED WARRANTIES NOR WARRANTIES OF EITHER MERCHANTABILITY OR FITNESS FOR A PARTICULAR PURPOSE. RANSBURG ASSUMES NO LIABILITY FOR INJURY, DAMAGE TO PROPERTY OR FOR CONSEQUENTIAL DAMAGES FOR LOSS OF GOODWILL OR PRODUCTION OR INCOME, WHICH RESULT FROM USE OR MISUSE OF THE EQUIPMENT BY PURCHASER OR OTHERS.**

#### EXCLUSIONS:

If, in Ransburg's opinion the warranty item in question, or other items damaged by this part was improperly installed, operated or maintained, Ransburg will assume no responsibility for repair or replacement of the item or items. The purchaser, therefore will assume all responsibility for any cost of repair or replacement and service related costs if applicable.



---

# **MANUAL UPDATES**

---

- LN-9415-02 (March 2017) - Appendix A (Installation of Shaft Seals) added.

# Ransburg

## **Manufacturing**

1910 North Wayne Street  
Angola, Indiana 46703-9100  
Telephone: 260-665-8800  
Fax: 260-665-8516

## **Technical Service — Assistance**

320 Philips Ave.  
Toledo, Ohio 43612-1493  
Telephone (toll free): 800-233-3366  
Fax: 419-470-2233  
[www.ransburg.com](http://www.ransburg.com)

**Technical Support Representative will direct you to the appropriate telephone number for ordering Spare Parts.**