

Ransburg RMA-550 Rotary Atomizer



FM APPROVED



Model: A13852

IMPORTANT: Before using this equipment, carefully read SAFETY PRECAUTIONS and all instructions in this manual. Keep this Service Manual for future reference.

NOTE: This manual has been changed from revision **LN-9284-15-R4** to revision **LN-9284-15-R5**. Reasons for this change are noted under “Manual Change Summary” inside the back cover of this manual.

CONTENTS

SAFETY:	5-9
Safety Precautions	5
Hazards / Safeguards	6
CONFIGURATIONS:	10-20
Ordering Instructions	10
Drawings and Tables	11
INTRODUCTION:	21-39
Applicator Description	21
Features	21
General Description	22
Specifications	24
Important Numbers	26
Graphs	27
Tool Point Dimensions	32
Circuit Schematic (Dual Purge)	36
Valve Schematic (Dual Purge)	37
Circuit Schematic (Single Purge)	38
Valve Schematic (Single Purge)	39
INSTALLATION:	40-51
Air Filter Installation (General Guidelines)	40
Equipment Grounding/Safety Recommendations	41
Air Heater Requirements	43
Air Heater and Filtration Options	43
A13230-XX Air Heater and Filter Combination	45
Mounting	46
Electrical and Fiber Optic Connections	47
Fluid Connections	48
Dual Purge Manifold	48
Single Purge Manifold	48
Typical Installation	48
Typical Installation of RMA-550	49
Tubing Bundle Installation	50
Bundle Lubricant	50
Interlocks	51
OPERATION:	52-59
Fluid Flow Rate Control	52
Dual Purge Spraying	53
Turbine Speed	53
Bearing Air Adjustment	54
Shaping Air Kits 1-4	54
Brake Air	55

(Continued On Next Page)

CONTENTS (Cont.)

OPERATION (Cont.):	52-59
Electrostatic Voltage	55
Target Distance	55
General Operating Sequence	55
Low Voltage Cable Installation and Removal	57
Low Voltage Cable on Robot	59
Turbine Air	59
MAINTENANCE:	60-87
O-Rings	60
Cleaning Procedures	61
Vibration Noise	62
Turbine Maintenance	62
General/Preventive Maintenance	62
Preventive Maintenance	62
Bell Cup Preventive Maintenance	64
Bell Cup Cleaning	64
Cleaning Shaping Air Holes	66
Bell Cup Testing (Non-Rotating)	66
Operator/Maintenance Warnings	67
Preventive Maintenance Schedule	68
Disassembly Procedures	69
Cup Wash Connections For Single Purge Manifold	78
Cup Wash Connections For Dual Purge Manifold	78
Shape Air Manifold Cup Wash Connection	79
Tubing Bundle Assembly - Fitting Installation and Tubing Repair	80
Troubleshooting Guide	84
PARTS IDENTIFICATION:	88-113
RMA-550 Rotary Atomizer Model Identification	88
Bell Cup Assembly	90
RMA-550 Assembly	92
RMA-550 Rotary Atomizer Assembly	96
A13430-00 Rear Plate Assembly - Parts List	97
Valve Manifold Assembly	98
Shaping Air Kit Assembly Parts Breakdown	101
Tubing Bundle Assembly	102
Tubing Bundle Assembly Model Identification - Parts List	103
Tubing Bundle Nomenclature	106
Atomizer Recommended Spare Parts	107
Tubing Bundle Recommended Spare Parts	109
Assembly Tools	111
Filter and Heater Assembly A13230-XX	112
A13230-XX Air Heater and Filter Combination	112
Service Kits / Accessories	113
MANUAL CHANGE SUMMARY:	114
Manual Changes	114

SAFETY

SAFETY PRECAUTIONS

Before operating, maintaining or servicing any electrostatic coating system, read and understand all of the technical and safety literature for your products. This manual contains information that is important for you to know and understand. This information relates to **USER SAFETY** and **PREVENTING EQUIPMENT PROBLEMS**. To help you recognize this information, we use the following symbols. Please pay particular attention to these sections.

WARNING

A **WARNING!** states information to alert you to a situation that might cause serious injury if instructions are not followed.

CAUTION

A **CAUTION!** states information that tells how to prevent damage to equipment or how to avoid a situation that might cause minor injury.

NOTE

A **NOTE** is information relevant to the procedure in progress.

While this manual lists standard specifications and service procedures, some minor deviations may be found between this literature and your equipment. Differences in local codes and plant requirements, material delivery requirements, etc., make such variations inevitable. Compare this manual with your system installation drawings and associated equipment manuals to reconcile such differences.

Careful study and continued use of this manual will provide a better understanding of the equipment and process, resulting in more efficient operation, longer trouble-free service and faster, easier troubleshooting. If you do not have the manuals and safety literature for your equipment, contact your local Carlisle Fluid Technologies representative or Carlisle Fluid Technologies technical support.

WARNING



- The user **MUST** read and be familiar with the Safety Section in this manual and the safety literature therein identified.
- This equipment is intended to be used by trained personnel **ONLY**.
- This manual **MUST** be read and thoroughly understood by **ALL** personnel who operate, clean or maintain this equipment! Special care should be taken to ensure that the **WARNINGS** and safety requirements for operating and servicing the equipment are followed. The user should be aware of and adhere to **ALL** local building and fire codes and ordinances as well as **NFPA-33 AND EN 50177 SAFETY STANDARDS, LATEST EDITION**, or applicable country safety standards, prior to installing, operating, and/or servicing this equipment.

WARNING



- The hazards shown on the following pages may occur during the normal use of this equipment.

Repairs may only be performed by authorized personnel.

AREA Tells where hazards may occur.	HAZARD Tells what the hazard is.	SAFEGUARDS Tells how to avoid the hazard.
<p>Spray Area</p> 	<p>Fire Hazard</p> <p>Improper or inadequate operation and maintenance procedures will cause a fire hazard.</p> <p>Protection against inadvertent arcing that is capable of causing fire or explosion is lost if any safety interlocks are disabled during operation. Frequent Power Supply or Controller shutdown indicates a problem in the system requiring correction.</p>	<p>Fire extinguishing equipment must be present in the spray area and tested periodically.</p> <p>Spray areas must be kept clean to prevent the accumulation of combustible residues.</p> <p>Smoking must never be allowed in the spray area.</p> <p>The high voltage supplied to the atomizer must be turned off prior to cleaning, flushing or maintenance.</p> <p>Spray booth ventilation must be kept at the rates required by NFPA-33, OSHA, country, and local codes. In addition, ventilation must be maintained during cleaning operations using flammable or combustible solvents.</p> <p>Electrostatic arcing must be prevented. Safe sparking distance must be maintained between the parts being coated and the applicator. A distance of 1 inch for every 10KV of output voltage is required at all times.</p> <p>Test only in areas free of combustible material. Testing may require high voltage to be on, but only as instructed.</p> <p>Non-factory replacement parts or unauthorized equipment modifications may cause fire or injury. If used, the key switch bypass is intended for use only during setup operations. Production should never be done with safety interlocks disabled.</p> <p>The paint process and equipment should be set up and operated in accordance with NFPA-33, NEC, OSHA, local, country, and European Health and Safety Norms.</p>

<p>AREA Tells where hazards may occur.</p>	<p>HAZARD Tells what the hazard is.</p>	<p>SAFEGUARDS Tells how to avoid the hazard.</p>
<p>Spray Area</p> 	<p>Explosion Hazard</p> <p>Improper or inadequate operation and maintenance procedures will cause a fire hazard.</p> <p>Protection against inadvertent arcing that is capable of causing fire or explosion is lost if any safety interlocks are disabled during operation.</p> <p>Frequent Power Supply or Controller shutdown indicates a problem in the system requiring correction.</p>	<p>Electrostatic arcing must be prevented. Safe sparking distance must be maintained between the parts being coated and the applicator. A distance of 1 inch for every 10KV of output voltage is required at all times.</p> <p>Unless specifically approved for use in hazardous locations, all electrical equipment must be located outside Class I or II, Division 1 or 2 hazardous areas, in accordance with NFPA-33.</p> <p>Test only in areas free of flammable or combustible materials.</p> <p>The current overload sensitivity (if equipped) MUST be set as described in the corresponding section of the equipment manual. Protection against inadvertent arcing that is capable of causing fire or explosion is lost if the current overload sensitivity is not properly set. Frequent power supply shutdown indicates a problem in the system which requires correction.</p> <p>Always turn the control panel power off prior to flushing, cleaning, or working on spray system equipment.</p> <p>Before turning high voltage on, make sure no objects are within the safe sparking distance.</p> <p>Ensure that the control panel is interlocked with the ventilation system and conveyor in accordance with NFPA-33, EN 50176.</p> <p>Have fire extinguishing equipment readily available and tested periodically.</p>
<p>General Use and Maintenance</p> 	<p>Improper operation or maintenance may create a hazard.</p> <p>Personnel must be properly trained in the use of this equipment.</p>	<p>Personnel must be given training in accordance with the requirements of NFPA-33, EN 60079-0.</p> <p>Instructions and safety precautions must be read and understood prior to using this equipment.</p> <p>Comply with appropriate local, state, and national codes governing ventilation, fire protection, operation maintenance, and housekeeping. Reference OSHA, NFPA-33, EN Norms and your insurance company requirements.</p>

AREA Tells where hazards may occur.	HAZARD Tells what the hazard is.	SAFEGUARDS Tells how to avoid the hazard.
<p>Spray Area / High Voltage Equipment</p> 	<p>Electrical Discharge</p> <p>There is a high voltage device that can induce an electrical charge on ungrounded objects which is capable of igniting coating materials.</p> <p>Inadequate grounding will cause a spark hazard. A spark can ignite many coating materials and cause a fire or explosion.</p>	<p>Parts being sprayed and operators in the spray area must be properly grounded.</p> <p>Parts being sprayed must be supported on conveyors or hangers that are properly grounded. The resistance between the part and earth ground must not exceed 1 megohm. (Refer to NFPA-33.)</p> <p>Operators must be grounded. Rubber soled insulating shoes should not be worn. Grounding straps on wrists or legs may be used to assure adequate ground contact.</p> <p>Operators must not be wearing or carrying any ungrounded metal objects.</p> <p>When using an electrostatic handgun, operators must assure contact with the handle of the applicator via conductive gloves or gloves with the palm section cut out.</p> <p>NOTE: REFER TO NFPA-33 OR SPECIFIC COUNTRY SAFETY CODES REGARDING PROPER OPERATOR GROUNDING.</p> <p>All electrically conductive objects in the spray area, with the exception of those objects required by the process to be at high voltage, must be grounded. Grounded conductive flooring must be provided in the spray area.</p> <p>Always turn off the power supply prior to flushing, cleaning, or working on spray system equipment.</p> <p>Unless specifically approved for use in hazardous locations, all electrical equipment must be located outside Class I or II, Division 1 or 2 hazardous areas, in accordance with NFPA-33.</p> <p>Avoid installing an applicator into a fluid system where the solvent supply is ungrounded.</p> <p>Do not touch the applicator electrode while it is energized.</p>

<p>AREA Tells where hazards may occur.</p>	<p>HAZARD Tells what the hazard is.</p>	<p>SAFEGUARDS Tells how to avoid the hazard.</p>
<p>Electrical Equipment</p> 	<p>Electrical Discharge</p> <p>High voltage equipment is utilized in the process. Arcing in the vicinity of flammable or combustible materials may occur. Personnel are exposed to high voltage during operation and maintenance.</p> <p>Protection against inadvertent arcing that may cause a fire or explosion is lost if safety circuits are disabled during operation.</p> <p>Frequent power supply shut-down indicates a problem in the system which requires correction.</p> <p>An electrical arc can ignite coating materials and cause a fire or explosion.</p>	<p>Unless specifically approved for use in hazardous locations, the power supply, control cabinet, and all other electrical equipment must be located outside Class I or II, Division 1 and 2 hazardous areas in accordance with NFPA-33 and EN 50176.</p> <p>Turn the power supply OFF before working on the equipment.</p> <p>Test only in areas free of flammable or combustible material.</p> <p>Testing may require high voltage to be on, but only as instructed.</p> <p>Production should never be done with the safety circuits disabled.</p> <p>Before turning the high voltage on, make sure no objects are within the sparking distance.</p>
<p>Toxic Substances</p> 	<p>Chemical Hazard</p> <p>Certain materials may be harmful if inhaled, or if there is contact with the skin.</p>	<p>Follow the requirements of the Safety Data Sheet supplied by coating material manufacturer.</p> <p>Adequate exhaust must be provided to keep the air free of accumulations of toxic materials.</p> <p>Use a mask or respirator whenever there is a chance of inhaling sprayed materials. The mask must be compatible with the material being sprayed and its concentration. Equipment must be as prescribed by an industrial hygienist or safety expert, and be NIOSH approved.</p>
<p>Spray Area</p> 	<p>Explosion Hazard — Incompatible Materials</p> <p>Halogenated hydrocarbon solvents for example: methylene chloride and 1,1,1, - Trichloroethane are not chemically compatible with the aluminum that might be used in many system components. The chemical reaction caused by these solvents reacting with aluminum can become violent and lead to an equipment explosion.</p>	<p>Spray applicators require that aluminum inlet fittings be replaced with stainless steel.</p> <p>Aluminum is widely used in other spray application equipment - such as material pumps, regulators, triggering valves, etc. Halogenated hydrocarbon solvents must never be used with aluminum equipment during spraying, flushing, or cleaning. Read the label or data sheet for the material you intend to spray. If in doubt as to whether or not a coating or cleaning material is compatible, contact your coating supplier. Any other type of solvent may be used with aluminum equipment.</p>

RMA-550 LABELS AND PRODUCT MARKINGS

LABELS



APPROVED
LSLA-0003-1

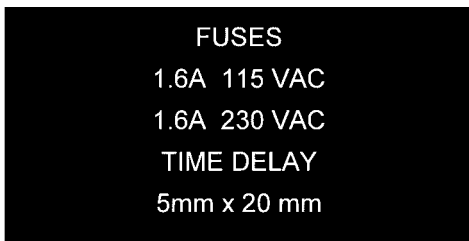

A13912-00



A13205-00



80491-00

Ransburg BRAND OF CARLISLE FLUID TECHNOLOGIES INC. SCOTTSDALE, AZ.

WARNING

FAILURE TO OBSERVE THE FOLLOWING PRECAUTIONS MAY RESULT IN AN ELECTRICAL DISCHARGE CAPABLE OF STARTING A FIRE.

1. THE ARTICLE BEING COATED MUST BE GROUNDED.
2. ALL OTHER ELECTRICALLY CONDUCTING OBJECTS WITHIN THE SPRAY BOOTH WITH THE SPRAY APPLICATOR MUST BE GROUNDED.
3. THIS SINGLE BELL CONTROLLER MUST BE INTERLOCKED WITH THE SPRAY BOOTH VENTILATORS SO AS TO PREVENT OPERATION OF THE POWER SUPPLY UNLESS VENTILATING FANS ARE IN OPERATION.
4. SERVICE WARNING - ENCLOSURE PROTECTS AGAINST SHOCK AND INJURY. SERVICE TRAINING REQUIRED.
5. KEEP THIS UNIT OUTSIDE THE HAZARDOUS AREA.
6. DO NOT ATTEMPT OPERATION OR REPAIR BEFORE READING SERVICE MANUAL.
7. FOR ELECTROSTATIC PAINT FINISHING APPLICATIONS.

SINGLE BELL CONTROLLER
FOR ELECTROSTATIC PAINT FINISHING APPLICATIONS
(SERIAL NUMBER INCLUDES DATE OF MANUFACTURE)

PART No.			
SERIAL No.			
INPUT VOLTAGE	100-240 VAC	1 A MAX.	INPUT RMS CURRENT PHASES
FREQUENCY	50 / 60 Hz	1	
VOLTAMPS	120 VA MAX.	22 VDC	MAX OUTPUT VOLTAGE MAX OUTPUT CURRENT TEMPERATURE
HUMIDITY	95% NON-CONDENSING	1 ADC	
INPUT PRESSURE	100 PSI MAX.	0 - 40°C	KA

SCCR



LABEL REMOVAL VOIDS WARRANTY

80542-01

PRODUCT MARKINGS



A11201

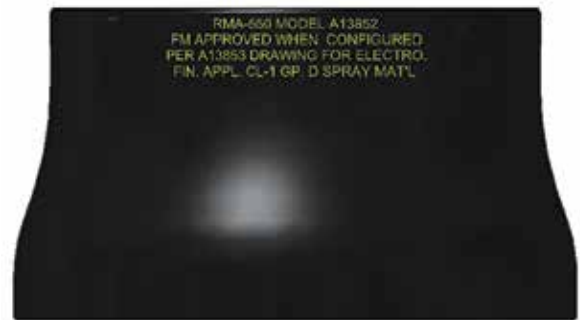

A13455-04

CONFIGURATIONS

This applicator is FM approved when configured to drawings shown on pages 7 through 16.

CONFIGURATION DRAWING A13853 ORDERING INSTRUCTIONS

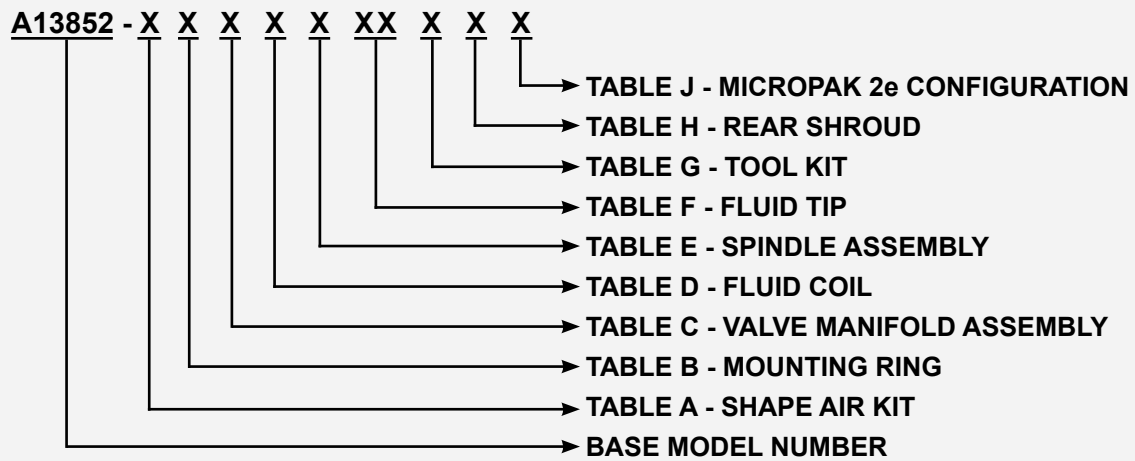

A13853 CONFIGURATION DRAWING

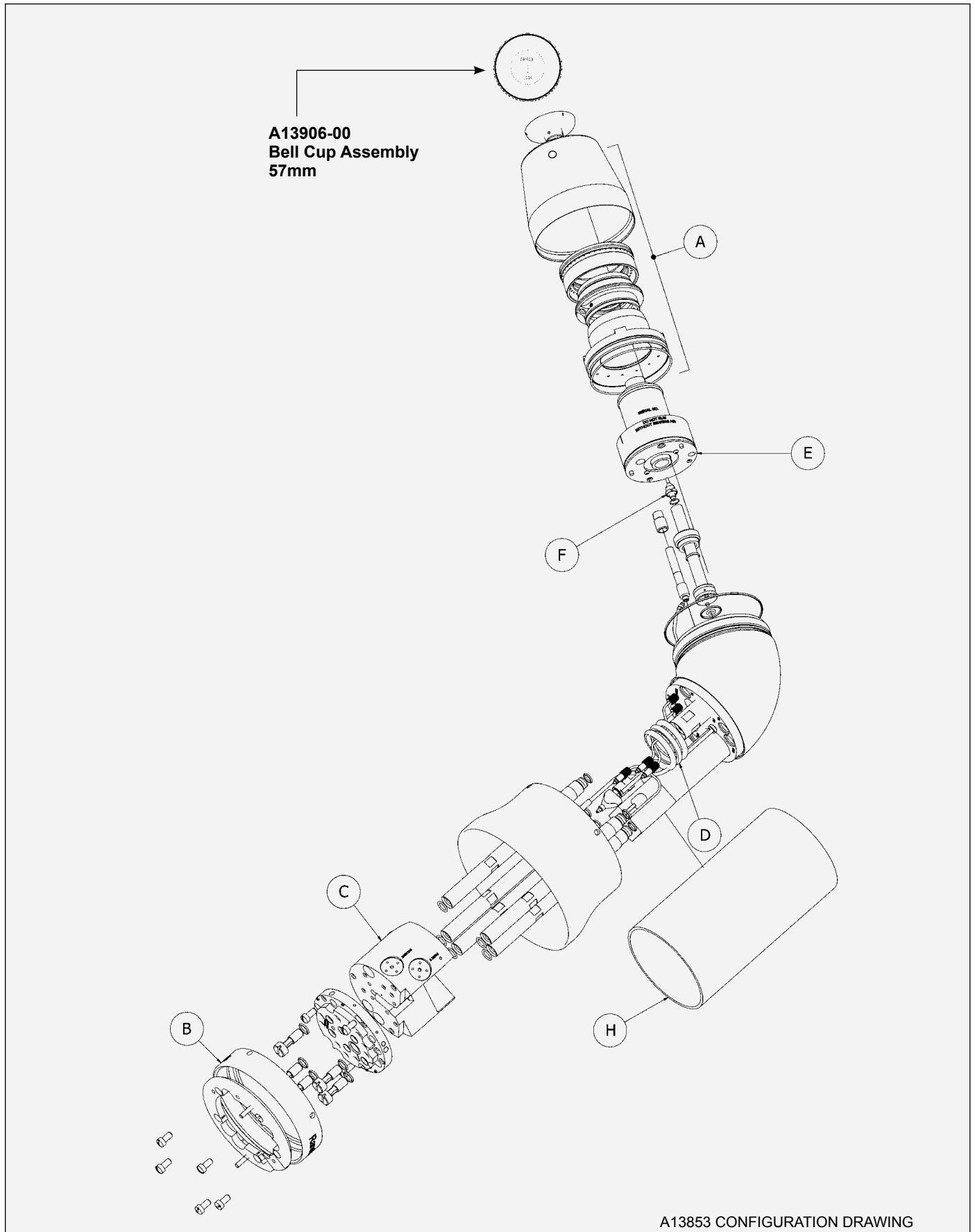

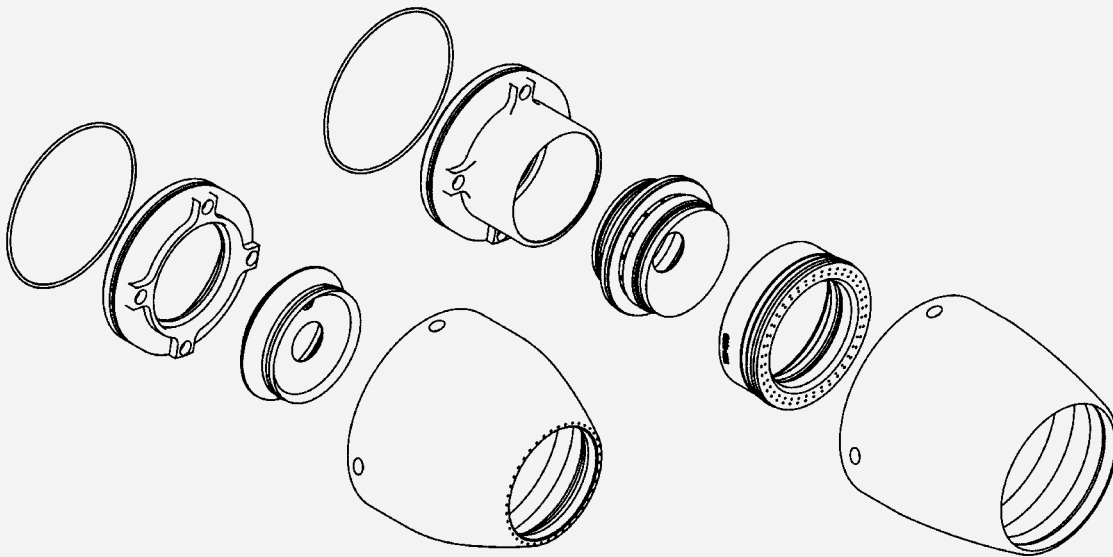

A12874-07 SINGLE SHAPE AIR

A12874-10 65MM DUAL SHAPE AIR

TABLE "A" - SHAPE AIR KITS

Dash No.	Part Number	Description
1	A12874-07	SINGLE SHAPE AIR (NON-METALLIC)
2	A12874-10	DUAL SHAPE AIR (NON-METALLIC)

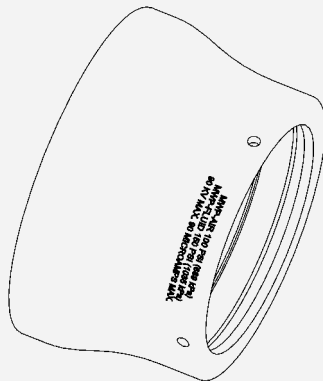

A13455-04

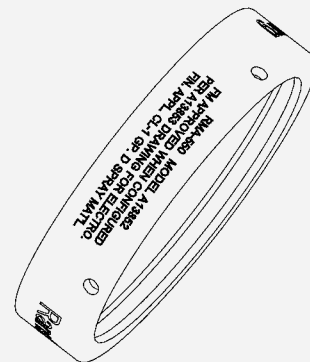

A11201-03

TABLE "B" - MOUNTING RING

Dash No.	Part Number	Description
1	A13455-04	PLASTIC WITH SKIRT EXTENSION - BLACK
2	A11201-03	STAINLESS STEEL

A13853 CONFIGURATION DRAWING

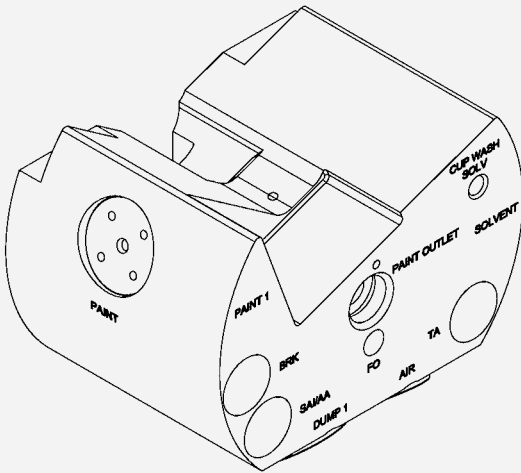

A13729-00
VALVE MANIFOLD
SINGLE PURGE

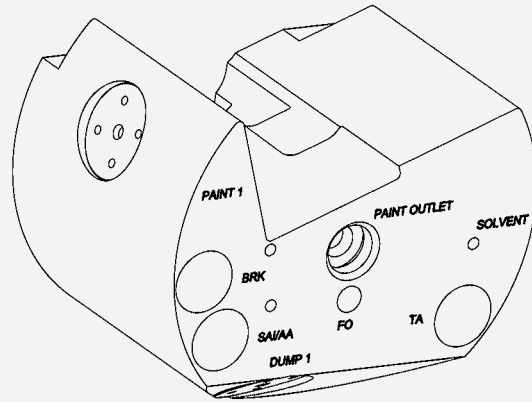

A13540-00
VALVE MANIFOLD
RMA SINGLE/DUAL PURGE

TABLE "C" - VALVE MANIFOLD ASSEMBLY

Dash No.	Part Number	Description
1	A13729-00	SINGLE PURGE/INTEGRATED CUP WASH VALVES
2	A13540-00	DUAL PURGE



77531-00
FOR HIGHLY
RESISTIVE
MATERIALS

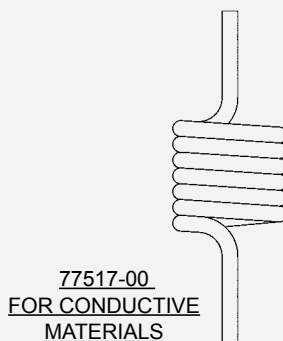

77517-00
FOR CONDUCTIVE
MATERIALS

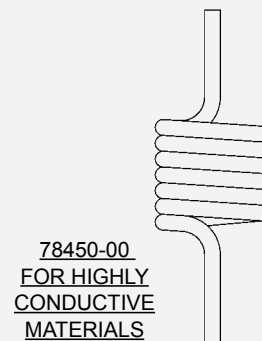

78450-00
FOR HIGHLY
CONDUCTIVE
MATERIALS

TABLE "D" - FLUID COIL

Dash No.	Part Number	Description
1	77531-00	.25 O.D. X .125 I.D. FOR HIGHLY RESISTIVE MATERIALS
2	77517-00	.25 O.D. X .170 I.D. FOR CONDUCTIVE MATERIALS
3	78450-00	.25 O.D. X .125 I.D. FOR HIGHLY CONDUCTIVE MATERIALS

A13853 CONFIGURATION DRAWING

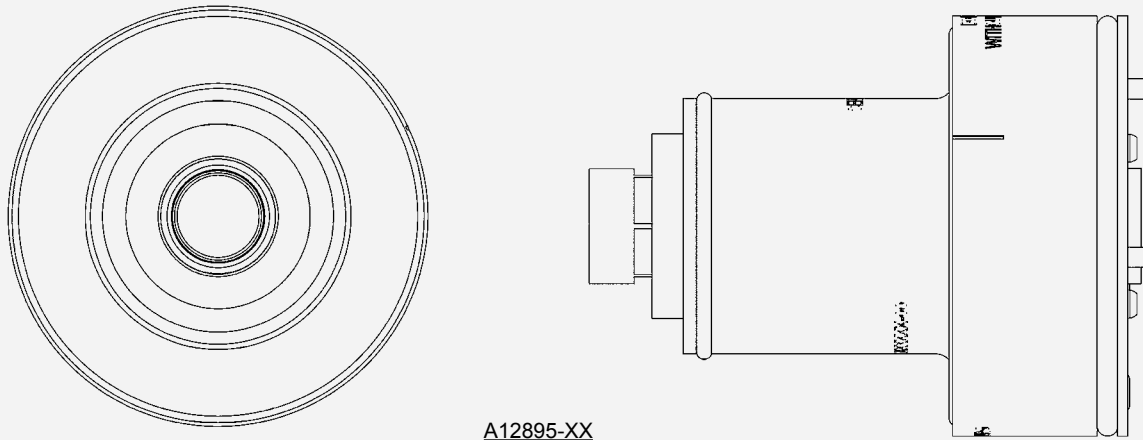

A12895-XX
SPINDLE ASSEMBLY

TABLE "E" - SPINDLE ASSEMBLY

Dash No.	Part Number	Description
1	A12895-01	SPINDLE ASSEMBLY, SILVER SHAFT
2	A12895-04	SPINDLE ASSEMBLY, BLACK SHAFT

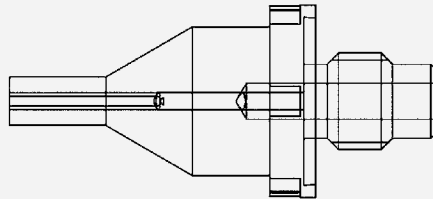

A13827-XX

TABLE "F" - FLUID TIP

Dash No.	Part Number	Description
01	A13827-01	.028/.7MM OPENING
02	A13827-02	.035/.9MM OPENING
03	A13827-03	.039/1.0MM OPENING
04	A13827-04	.043/1.1MM OPENING
05	A13827-05	.047/1.2MM OPENING
06	A13827-06	.051/1.3MM OPENING
07	A13827-07	.062/1.6MM OPENING

A13853 CONFIGURATION DRAWING

TABLE "G" - TOOL KIT

Dash No.	"G"	Tools Included
0	NONE	NONE
1	A13926-00	76772-01, A12088-00, A11229-00, A12061-00, 78279-00, A10766-00, LSCH0009-00, A13917-00, A11922-00, RPM-419-2, A13951-00

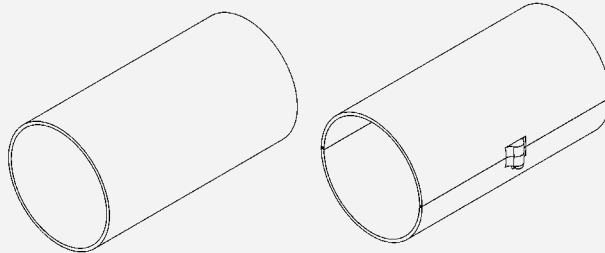

A13444-00
ROUND SHROUD LOGO

A13559-01
SPLIT SHROUD

TABLE "H" - REAR SHROUD

Dash No.	Part Number	Description
1	A13444-00	ROUND SHROUD/LOGO
2	A13559-01	SPLIT SHROUD

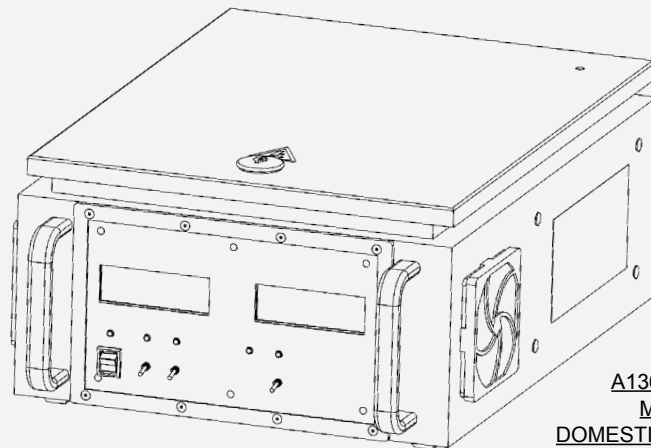

A13613-001714X111
MICROPAC 2e
DOMESTIC/EUROPEAN/CHINA

TABLE "J" - MICROPAC 2E CONFIGURATION

Dash No.	Part Number	Description
0	NONE	NONE
1	A13613-0017140111	MICROPAC 2e DOMESTIC AC INPUT
2	A13613-0017141111	MICROPAC 2e EUROPEAN AC INPUT
3	A13613-0017142111	MICROPAC 2e CHINA AC INPUT

A13853 CONFIGURATION DRAWING

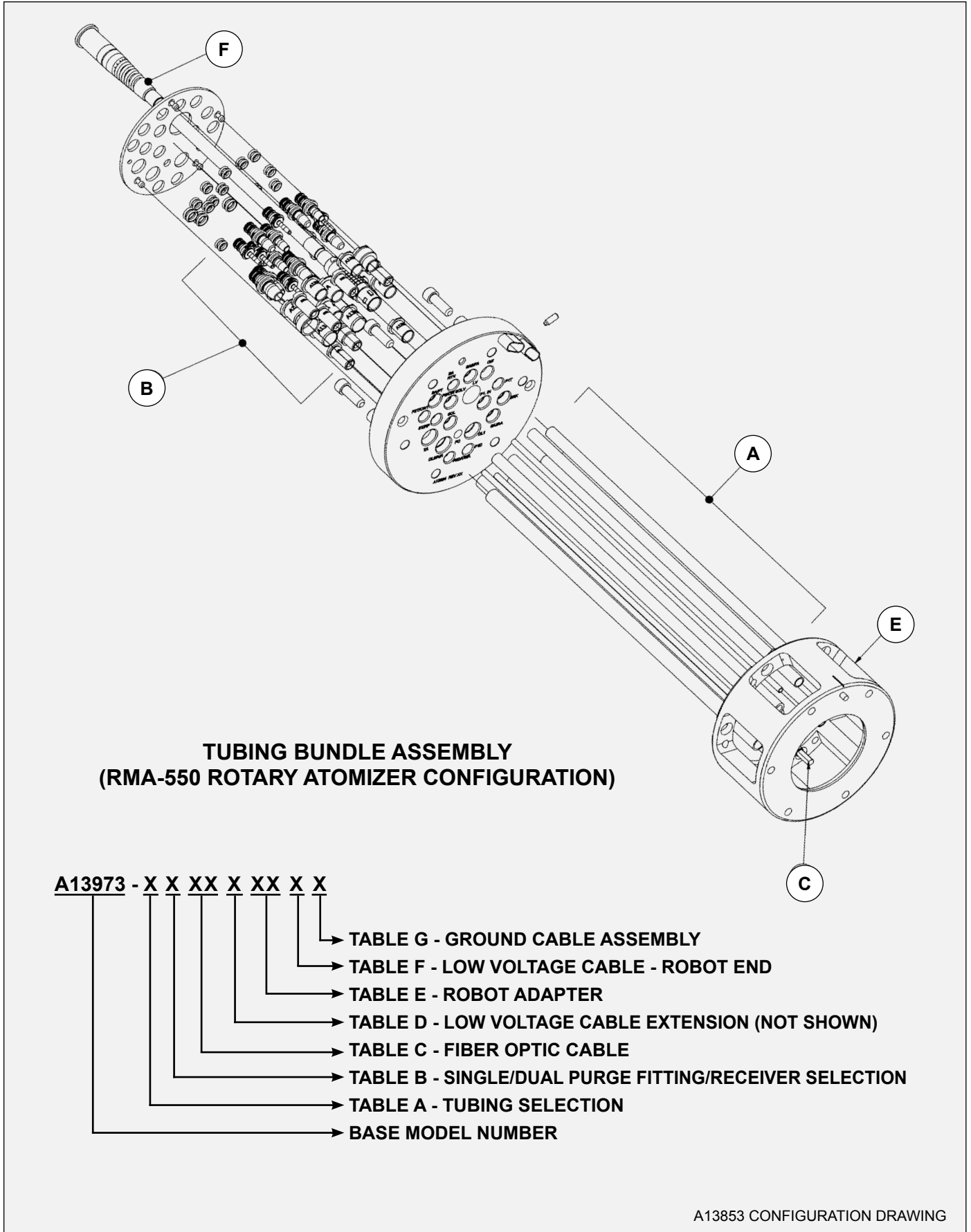

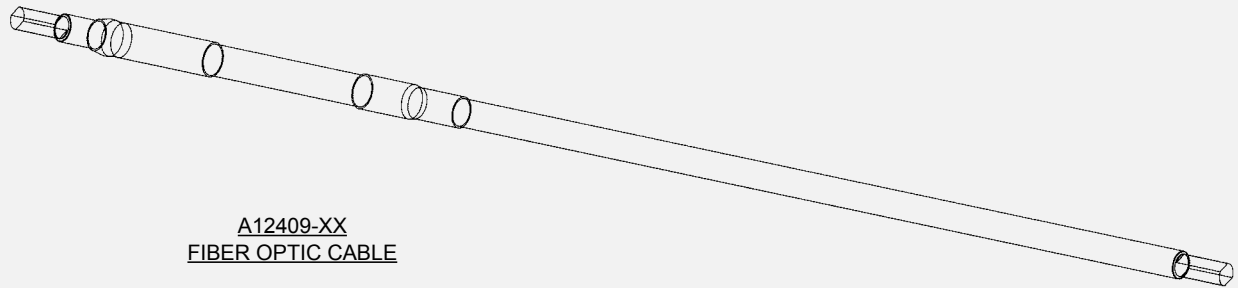

TABLE "A" - TUBING SELECTION

Dash #	Description	77536-05 QTY	77536-01 QTY	A12211-00 QTY	77536-03 QTY	77536-07 QTY	77536-06 QTY	77536-04 QTY	A10839-06 QTY	76698-02 QTY	A10893-07 QTY	A10893-04 QTY	A10893-10 QTY
0	No Tubing	None	None	None	None	None	None	None	None	None	None	None	None
1	Single/Dual Purge	42 ft.	42 ft.	42 ft.x2	42 ft.	42 ft.	42 ft.	42 ft.	6 ft.	42 ft.x4	42 ft.	42 ft.	42 ft.x2

TABLE "B" - SINGLE/DUAL PURGE FITTING/RECEIVER SELECTION

Dash #	Description	79001-04 QTY	79001-05 QTY	A13409-00 QTY	A13407-00 QTY	A13410-00 QTY	A13405-00 QTY	A13406-00 QTY	A13538-00 QTY	A13399-00 QTY	A13400-00 QTY
1	Single/Dual Purge	28	6	6	6	4	4	3	2	4	4

TABLE "C" - FIBER OPTIC CABLE LENGTH

Dash #	Description	"C"
00	FIBER OPTIC CABLE (NOT INCLUDED)	N/A
01	3 FT. LONG, FIBER OPTIC CABLE	A12409-01
02	6 FT. LONG FIBER OPTIC CABLE	A12409-02
03	10 FT. LONG FIBER OPTIC CABLE	A12409-03
04	15 FT. LONG FIBER OPTIC CABLE	A12409-04
05	25 FT. LONG FIBER OPTIC CABLE	A12409-05
06	40 FT. LONG FIBER OPTIC CABLE	A12409-06
07	50 FT. LONG FIBER OPTIC CABLE	A12409-07
08	65 FT. LONG FIBER OPTIC CABLE	A12409-08
09	75 FT. LONG FIBER OPTIC CABLE	A12409-09
10	100 FT. LONG FIBER OPTIC CABLE	A12409-10
11	120 FT. LONG, FIBER OPTIC CABLE	A12409-21

A13853 CONFIGURATION DRAWING



A12433-XX LOW VOLTAGE CABLE QUICK CONNECT

TABLE "D" - LOW VOLTAGE CABLE EXTENSION

Dash No.	Part Number	Description	Length
0	NONE	NONE	NONE
6	A12433-25	QUICK CONNECT TO MICROPAK - QUICK CONNECT ENDS	25 FT.
7	A12433-50	QUICK CONNECT TO MICROPAK - QUICK CONNECT ENDS	50 FT.
8	A12433-75	QUICK CONNECT TO MICROPAK - QUICK CONNECT ENDS	75 FT.

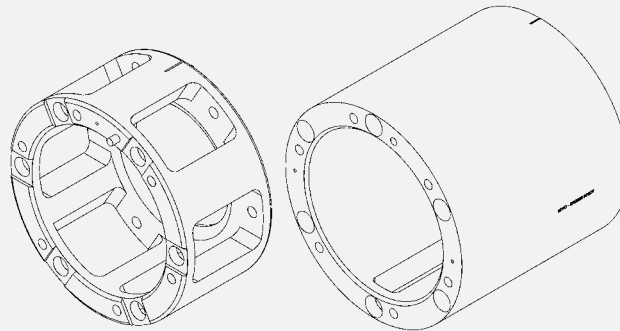

STANDARD LENGTH

EXTENDED LENGTH

TABLE "E" - ROBOT ADAPTER

Dash No.	Description	Part No.	Notes
00	ADAPTER NOT INCLUDED	N/A	NONE
01	FANUC P145/P155	78983-00	STANDARD LENGTH WITH WINDOWS
02	ABB 5400, 5002	79107-00	STANDARD LENGTH WITH WINDOWS
03	FANUC P200/P250	79131-00	STANDARD LENGTH WITH WINDOWS
04	KAWASAKI KE610L	A10847-00	STANDARD LENGTH WITH WINDOWS
05	MOTOMAN PX2850	A10848-00	STANDARD LENGTH WITH WINDOWS
06	MOTOMAN PX2900	A10849-00	STANDARD LENGTH WITH WINDOWS
07	B&M LZ2000	A10851-00	STANDARD LENGTH WITH WINDOWS
08	ABB 5400 ENHANCED WRIST	A12036-00	STANDARD LENGTH WITH WINDOWS
09	MOTOMAN EPX2050	A13697-00	STANDARD LENGTH WITH WINDOWS
10	FANUC P200-P250	A13733-00	EXTENDED LENGTH WITH 1 WINDOW
11	KAWASAKI KE610L	A13734-00	EXTENDED LENGTH WITH 1 WINDOW
12	ABB 5400 ENHANCED WRIST	A13735-00	EXTENDED LENGTH WITH 1 WINDOW
13	MOTOMAN EXP2050	A13736-00	EXTENDED LENGTH WITH 1 WINDOW

A13853 CONFIGURATION DRAWING

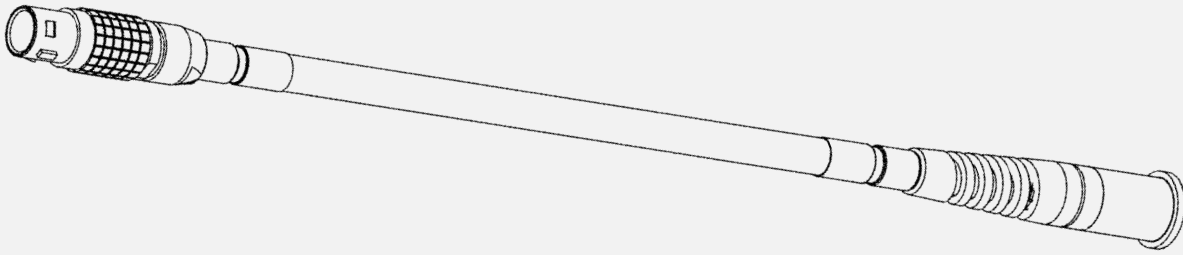

A12239-XX LOW VOLTAGE CABLE ROBOT END

TABLE "F" - LOW VOLTAGE CABLE - ROBOT END

Dash No.	Part Number	Description	Length
0	N/A	N/A	N/A
1	A12239-06	LOW VOLTAGE CABLE - QUICK DISCONNECT	6 FT.
2	A12239-10	LOW VOLTAGE CABLE - QUICK DISCONNECT	10 FT.
3	A12239-25	LOW VOLTAGE CABLE - QUICK DISCONNECT	25 FT.
4	A12239-50	LOW VOLTAGE CABLE - QUICK DISCONNECT	50 FT.
5	A12239-75	LOW VOLTAGE CABLE - QUICK DISCONNECT	75 FT.

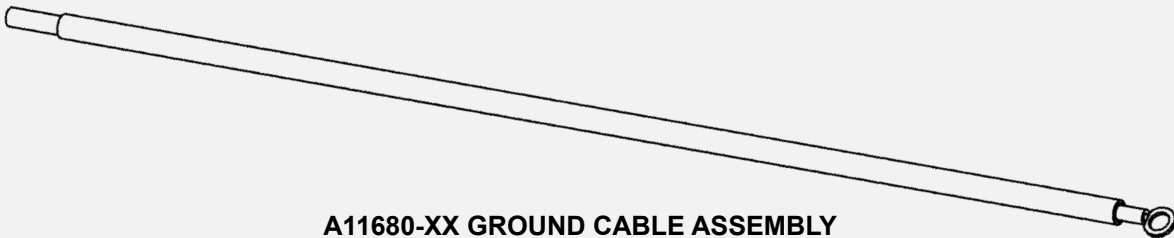

A11680-XX GROUND CABLE ASSEMBLY

TABLE "G" - GROUND CABLE

Dash No.	Part Number	Description
0	A11680-10	CABLE, GROUND (10 FT.)
1	A11680-25	CABLE, GROUND (25 FT.)
2	A11680-50	CABLE, GROUND (50 FT.)
3	A11680-75	CABLE, GROUND (75 FT.)
4	A11680-100	CABLE, GROUND (100 FT.)

A13853 CONFIGURATION DRAWING

INTRODUCTION

APPLICATOR DESCRIPTION

The RMA-550 is an automatic robot mounted rotary atomizer capable of spraying solvent-borne coatings electrostatically or non-electrostatically. It incorporates the latest in high speed spindle technology, bell cup and shape air design to provide the best in atomization and pattern control. The bell cups are designed for durability using the best materials available. All wetted components are designed to offer the maximum in wear and chemical resistance. The atomizer incorporates an integrated internal cascade capable of applying 90,000 VDC directly to the coating materials.

FEATURES

Features which make the RMA-550 advantageous for use in electrostatic applications include:

- **F**actory **M**utual Listed. Limited energy is available to prevent ignition of flammable air/solvent mixtures.
- True dual purge capability. Spray one color while cleaning the other paint line with no loss of tip voltage.
- Assembly components made of durable engineered resin material for optimum mechanical strength and solvent resistance.
- Heavy duty design insures excellent service life even when subjected to the quick motions of robotic applications.
- Proven long life turbine motor capable of speeds up to 55 krpm. (See "Specifications" in the "Introduction" section of this manual for bell cup speed ratings.)
- Serrated bell cup is available for application flexibility and color match.
- Aerodynamic design for ease of cleaning external surfaces.
- 60° angled body provides more maneuverability and facilitates robotic programming.
- An extended length robot adapter is available. This option gives greater flexibility and extended tubing life.
- Small light weight package allows better maneuverability in tight areas.
- Negligible maintenance down time. With the quick disconnect feature, an atomizer can be changed in less than 2 minutes for off-line maintenance.
- The easily removable front and rear shrouds, turbine assembly and the internally mounted fluid valves make off-line maintenance more efficient and economical. A split shroud is available for easy access to internal components while still mounted on the robot.
- Fast color changes are achieved using center feed fluid delivery and the fluid valves provide for simultaneous paint push while solvent washes the feed tube and bell cup interior.
- Internal and external bell cup wash is quick and efficient. Solvent is controlled at the feed tube with an internally mounted solvent valve. Externally mounted regulators control the flow.
- On the single purge valve manifold, cup wash solvent and air valves are integrated in the manifold for a quick interior and exterior cup wash. On the dual purge version valve manifold, remote solvent and air valve provides a quick and efficient cup wash.
- Used with the MicroPak 2e single bell controller.
- Less waste to the spray booth, with the dump valve located internally next to the feed tube.
- No external high voltage cable. The internally mounted high voltage cascade requires only low voltage control wiring.
- **The Ransburg MicroPak 2e Single Bell Controller** is a free standing unit which provides voltage to a remotely located cascade and closed loop speed control for Ransburg atomizer units.
- Various adapter plates available to match most robotic mounting configurations.
- Direct charging of fluid (solvent borne paint) promotes high transfer efficiency.

- Large range of fluid tip sizes available.
- Fittingless tubing bundle, more flexibility in the robot wrist and easier to repair damaged tubes.
- Valve manifold can be ordered as a single or dual purge version.

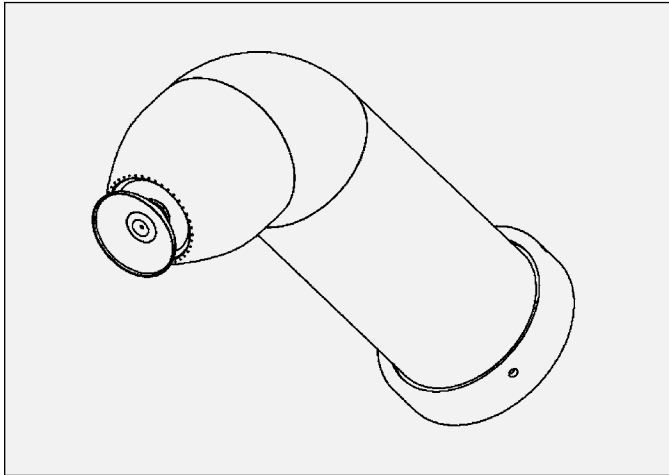

Figure 1: RMA-550 Rotary Atomizer.

GENERAL DESCRIPTION

RMA-550 FM System

The Ransburg RMA-550 is a high speed rotary atomizer system designed to meet agency safety requirements for safer operation. This system is incapable of releasing sufficient electrical or thermal energy during normal operating conditions to cause ignition of specific hazardous materials in their most easily ignited concentrations in air (See NFPA-33 Regulations). The RMA-550 provides electrostatic application with excellent atomization and transfer efficiency for a wide variety of coating materials.

WARNING

► The RMA-550 System is designed to provide safer operation in accordance with NFPA-33, when used and maintained in a proper manner. Equipment cleanliness and proper routine maintenance are required to maintain safe operating conditions.

Bell Cup Assembly

The plastic bell cup is coated with a proprietary resistance material for transfer of electrostatic charge to the atomized fluid.

Air Bearing Turbine Assembly

The air bearing turbine assembly with bell cup is mounted to the air manifold assembly with a turbine retaining ring.

Air Manifold Assembly

The atomizer extension is angled at 60° for robot applications. The fluid feed tube and fiber optic turbine speed emitter are threaded into the front of the manifold. The turbine, fluid, and air manifolds are separated from the bell plate assembly by five support rods. Nested between the manifolds and the bell plate is the high voltage cascade. An optional extended version is available to promote atomizer cleanliness and hard to reach areas.

Bell Plate Assembly

The bell plate assembly is designed to be at ground potential when mounted to the robot plate component within the tubing bundle assembly. The air and fluid ports are compactly oriented for use in robotic applications. The air supplies are ported through the five support rods directly to the air manifold assembly. On the exterior side of the bell plate, the ports are provided with O-ring seals so that the atomizer can be quickly mated and secured to the robot plate.

Robot Plate

The robot plate is a component of the tubing bundle assembly and intended to be permanently mounted to the robot. A wrist adapter is also available, which matches the robot's mounting configuration. The incoming air lines, fluid lines, low voltage cable, and fiber optic cable are connected to the fittings provided at the robot plate. The bell plate of the atomizer assembly is secured to the robot plate with a threaded retaining ring.

Valve Manifold

This manifold can be configured for either single or dual purge application. The dual purge can allow two colors to be loaded at one time.

Power Supply and Controls

The high voltage cascade is located inside the applicator and is controlled by the MicroPak 2e. The low voltage output of the MicroPak 2e is multiplied by the internal cascade to the high voltage level required. This eliminates the need for a high voltage cable. A low voltage cable interconnects the cascade and MicroPak 2e. The MicroPak 2e and the applicator's internal cascade will produce voltages up to 90,000 VDC.

The MicroPak 2e is designed to electronically limit current to provide safe operation in a spray booth. The voltage and current draw of the atomizer are continuously displayed on the MicroPak 2e panel. Voltage and over-current limits are adjustable to 90 microamps on the front of the MicroPak 2e. MicroPak 2e is programmed to detect over-current and cable faults and shut down.

NOTE

- ▶ User to display AER0075-05 placard. Place in an area visible to all operators.

SPECIFICATIONS

Electrical:

Power Supply Type:	MicroPak 2e
Charging Method:	Direct
Output Voltage:	30-90 kV Variable (90 kV Maximum)
Output Current:	90 μ A
Turbine Speed Control:	Multi-Function Board included in the MicroPak 2e Controller, Maximum 55,000 rpm
Part Spray Ability:	Determine sprayability of part to be coated using Test Equipment (76652) (Paint Conductivity Meter)

Mechanical:

Length:	(See RMA-550 Tool Point, Center of Gravity, and Envelope Dimension (Single and Dual Flex) figure in the "Introduction" section.)
Diameter:	(See RMA-550 Tool Point, Center of Gravity, and Envelope Dimensions (Single and Dual Flex) figure in the "Introduction" section.)
Approximate Weight Atomizer Only:	11.0 lbs. (5.0 Kg.)
Total Payload with Robot Plate & Adapter:	13.7 lbs. (6.2 Kg.)
Turbine Type:	Air Bearing Impulse Drive
Turbine Air Supply:	Variable (See "Pressure Flow Data Charts" in the "Introduction" section.)
Maximum/Minimum Turbine Speed:	Continuous 55K rpm max. /20K rpm min.
Maximum Angular Velocity for Turbine (Robot Motion):	250°/sec.
Tubing Bundle Max. Rotation:	450° in Either Direction
Bearing Air Supply at the Applicator: (Nominal):	90 psig (\pm 10 psi) (621 kPa \pm 69 kPa) 2.9 SCFM (82 slpm)
Shaping Air #1 (SAI) Supply:	Variable (See "Pressure Flow Data Charts" in the "Introduction" section)
Shaping Air #2 (SAO) Supply:	Variable (See "Pressure Flow Data Charts" in the "Introduction" section)
Brake Air Supply (Nominal):	60-100 psig (414-689 kPa)
Maximum Fluid Pressure Supply:	
Paint:	150 psi (1035 kPa)
Solvent:	150 psi (1035 kPa)
Maximum Air Pressure:	100 psi (689 kPa)

(Continued on next page)

Mechanical (Cont.):

Fluid Flow Rate:	25-500 cc/min. (See exclusion below)
Bell Cup Cleaning Time (Internal/External):	2.7 sec. (approx.)
Color Change Time:	Dependent on system configuration, fluid pressures, fluid viscosity, fluid line lengths, etc.
Speed Readout:	Magnetic pick-up, unidirectional fiber optic transmission
Atomizer Replacement Time:	Less than 5 min.
Bell Cup Replacement Time:	Less than 2 min.
Minimum Control Equipment Requirements:	(Versions listed or higher)
MicroPak 2e	V1.1.00
Air Heater Recommendation:	An Air Heater is recommended for the turbine air supply. See Air Heater and filtration recommendation later in this manual

* Although this turbine assembly is capable of operating at continuous speeds up to 55,000 rpm, nearly all high quality finishes can be achieved within our recommended operating range of 20,000 to 55,000 rpm, based on experience with a wide variety of materials and various markets. Operating above this range is for highly specialized applications, and may reduce efficiency and equipment life. Contact your Ransburg representative for additional information as required.

** Specifications and ratings based on testing at sea level standard conditions.

IMPORTANT NUMBERS

Record these numbers in a log book for future reference. The last digits of the Atomizer serial number are also the Turbine serial numbers.

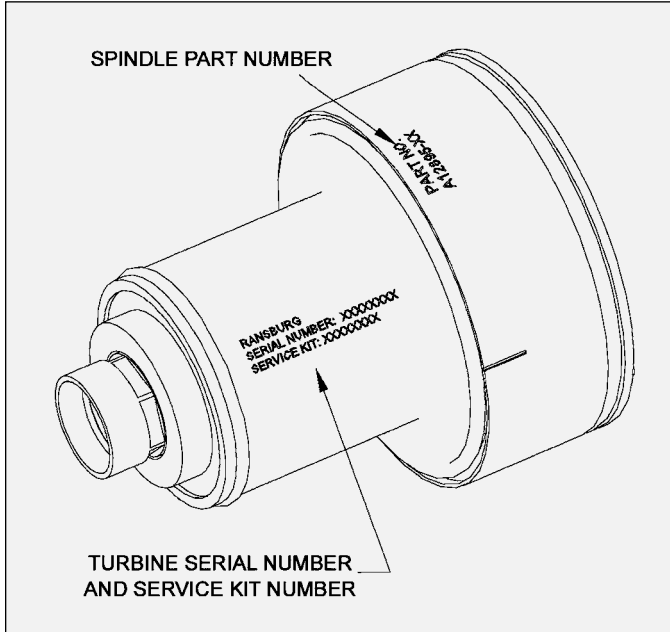

Turbine Serial Number

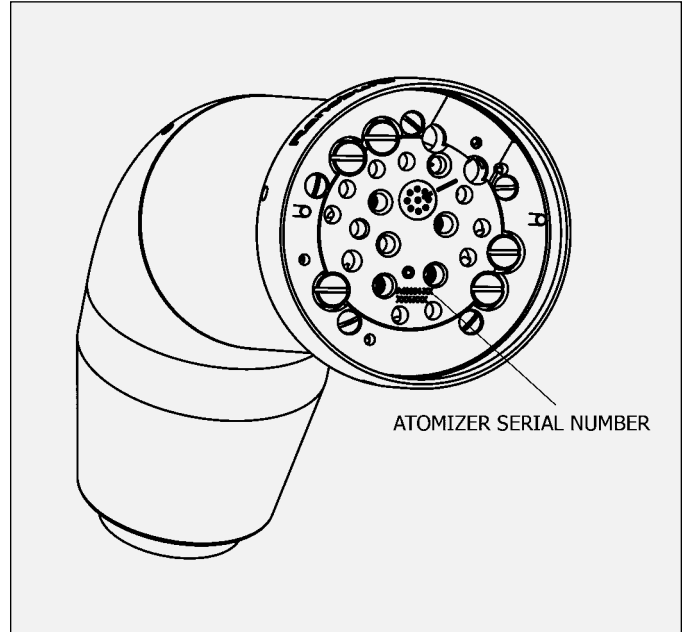

Atomizer Serial Number

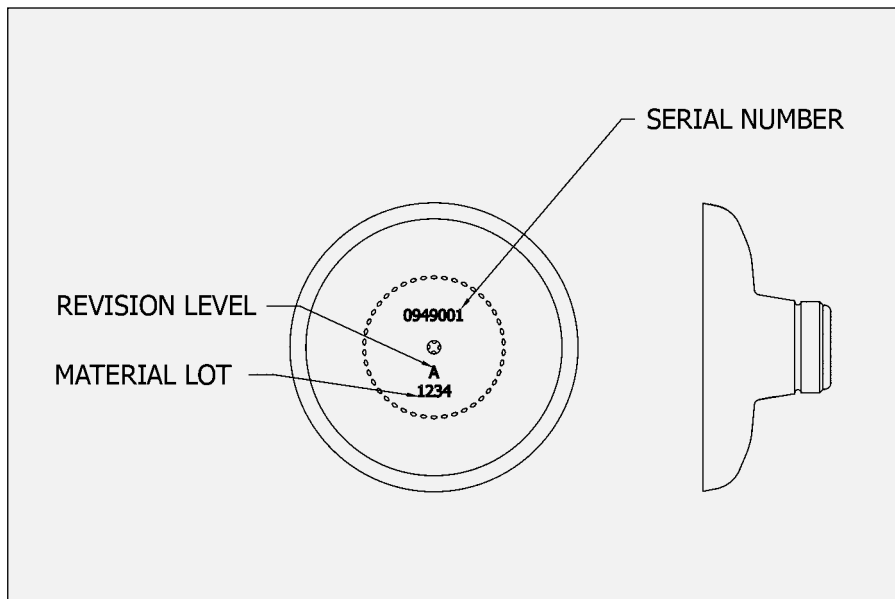

Bell Cup Serial Number and Information

GRAPHS

Graphical information provided for reference only for all charts. Unless otherwise specified, all pressure data shown was measured 12-inches (305mm) behind the applicator.

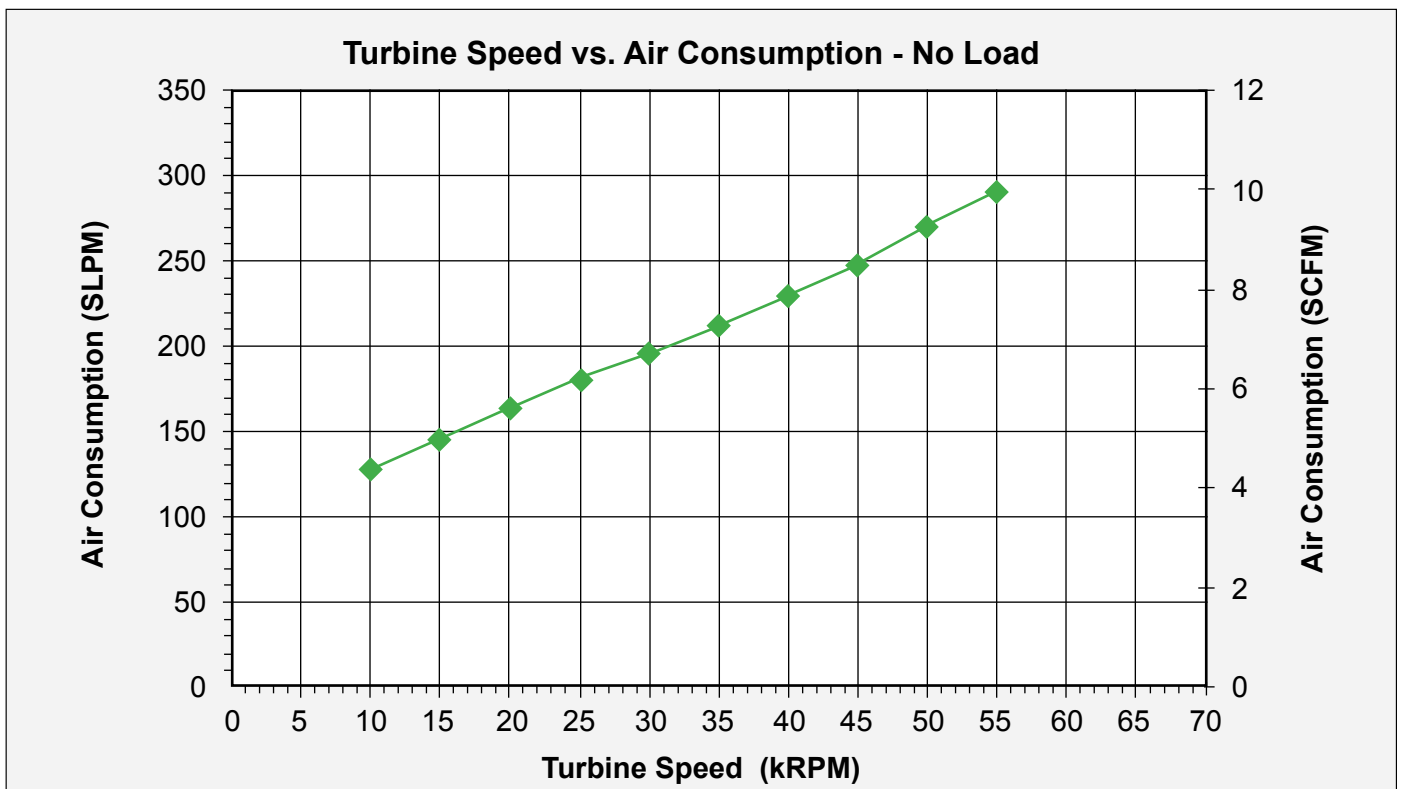
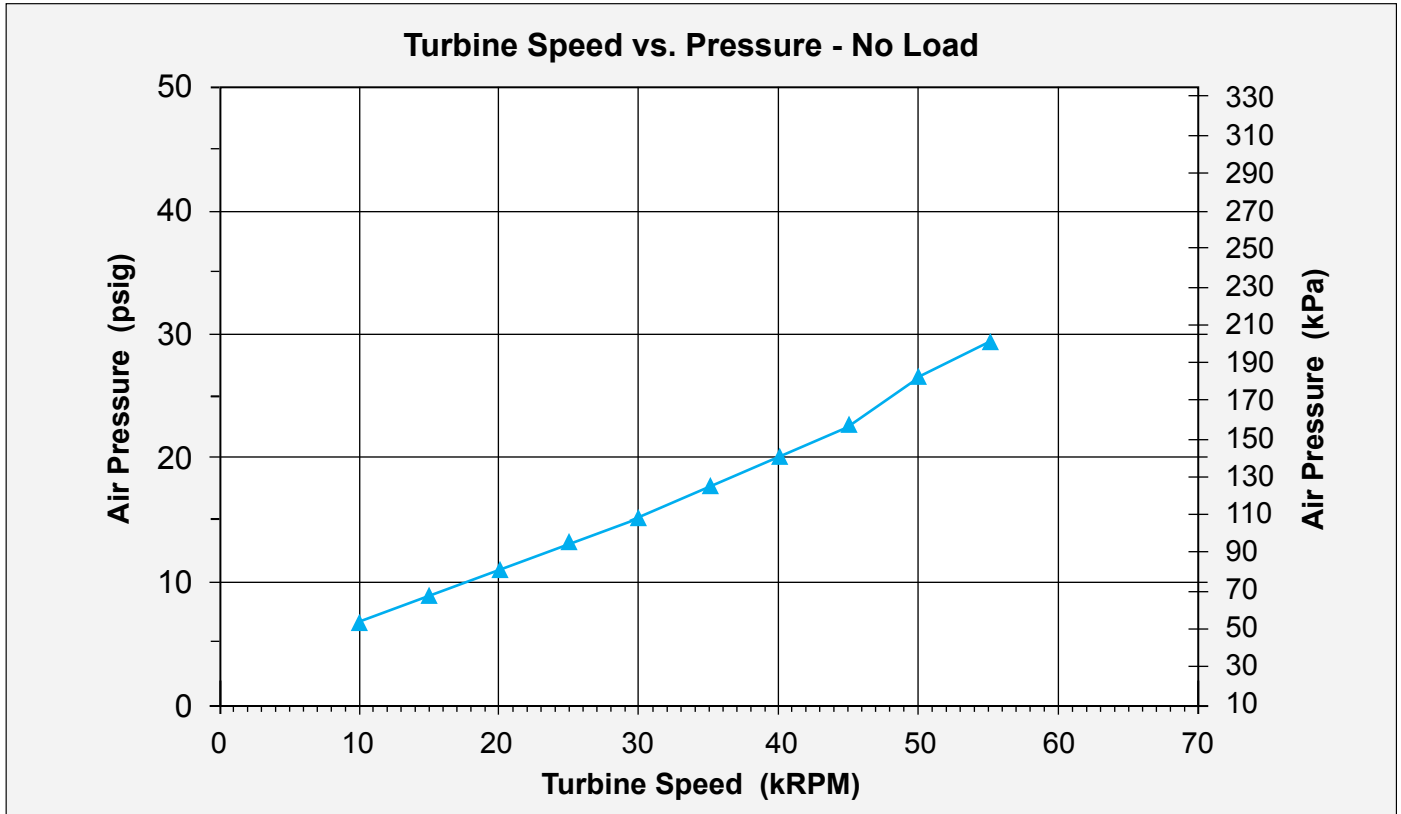

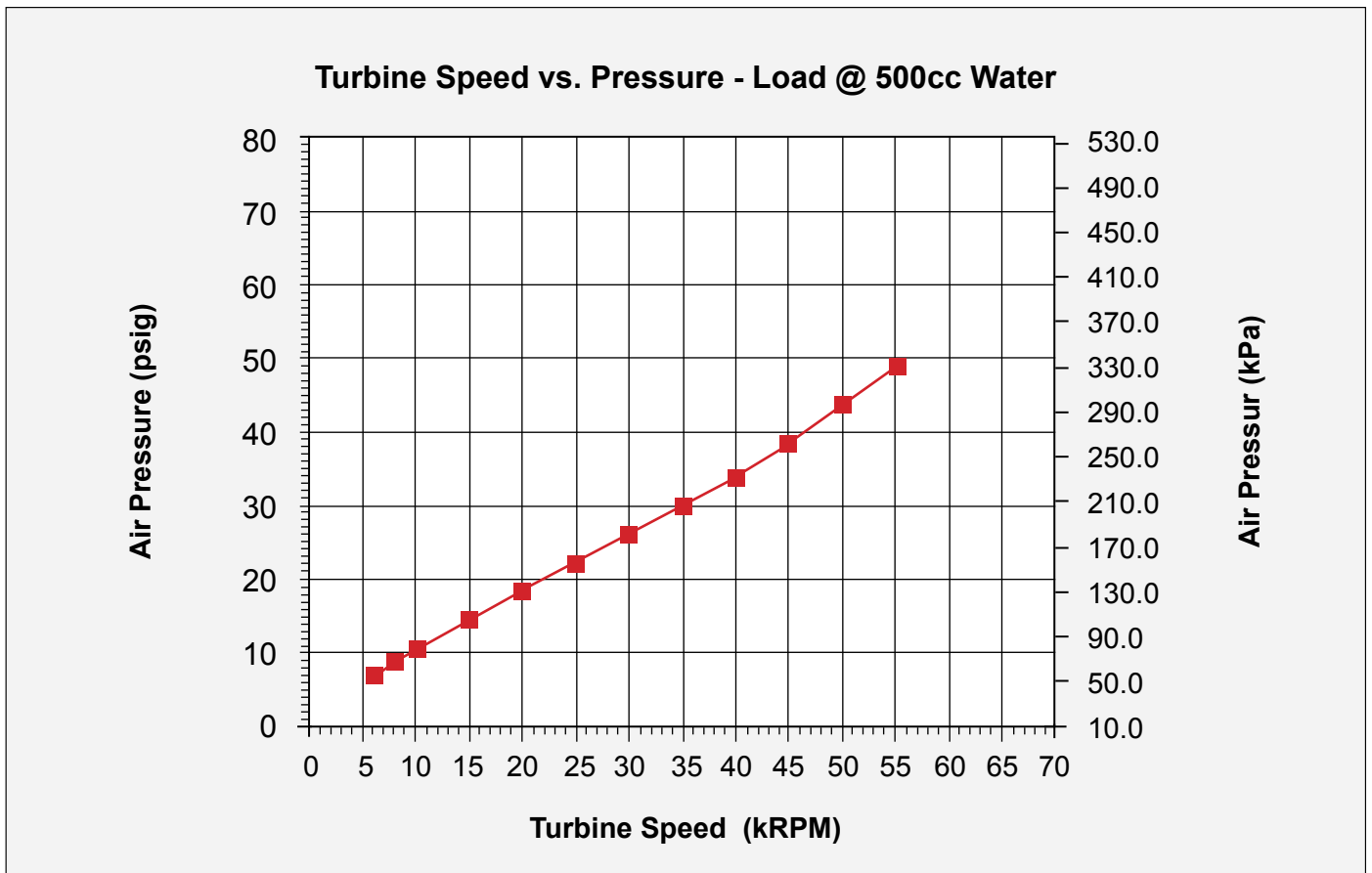
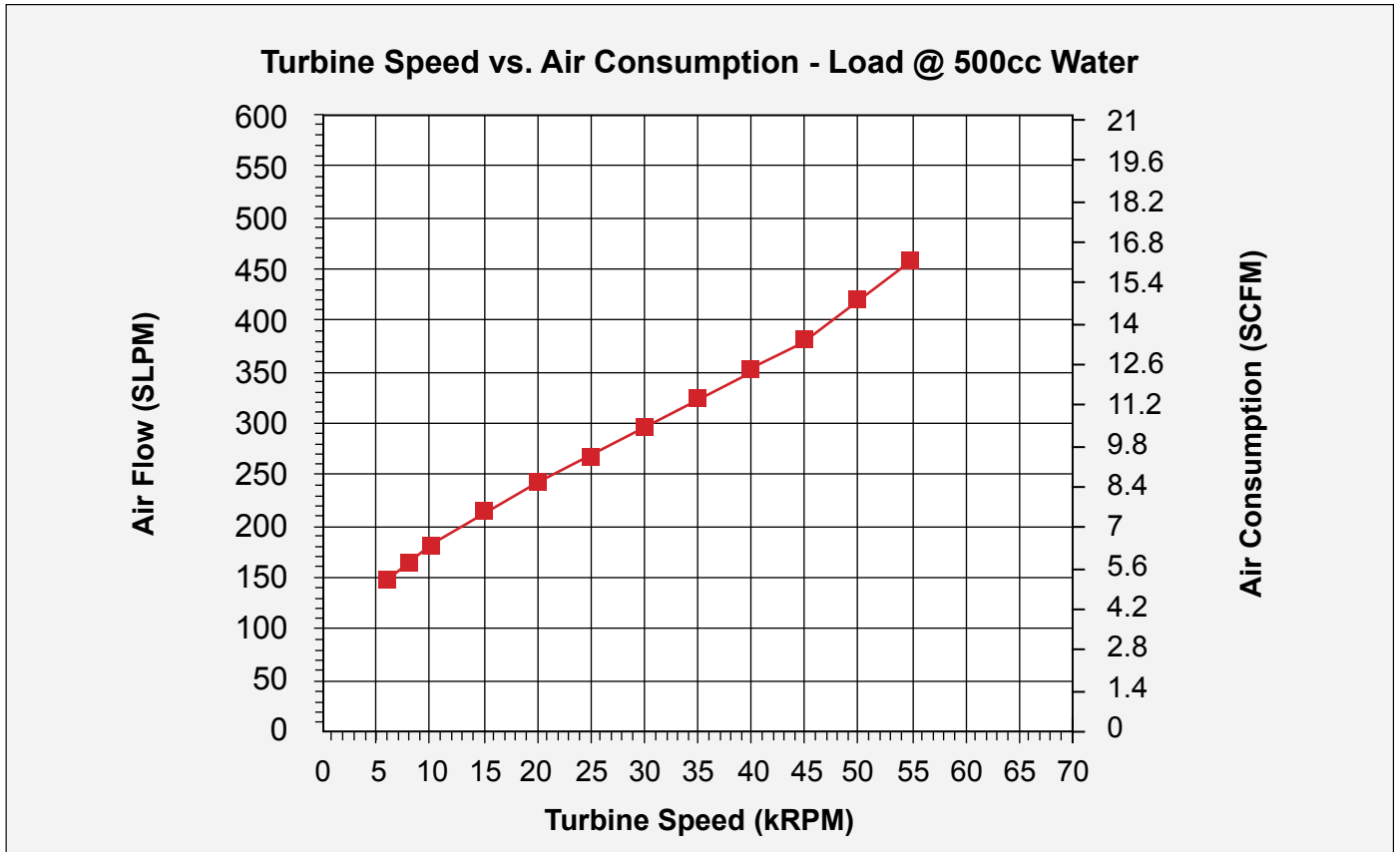

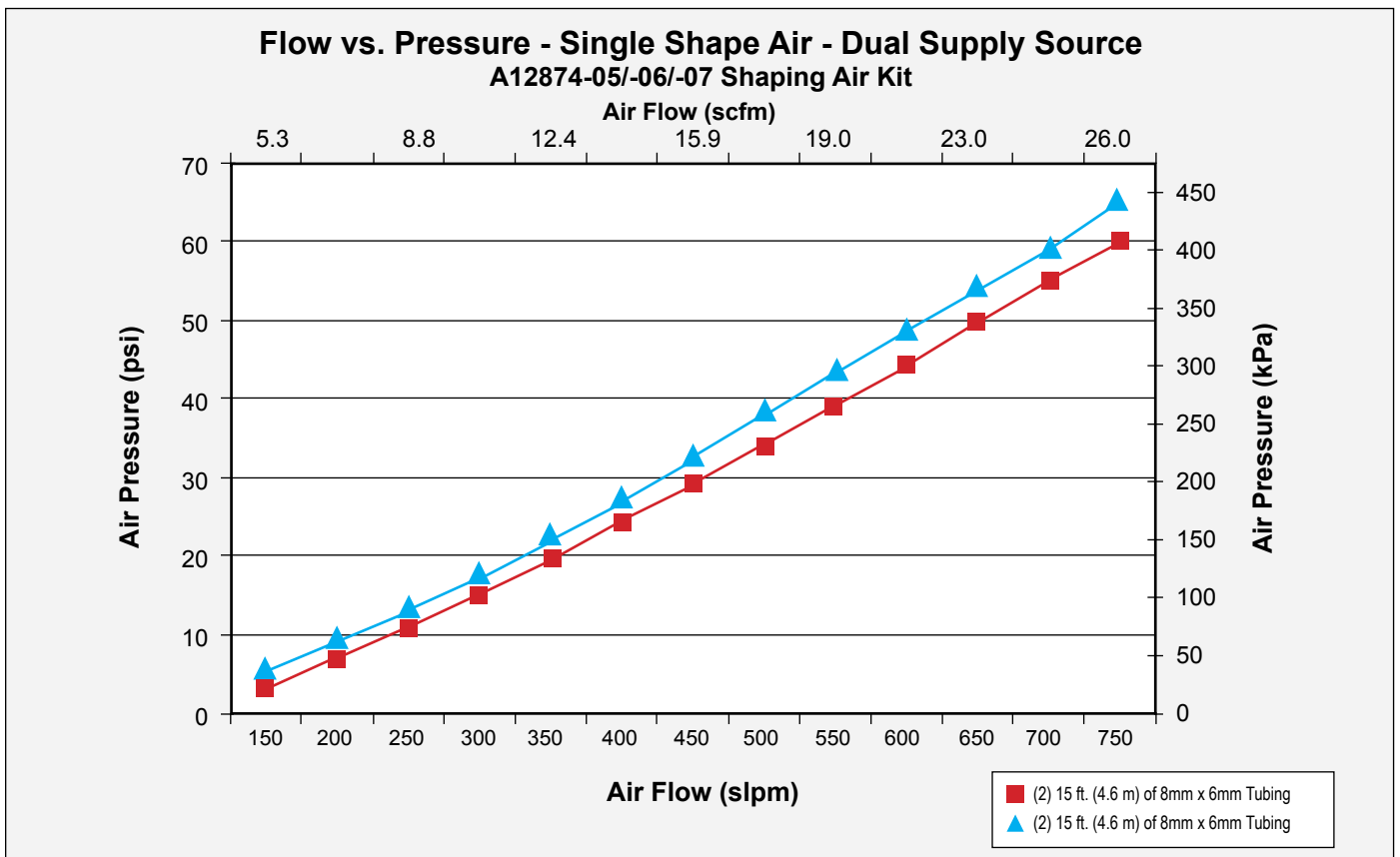
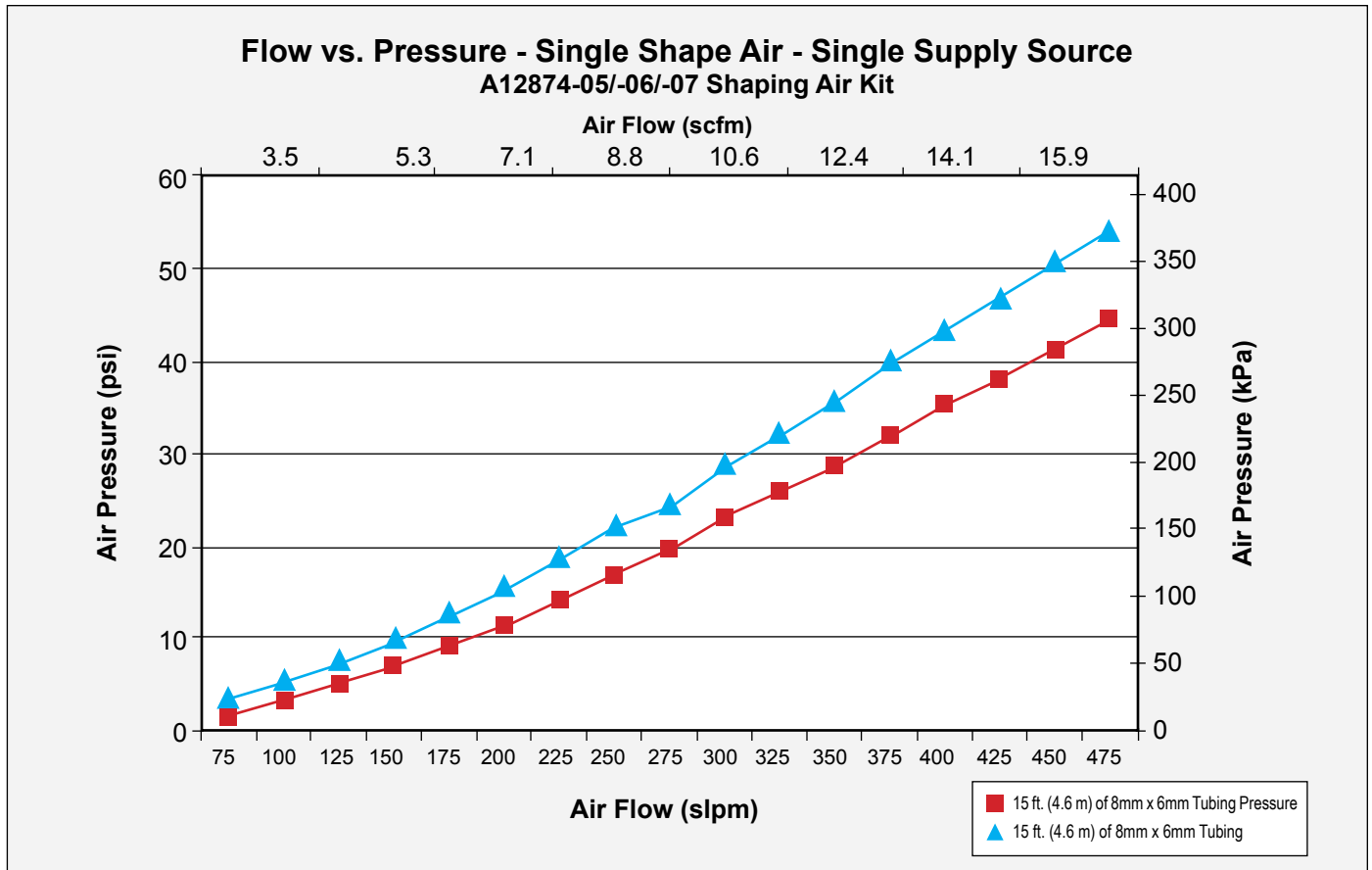

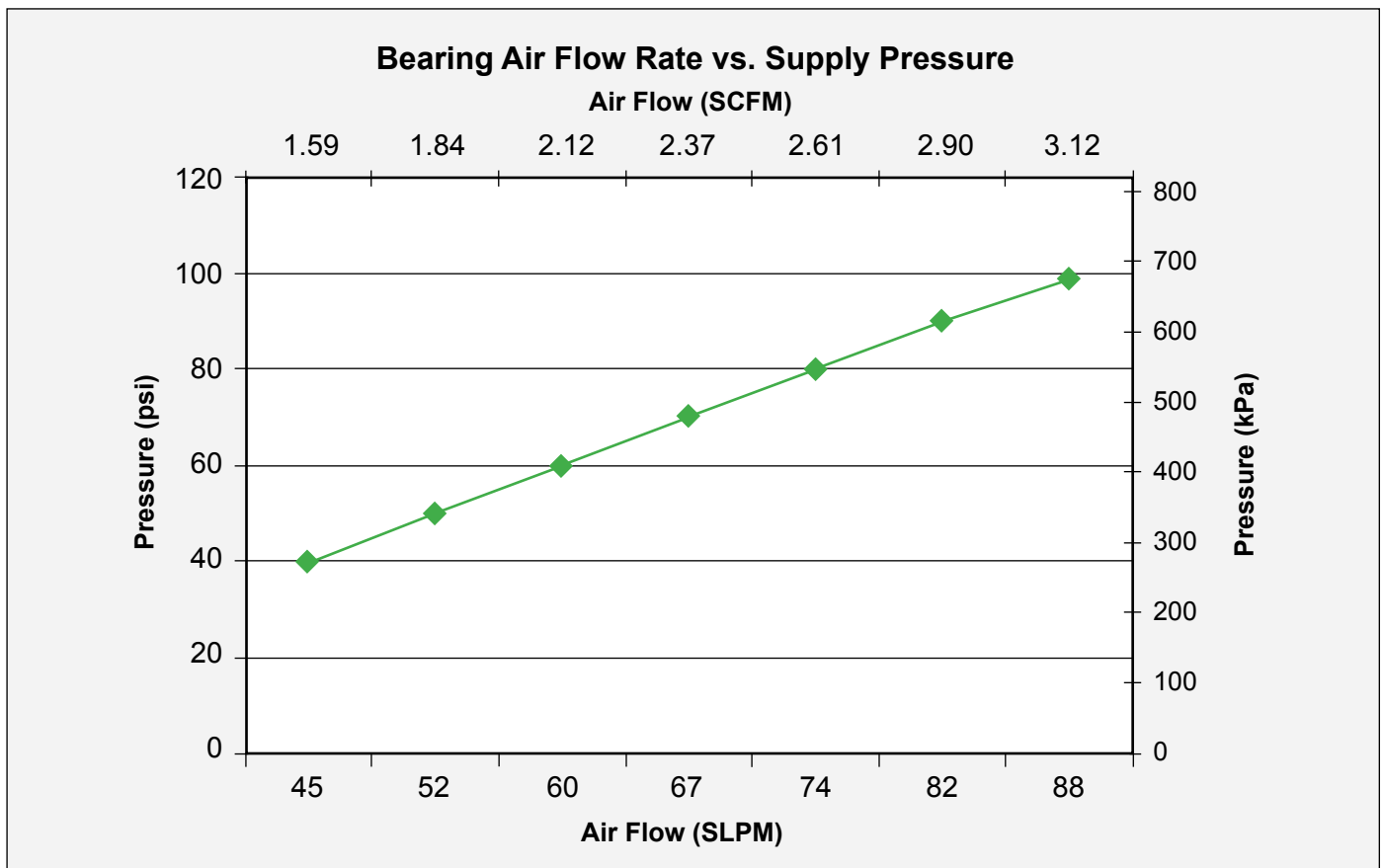
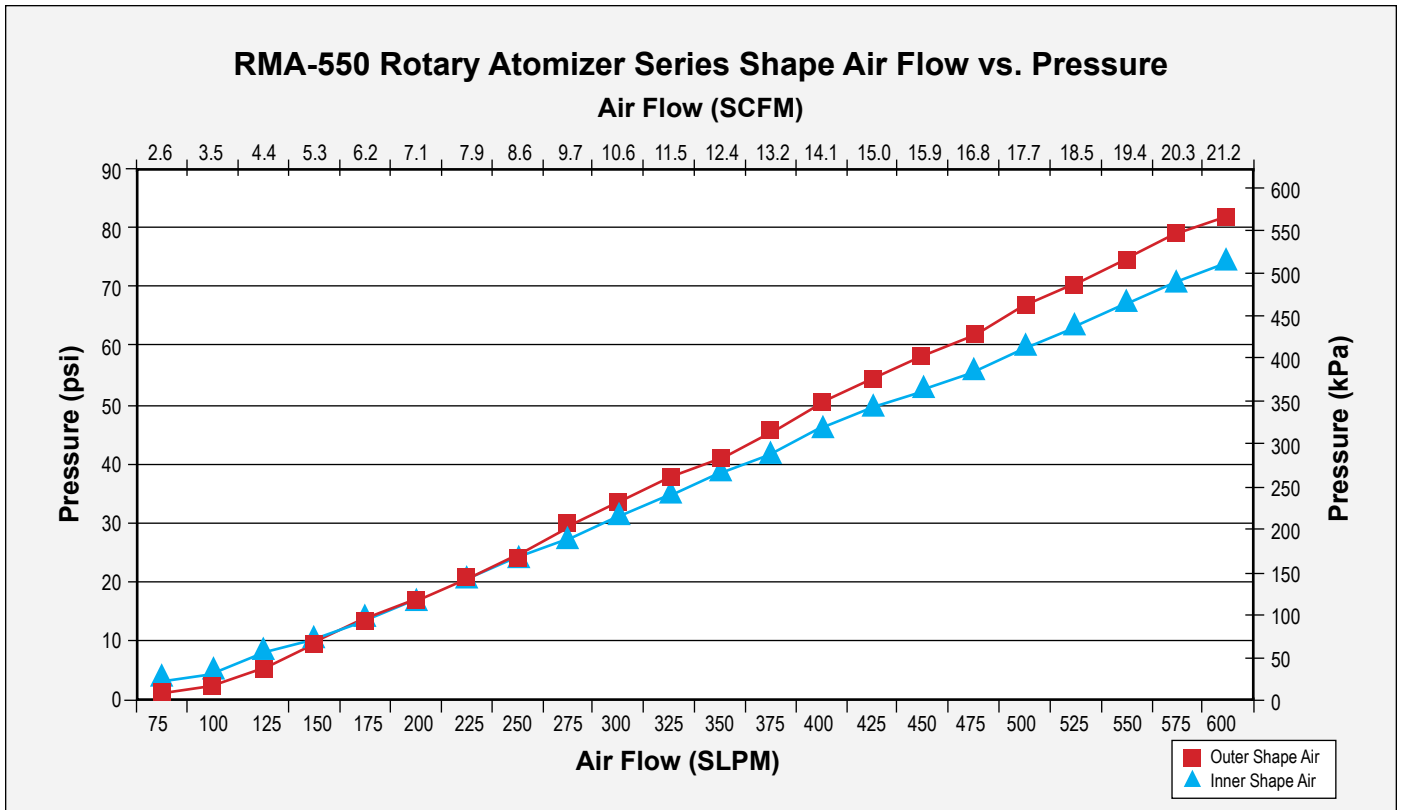

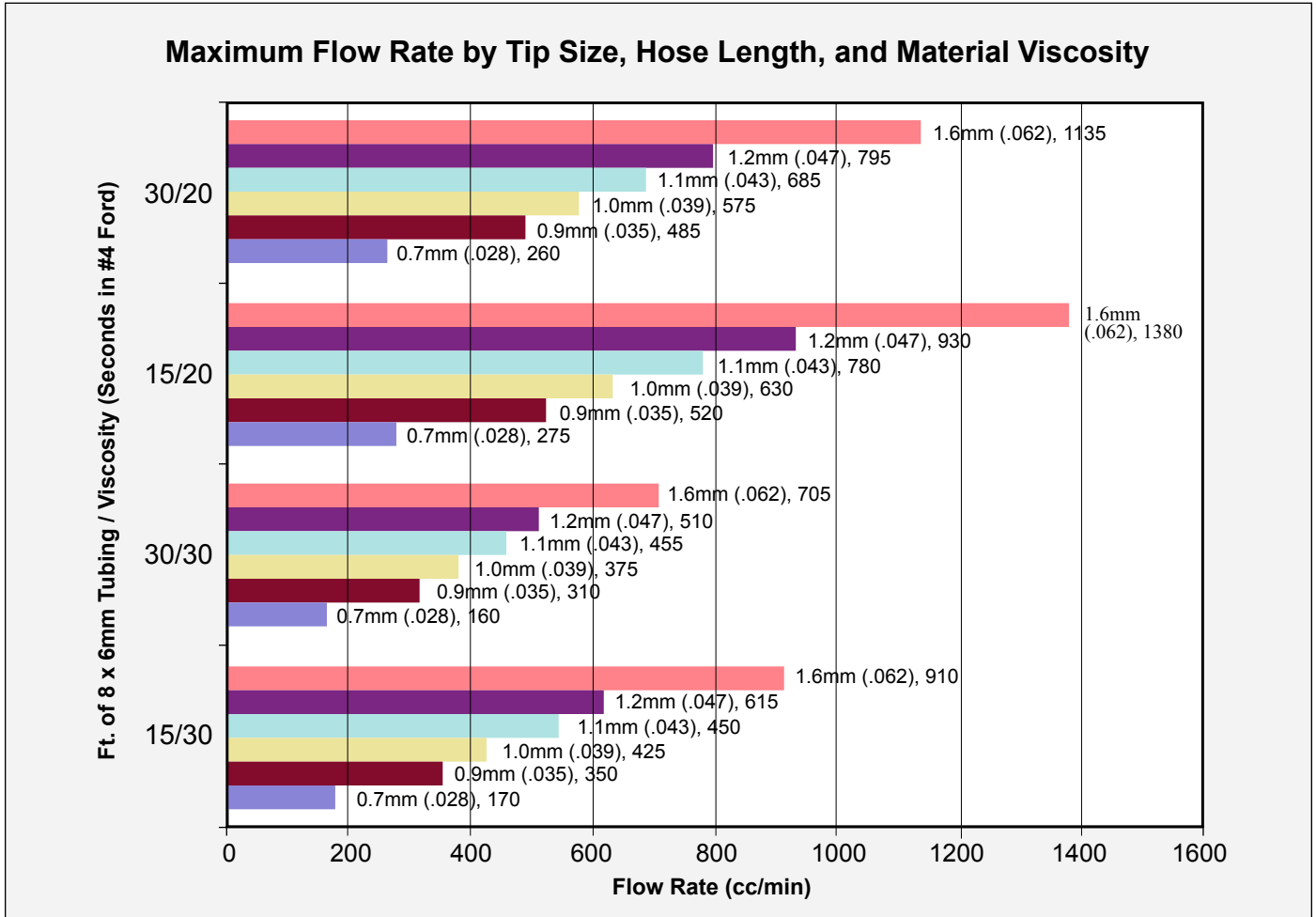

RMA-550 TOOL CENTER POINT DIMENSIONS (Single Shape Air)

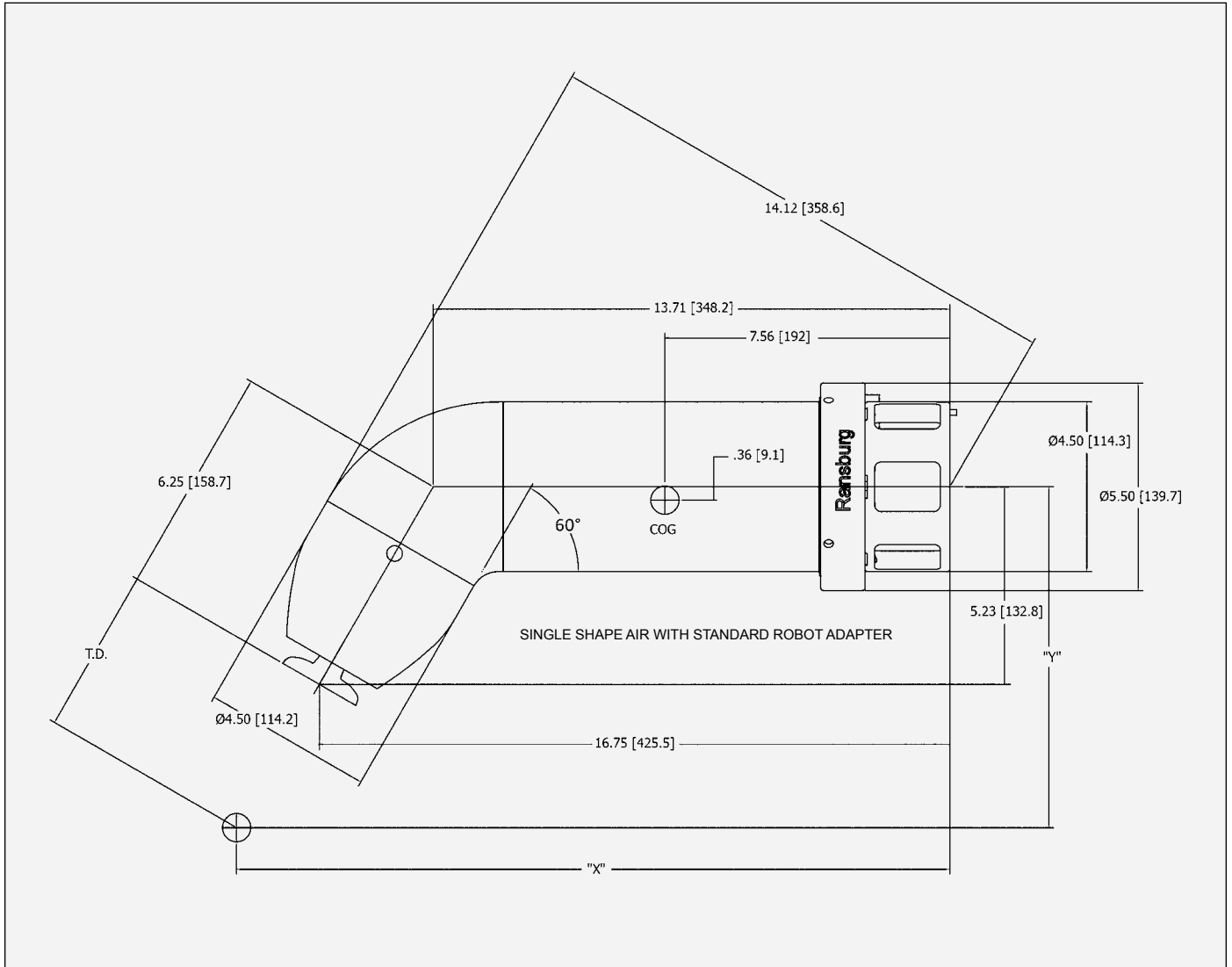

SINGLE SHAPE AIR WITH STANDARD ROBOT ADAPTER		
TD	X	Y
6-Inches (152mm)	19.73-Inches (501.1mm)	10.44-Inches (257.6mm)
8-Inches (203mm)	20.73-Inches (526.5mm)	12.17-Inches (309.1mm)
10-Inches (254mm)	21.73-Inches (551.9mm)	13.89-Inches (352.8mm)
12-Inches (305mm)	22.73-Inches (577.3mm)	15.63-Inches (397mm)

RMA-550 TOOL CENTER POINT DIMENSIONS (Dual Shape Air)

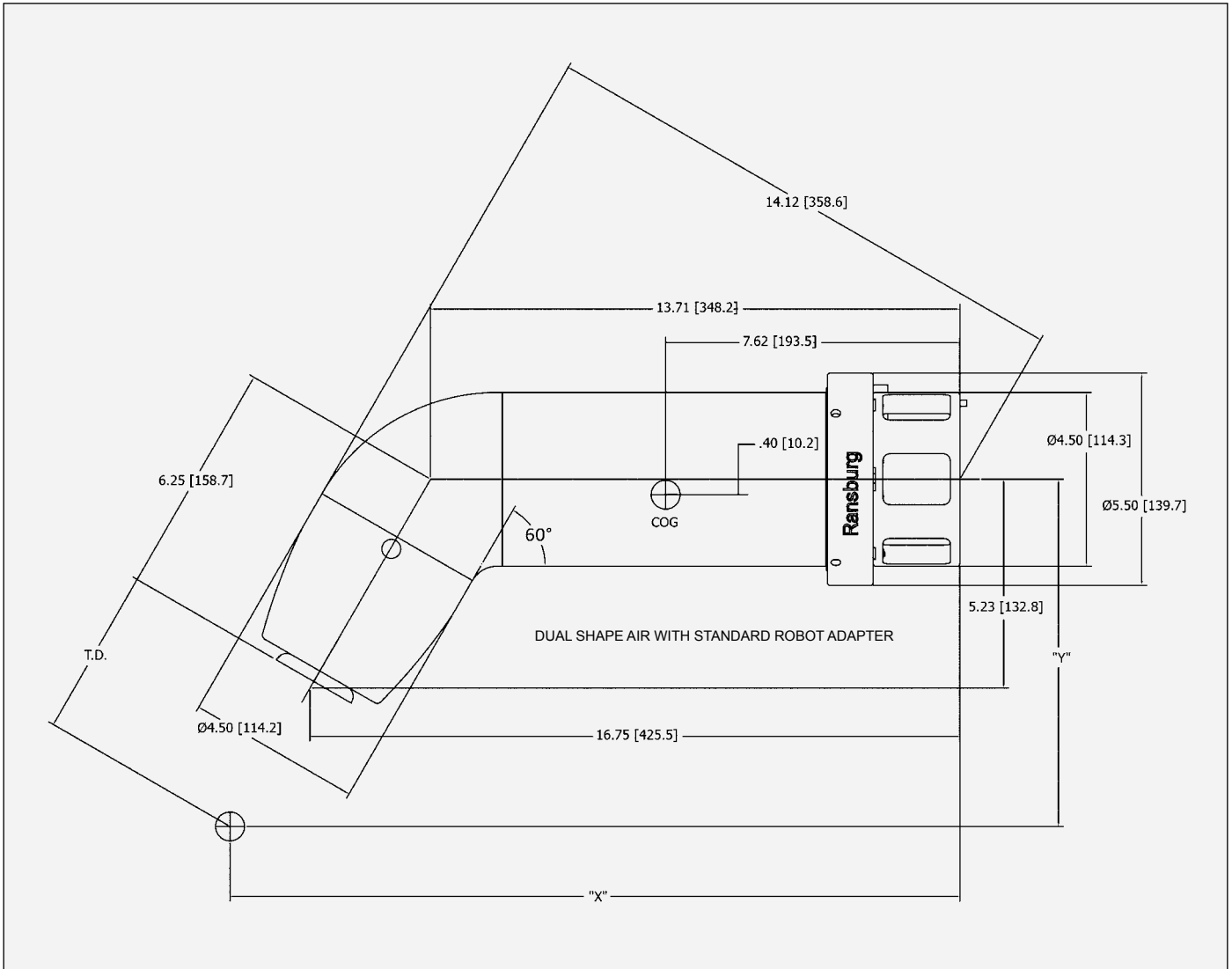

DUAL SHAPE AIR WITH STANDARD ROBOT ADAPTER

TD	X	Y
6-Inches (152mm)	19.73-Inches (501.1mm)	10.44-Inches (257.6mm)
8-Inches (203mm)	20.73-Inches (526.5mm)	12.17-Inches (309.1mm)
10-Inches (254mm)	21.73-Inches (551.9mm)	13.89-Inches (352.8mm)
12-Inches (305mm)	22.73-Inches (577.3mm)	15.63-Inches (397mm)

RMA-550 TOOL CENTER POINT DIMENSIONS

(Single Shape Air with Extended Robot Adapter)

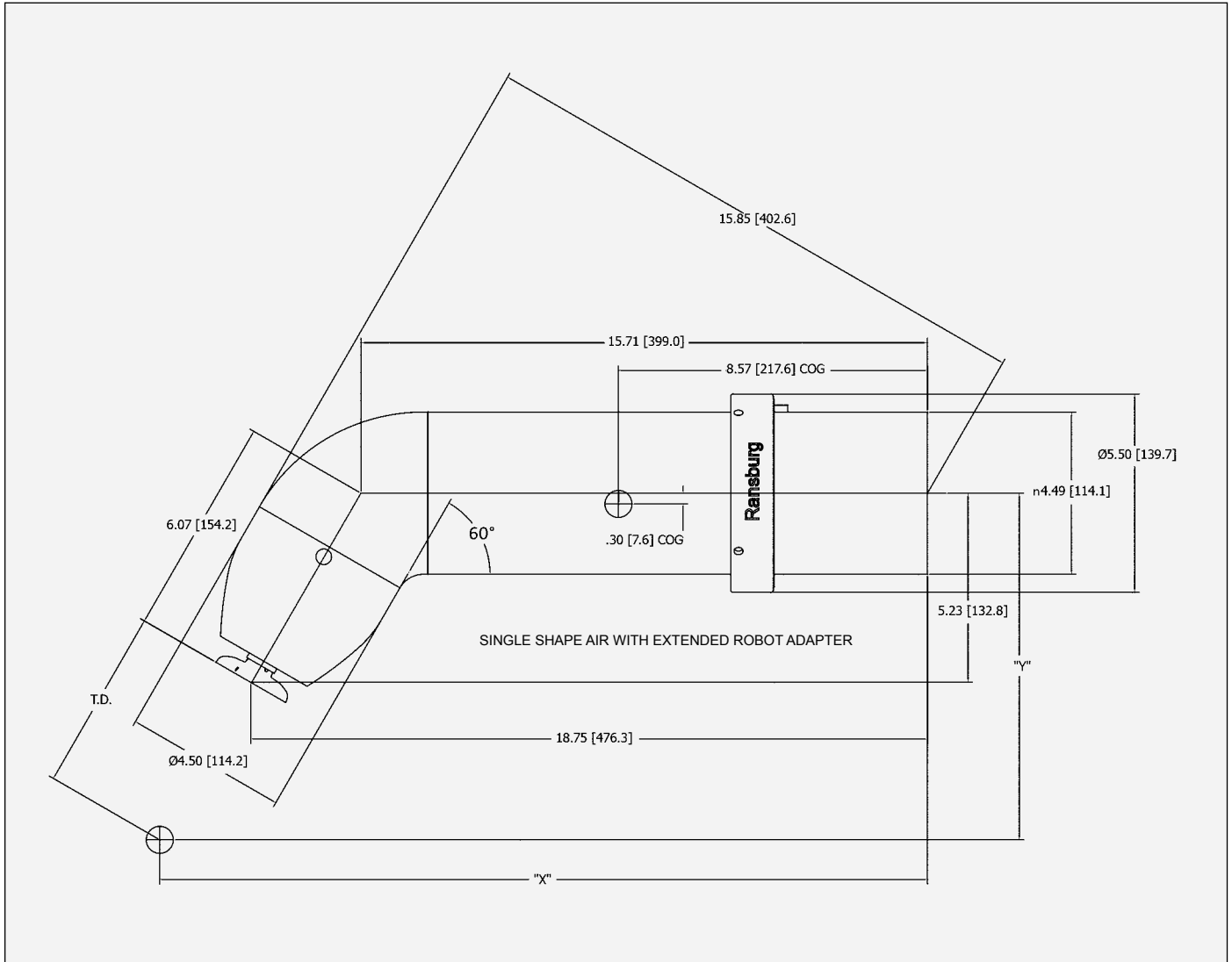

SINGLE SHAPE AIR WITH EXTENDED ROBOT ADAPTER		
TD	X	Y
6-Inches (152mm)	21.73-Inches (501.1mm)	10.44-Inches (257.6mm)
8-Inches (203mm)	22.73-Inches (526.5mm)	12.17-Inches (309.1mm)
10-Inches (254mm)	23.73-Inches (551.9mm)	13.89-Inches (352.8mm)
12-Inches (305mm)	24.73-Inches (577.3mm)	15.63-Inches (397mm)

RMA-550 TOOL CENTER POINT DIMENSIONS (Dual Shape Air with Extended Robot Adapter)

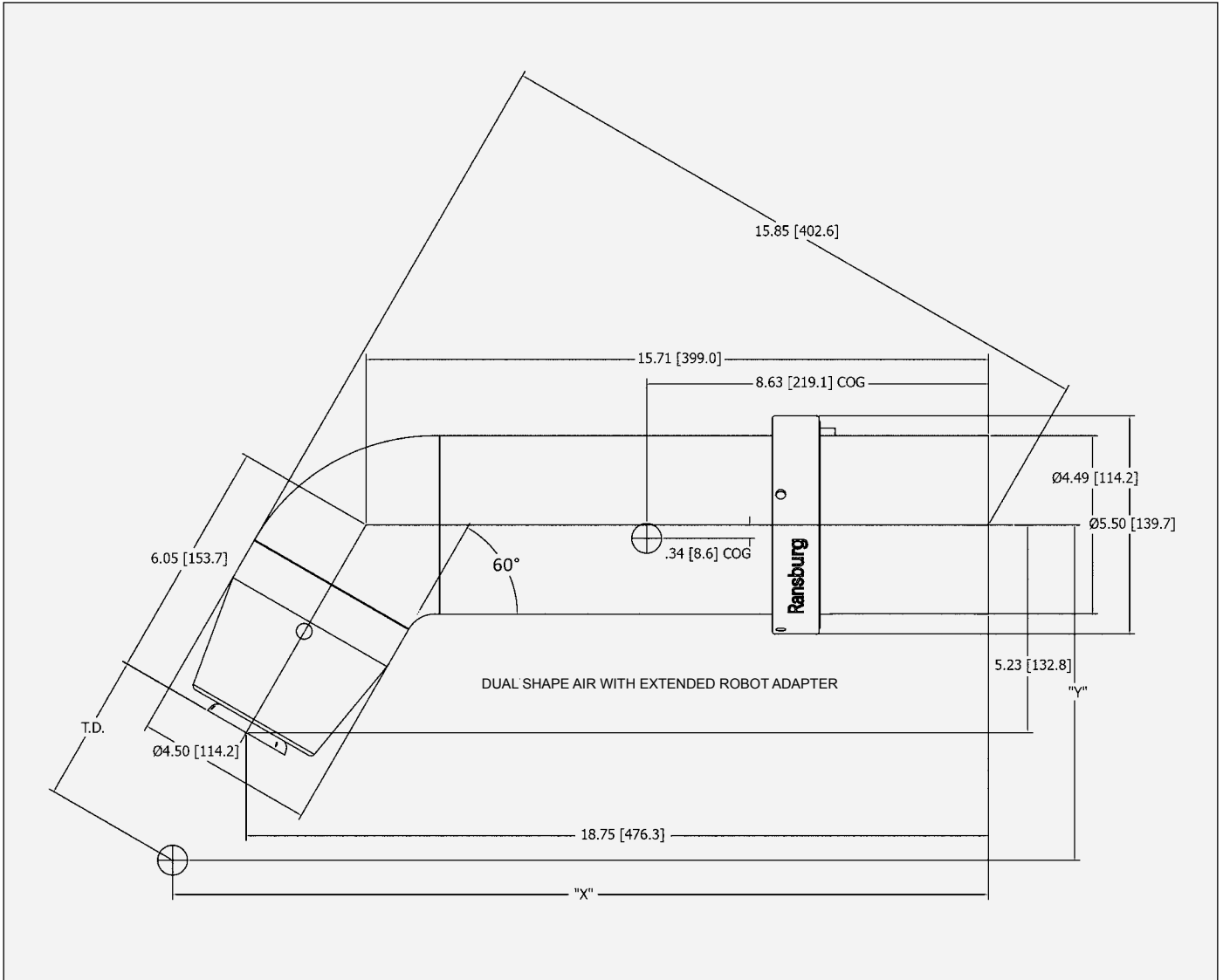

DUAL SHAPE AIR WITH EXTENDED ROBOT ADAPTER		
TD	X	Y
6-Inches (152mm)	21.73-Inches (501.1mm)	10.44-Inches (257.6mm)
8-Inches (203mm)	22.73-Inches (526.5mm)	12.17-Inches (309.1mm)
10-Inches (254mm)	23.73-Inches (551.9mm)	13.89-Inches (352.8mm)
12-Inches (305mm)	24.73-Inches (577.3mm)	15.63-Inches (397mm)

CIRCUIT SCHEMATIC (DUAL PURGE)

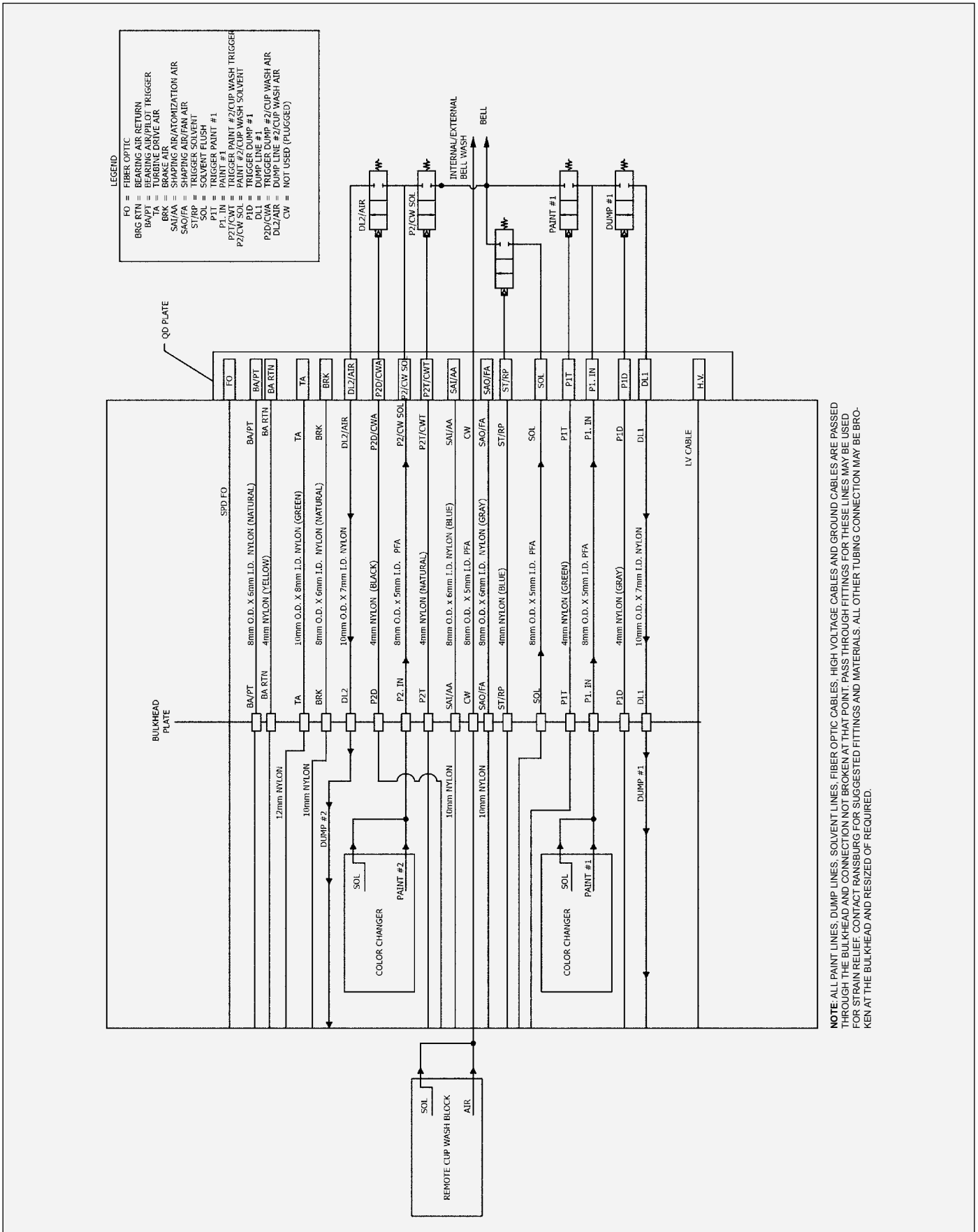

VALVE SCHEMATIC

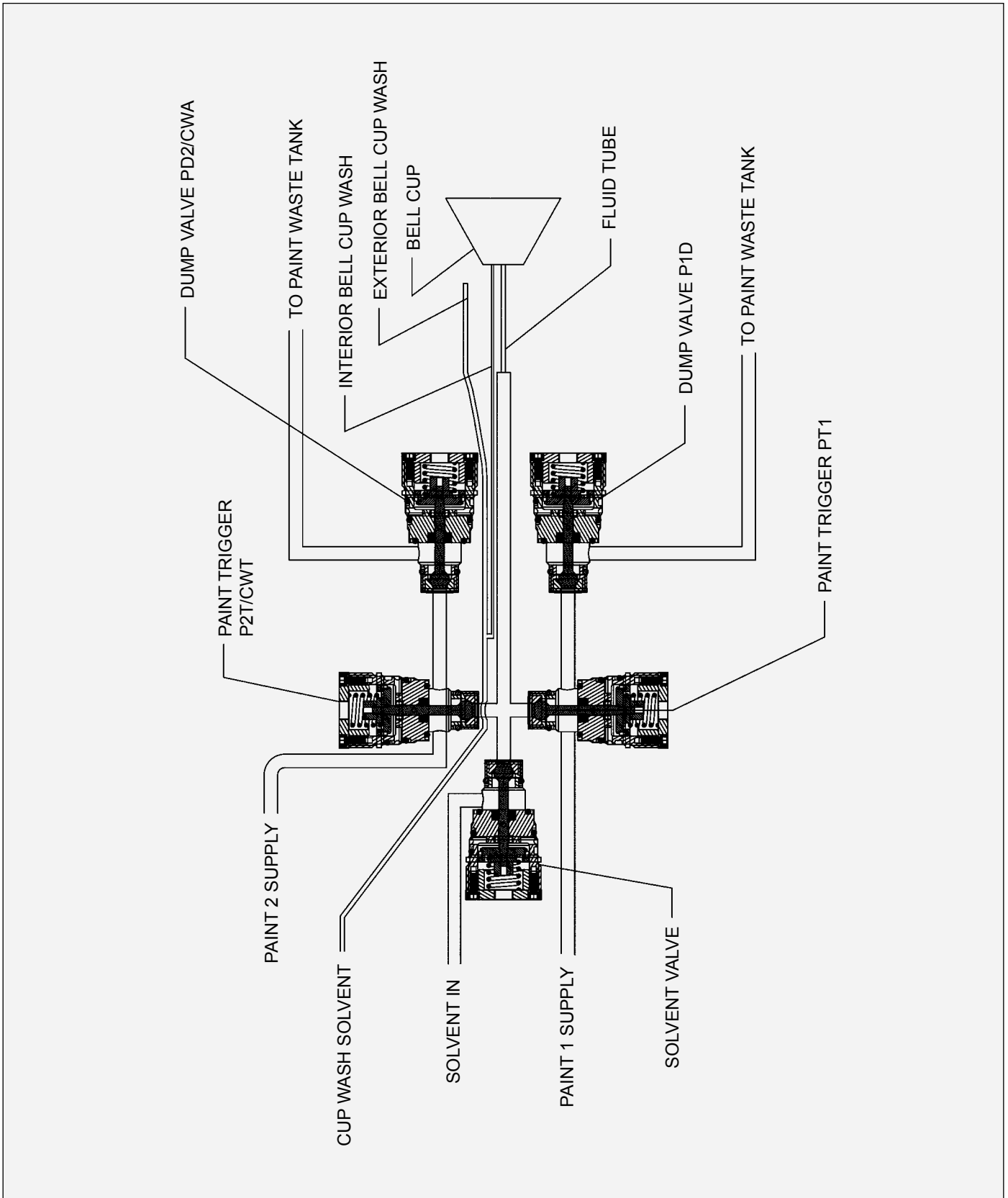

Dual Purge Manifold Version Schematic

CIRCUIT SCHEMATIC (SINGLE PURGE)

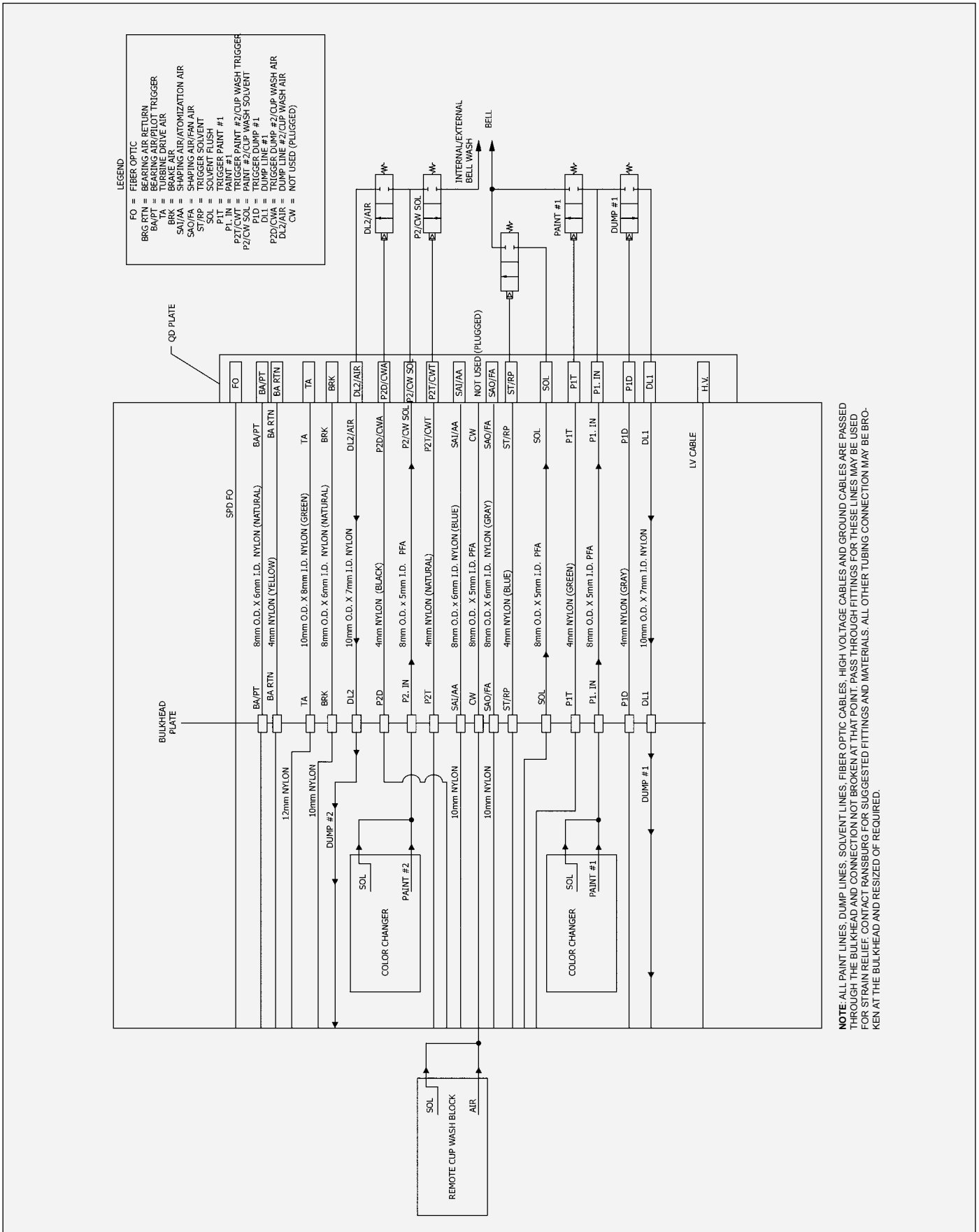

VALVE SCHEMATIC (SINGLE PURGE)

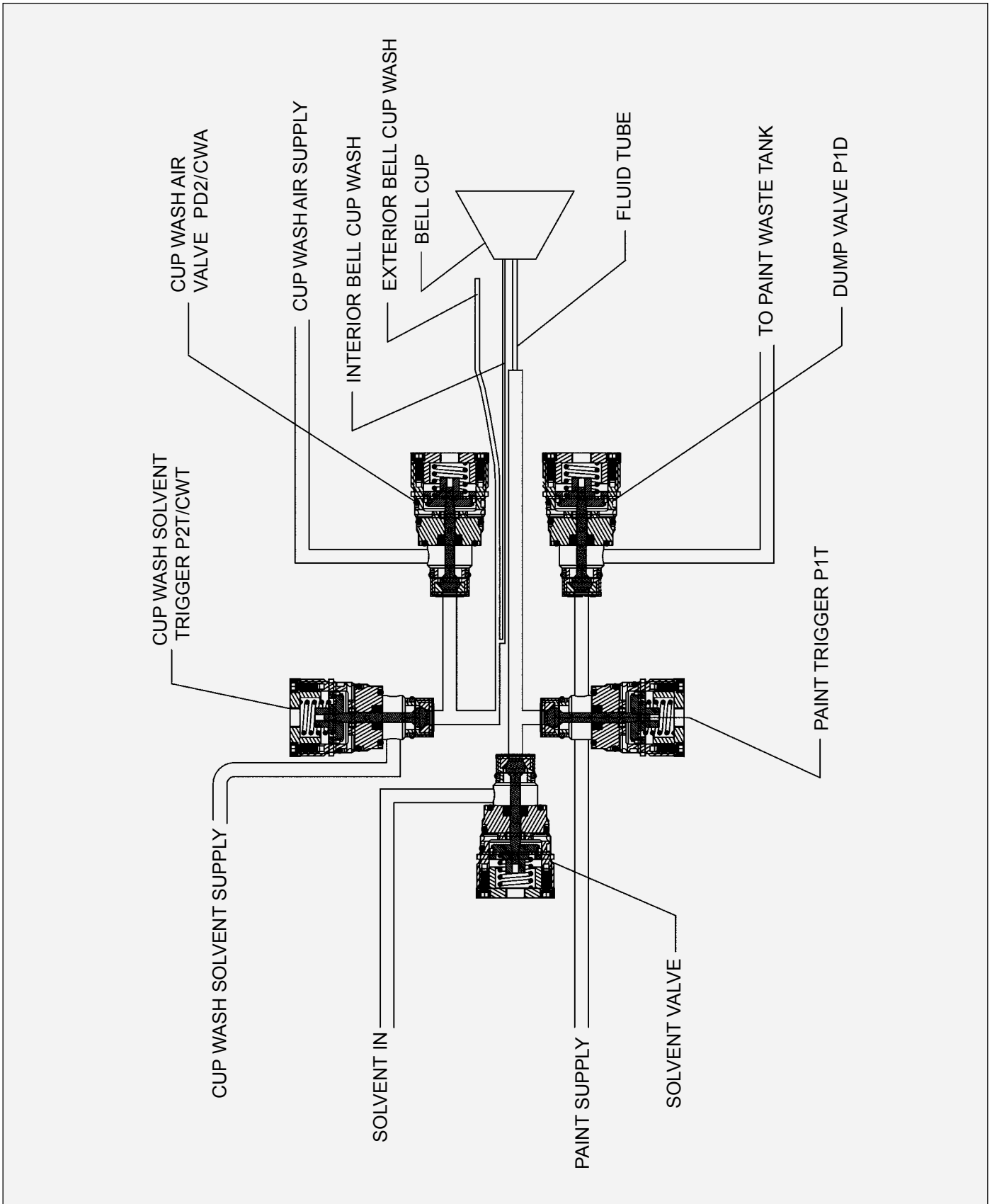

Single Purge Manifold with Integrated Internal/External Cup Wash Valve Schematic

INSTALLATION

AIR FILTER INSTALLATION (GENERAL GUIDELINES)

The following air filter installation guidelines are essential for optimum performance:

1. Use 25mm OD (1-Inch OD) minimum inbound main air line.
2. Use only recommended pre-filters and bearing air filters as shown in "Air filtration Requirements" chart in the "Installation" section. Additional system air filtration (i.e., refrigerated air dryer) may also be used if desired.
3. Mount all the air filters as close as possible to the RMA-550 applicator. (DO NOT mount further than 30-Feet (9.1 meters) away.)
4. DO NOT use tape, pipe dope, or other thread sealant downstream of the bearing air filter. Loose flakes of tape or other sealant can break loose and plug the very fine air holes in the turbine air bearings.
5. Air heaters are highly recommended for use in the system to minimize the effect of excessively humid conditions and maintain turbine load capabilities. If the heated air will exceed 120°F (48.9°C), the heater must be located after all filters to prevent damage to the filter media.

With the exception of fluid, dump, and bearing air, all other pilot and air supply lines should be bulk-headed and their diameters increased one size. For example: Turbine air should be increased to 12mm OD from bulkhead plate to the volume booster or heater outlet.

NOTE

- Each applicator must have its own filter for bearing air. Recommended: RPM-418 or equivalent.

Volume Booster Recommendation (Turbine Air): (For use with A11065-05 Air Heater or Non-Air Heater System)

Ransburg Part # A11111-00

- Pilot Operated Regulator Non-Bleed Pilot
- SCFM: 200
- Supply: 300 psi
- Temperature Range: 40° - 120° F

Volume booster type must be a non-bleed version. Tubing from the MicroPak 2e to be 4mm (5/32") x 4.5 meters (15 ft.) long, minimum. Longer lengths may result in some speed respond delays.

No kinks or pinched tubing allowed. These may result in lack of speed response.

WARNING

- Arching/fire hazard exists if ungrounded metal connections (air or fluid) are used in the spray area. Use plastic non-conductive connections, or ensure metal connections are at ground potential.

PFA* Tubing must never be replaced with nylon tubing. Only Polyamide Nylon tubing can be used for air connections and dump line outlets. Polyurethane tubing is prohibited.

* PFA = PERFLUOROALKOXY

TUBE SIZE AIR PRESSURE REQUIREMENTS

	Tube Size	Air Pressure Requirements
Bearing Air Supply (BA/PT)	8 X 6 mm (Natural)	90 psi +/- 10 (621 kPa +/- 69)
Bearing Air Return (BA RTN)	4mm (5/32") (Yellow)	90 psi +/- 10 at atomizer card (621 kPa +/- 69)
Turbine Air (T.A.)	10 X 8mm (Green)	Variable
Outer Air (SAO/FA)	8 X 6mm (Gray)	Variable
Pattern Control Air #1 (SAI/AA)	8 X 6mm (Blue)	Variable
Brake Air (BRK) (if used)	8 X 6 mm (Natural)	60-100 psi (414-689 kPa)
Paint Valve #1 (P1T)	4mm (5/32") (Green)	80 psi +/- 10 (552 kPa +/- 69)
Dump Valve #1 Control (P1D)	4mm (5/32") (Gray)	80 psi +/- 10 (552 kPa +/- 69)
Solvent Valve Control (ST/RP)	4mm (5/32") (Blue)	80 psi +/- 10 (552 kPa +/- 69)
Paint Valve #2 / Cupwash Control (P2T/CWT)	4mm (5/32") (Natural)	80 psi +/- 10 (552 kPa +/- 69)
Dump Valve #2 / Air Control (P2D/CWA)	4mm (5/32") (Black)	80 psi +/- 10 (552 kPa +/- 69)

EQUIPMENT GROUNDING / SAFETY RECOMMENDATIONS

In electrostatic coating systems, the flow of high voltage power from the power supply to the atomizer is insulated from ground and isolated from all other function's equipment. When the voltage reaches the atomizer, it is transferred to the coating material where, by introducing a negative charge, it causes the atomized fluid to seek the nearest positive ground. In a properly constructed and operated system, that ground will be the target object.

The directed conduction of the electric charge, through its array of wires, cables, and equipment, is accompanied by a variety of stray electrical charges passing through the air by various means such as: air ionization, charged particles in the air and radiated energy. Such charges may be attracted to any conductive material in the spray area. If the conductive material does not provide a safe drain to electrical ground, which will allow the charge to dissipate as fast as it accumulates, it may store the charge. When its electrical storage limit is reached, or when it is breached by external circumstances (such as the approach of a grounded object or person, or one at lower potential), it may discharge its stored charge to the nearest ground. If there is no safe path to ground (such as a ground wire or braided cable) it may discharge through the air as a spark. A spark may ignite the flammable atmosphere of a spray area. The hazard area extends from the point of origin up to as much as a twenty foot radius. (See the NFPA-33 for definition and limitations of a hazard area.)

It is a simple, but vital matter to be sure that all conductive objects within the spray area are grounded. All cabinets, housing, bases, supports, and stands, which are not by design, insulated from ground, be connected directly and INDIVIDUALLY to earth ground. ***Resting on a concrete floor or being attached to a building column may not always be sufficient ground.***

In order to provide the best ground connection possible, always attach a ground wire or insulated braided cable to the terminal indicated by the ground symbol and then to a proven ground. Always check ground connections for integrity. Some items, such as rotators and paint stands, may be supported on an insulator, but all components of the system up to the insulator **MUST** be grounded.



WARNING

- It is the end user's responsibility that the robot adapter and robot plate are at ground potential through the robot wrist with the supplied A11680-XX ground cable assembly. (1 megohm or less)

NOTE

► Ransburg recommends that ground connections to earth ground be 3/4" insulated copper braided wire. Grounds between assemblies within a machine should be run to a central point within the machine using #18 insulated stranded copper wire minimum. All connections should be mechanically sound and have less than 5 ohms of resistance between assemblies and the common point. The resistance between the central point and earth ground should be less than 5 ohms as well.

Where items are mounted directly on structural components such as building columns, the ground connection MUST still be made. In many cases the structural component may be painted or coated with an insulated material and in all cases, the equipment will provide the necessary connection at one end, but the user must be sure that the other end is secured to an earth ground. This may be achieved by the use of a standard ground clamp (properly secured), by brazing or by piercing the structural component enough to assure connection. All ground connections should be made to the most conductive metallic structural ground available.

To be sure that everything is properly grounded, the following steps should be undertaken at least daily:

1. Inspect all ground wires. Look for good, firm joints at all points of connection. Look for breaks in the ground wire. Repair all defects IMMEDIATELY!
2. Inspect the floor or grates for excessive accumulation of dried coating material or other residue. If there is any, remove it!

SAFE GROUNDING IS A MATTER OF PROPER EQUIPMENT MAINTENANCE AND INSTALLATION, CORRECT OPERATION AND GOOD HOUSEKEEPING.

Daily inspection of grounding apparatus and conditions, however, will help prevent hazards that are caused by normal operations.

BE SURE THAT:

1. All objects in the spray area are grounded.
2. Personnel in the spray area are properly grounded. (Conductive safety shoes and coveralls.)
3. That the target object is properly grounded (less than 1 megohm resistance).
4. That the high voltage is off except during normal application.
5. That the high voltage is off and applicators are grounded during maintenance operations.
6. The spray area is kept free of accumulated coating deposits.
7. All combustible liquids in the spray area (outside of automatic delivery systems) are kept to minimum and are kept in fire safe, grounded containers. (See NFPA-30 and chapter 6 of NFPA-33.)
8. Proper ventilation is provided.
9. Personnel must thoroughly understand the equipment, its operation and maintenance, and all safety precautions.
10. Fluid supplies are grounded. (Less than 1 megohm resistance)
11. Ensure ground cable (A11680-XX) supplied at robot plate and tubing bundle assembly is connected to known earth ground.

AIR HEATER REQUIREMENTS

Turbine drive air expands as it moves through the turbine wheel cavity and as it exits the turbine from the exhaust port. This expansion will cause cooling of the exhaust air and the surfaces it contacts. This same expansion cooling can occur across the shaping air exit ports. This cooling affect can cause surface temperatures to fall below the dew point of the booth, which will result in condensation on the interior and exterior of the atomizer, machine, and its components. It is even possible that the temperature of the supply air may be below the booth dew point, even without additional expansion cooling.

Condensation is especially probable in waterborne applications when booth temperature and relative humidity levels are typically maintained very high. This condensation will allow sufficient conductivity of the surfaces such that they act as an erratic ground source potential. This can cause damage to the equipment.

It is therefore, a requirement that turbine exhaust air temperature be maintained above the booth dew point to prevent condensation from forming on atomizer surfaces. Doing so will eliminate moisture as a potential defect in painted surfaces as well as extending equipment life. Thus, it is recommended that air heaters be installed into the atomizer air supply lines, i.e. turbine drive air, shaping air, and seal air. The air heaters must be of sufficient capacity, capable of raising the incoming air temperature at least 40°F (4.4°C) at a flow rate of 60 SCFM per applicator.

The actual air heater process setting depends on applicator fluid flow rate load, booth conditions, turbine airflow settings, and incoming air temperature. The heater should be set as low as possible, sufficient to maintain the applicator surface temperatures above the dew point in the booth.

Example: With the incoming air temperature at 72°F (22.2°C), and RMA-550 with 65mm bell cup rotating unloaded at 60 krpm has a turbine outlet temperature drop of approximately 28°F (15.6°C) @ 40 krpm unloaded, Δ ~14°F (~7.8°C). Referring to the ASHRAE Psychrometric chart, the saturation temperature range (dew point) of a spray booth maintained at 70-75°F/65-70% RH is 62-68°F (21.1-23.9°C/65-70% RH is 16.7-20°C). Thus it is almost certain that the surface temperatures of the applicator will fall below the dew point of the booth, and an air heater will be needed in this case.

To prevent condensation, a Ransburg air heater assembly (A13230-XX) should be assembled after the air filters and volume booster. (See heater and filtration options later in this manual).

AIR HEATER AND FILTRATION OPTIONS

NOTE

- Failure to use an air heater may cause damage to equipment or ruin the finished component being processed.

NOTE

- Connect air heater to turbine air tubing.

NOTE

- If using the A11065-05 Air Heater, air filters equivalent to HAF-503, HAF-508 and RPM-418 must be used. (See descriptions in this manual).

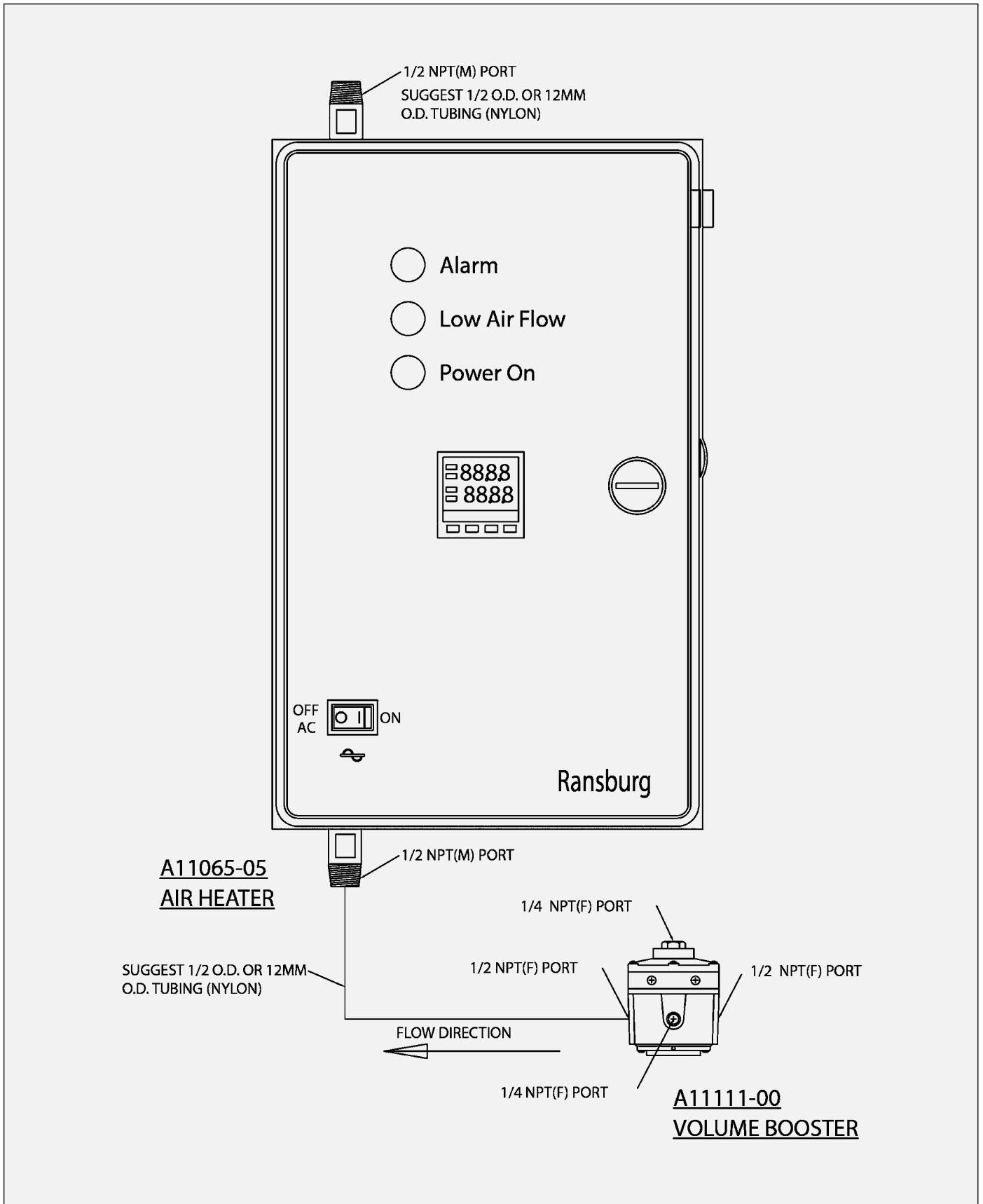

A11065-05 Air Heater

A13230-XX AIR HEATER AND FILTER COMBINATION

This combination includes filtration for turbine as well as bearing air.

NOTE

- Volume booster type must be a non-bleed version. Tubing from the MicroPak 2e to be 4mm (5/32") x 4.5 meters (15 ft.) long, minimum. Longer lengths may result in some speed respond delays.
- No kinks or pinched tubing allowed. These may result in lack of speed response.

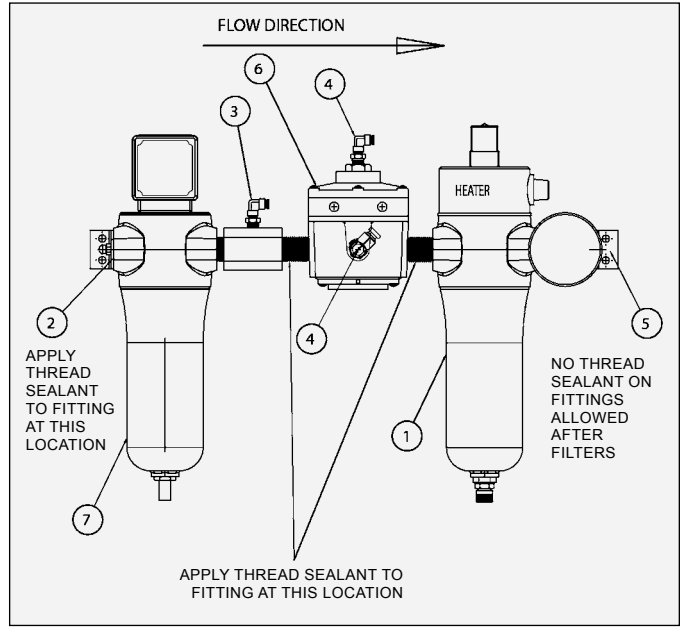

FILTER & HEATER ASSEMBLY A13230-XX

Dash No.	Description	"A"	"B"	"C"	"D"	"E"
A13230-01	115 V.@ 13A METRIC FITTINGS	A13434-01	A13426-00	A13429-00	A13433-00	A13726-00
A13230-02	230 V.@ 6.5A METRIC FITTINGS	A13434-02	A13426-00	A13429-00	A13433-00	A13726-00
A13230-03	115 V.@ 13A FRACTIONAL FITTINGS	A13434-01	SSP-6439	A13428-00	A13433-00	A13727-00
A13230-04	230 V.@ 6.5A FRACTIONAL FITTINGS	A13434-02	SSP-6439	A13428-00	A13433-00	A13727-00

A13230-XX AIR HEATER AND FILTER COMBINATION

Item	Part #	Description	Qty.
1	"A"	AIR BLOCK, NIPPLES & AIR HEATER	1
2	A13427-00	INLET FITTING, 3/8 NPS(M) X 1/2 NPT(M)	1
3	"B"	BEARING AIR FEED, SWIVEL ELBOW 1/4 O.D.TUBE X 1/4 NPT(M)	1
		BEARING AIR FEED, 6mm O.D. TUBE X 1/4 NPT(M) STRAIGHT ADAPTER	
4	79253-02	AIR FITTING, SWIVEL ELBOW 5/32 O.D. TUBE X 1/4 NPT(M)	2
5	"C"	OUTLET FITTING, 1/2 O.D. TUBE X 1/2 NPT(M) STAINLESS STEEL	1
		OUTLET FITTING, 12mm O.D. TUBE X 1/2 NPT(M) STAINLESS STEEL	
6	A11111-00	VOLUME BOOSTER	1
7	"D"	AIR FILTER & NIPPLE INCLUDED	1
8	SI-13-07	A13230-XX SERVICE LITERATURE (PROVIDED BY OTHER)	REF.

ALL UNITS: REPLACEMENT PARTS: (SERVICE NOTE)
 HEATING ELEMENT USE: A13432-01 FORA13230-01ANDA13230-03 (115V UNITS)
 A13432-02 FORA13230-02ANDA13230-04 (230V UNITS)
 AIR FILTER ELEMENT USE A13232-00
 THERMOMETER USE A13431-00

AIR FILTRATION REQUIREMENTS WHEN USED WITH A11065-05 AIR HEATER OR NO AIR HEATER

Ransburg Filter Model No.	Description / Specifications	Replacement Element Part No.
HAF-503	Pre-filter, removes coarse amounts of oil, moisture and dirt. Used upstream of HAF-508 pre-filter (used in systems with poor air quality).	HAF-15 Element One
HAF-508	Pre-filter, coalescing type, 136 SCFM, 98.5% efficiency particulate removal .3 to .6 micron, max. aerosol passed 1.0 micron, max. solid passed .4 micron (dependent upon SCFM requirement per applicator, one HAF-508 can be used with up to three RMA-550 assemblies).	HAF-38 Elements, Carton of 4
RPM-418	Bearing air filter, coalescing type, 19 SCFM, 99.995% efficiency particulate removal .3 to .6 micron, max. RMA-550 passed .6 micron max. solid passed .2 micron (one per RMA-550)	RPM-33 Elements, Carton of 8

⚠ CAUTION

- Air must be properly filtered to ensure extended turbine life and to prevent contamination of the paint finish. Air which is not adequately filtered will foul the turbine air bearings and cause turbine failure. The correct type filters must be used in an RMA-550 system. The filter elements must be replaced on a regular schedule to assure clean air.
- It is the user’s responsibility to ensure clean air at all times. Turbine failure resulting from contaminated air will not be covered under warranty. If other filters are incorporated in the system, the filters to be used must have filtering capacities equal or better than those shown in “Air Filtration Requirements Charts.”
- The user must ensure the bearing air supply is not inadvertently turned off while the RMA-550 air motor is turning. This will cause air bearing failure.

NOTE

- Each applicator must have its own filter for bearing air. Recommended: RPM-418 or equivalent.

⚠ CAUTION

- Any user supplied air hoses must be rated at a minimum working pressure of 150 psig (10 bar).

MOUNTING

The RMA-550 is equipped with a quick disconnect assembly. The quick disconnect feature consists of a robot plate which is permanently attached to the robot through a wrist adapter plate, and a mating bell plate which is a part of the RMA-550 Rotary atomizer assembly. The atomizer is secured to the robot plate with a threaded retaining ring. A plastic or metal ring is available.

ELECTRICAL AND FIBER OPTIC CONNECTIONS

The fiber optic connection is made on the back of the atomizer's robot plate. The fiber optic cable comes pre-assembled with connectors that are secured in place by set screws tightened from the side of the robot plate. An adequate ground must be provided to the mounting plate to ensure that fluid fittings, etc. are at ground potential.

A robot fiber optic cable with a metal ferrule is available in 3 ft. and 6 ft. lengths and is the preferred cable. The ferrule end is to be inserted into the aluminum robot plate. Set screw tightened to 15-20 lbs./in. (1.68-2.23Nm).

Maximum amount of splices for any length of cable is 3, including the robot plate and transceiver card. The speed detection signal may be affected if splices are exceeded. Length in any combination for the fiber optic is 100-feet.

A fiber optic splice connector is available to connect 2 fiber optic cables together. A bulkhead bracket A13393-00 is available for mounting in the robot arm along with the low voltage connector.

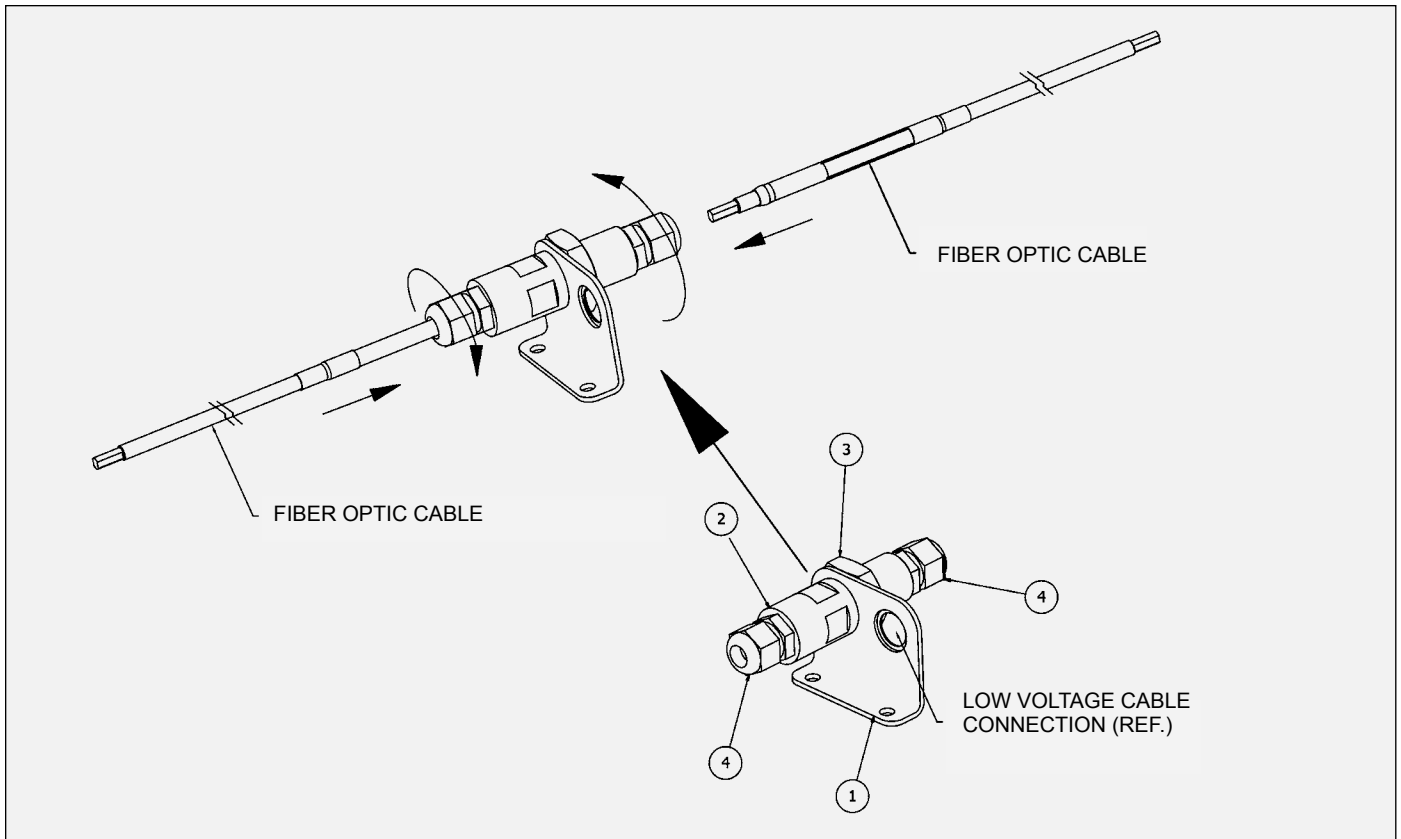

A13392-00 Fiber Optic/Low Voltage Connection Kit

A13392-00 FIBER OPTIC/LOW VOLTAGE CONNECTOR KIT - PARTS LIST

Item	Qty.	Part #	Description
1	1	A13393-00	BRACKET, FIBER OPTIC/LOW VOLTAGE
2	1	A13391-00	FIBER OPTIC BULKHEAD CONNECTOR
3	1	A13537-00	HEX NUT, M22 X 1.5
4	2	80073-00	STRAIN RELIEF, CABLE GLAND

FLUID TUBING CONNECTION REQUIREMENTS

	Fixed Atomizer	Maximum Pressure
Paint Line #1 (P1.IN)	8mm OD X 5mm ID (PFA)	150 psi max. (1034 kPa)
Cup Wash Solvent Line (SOL)	8mm OD X 5mm ID (PFA)	150 psi max. (1034 kPa)
Dump Line #1 (DL1)	10mm OD X 7mm ID (Nylon)	100 psi max. (689 kPa)
Paint Line #2 / Cup Wash Solvent (P2/CW SOLV)	8mm OD X 5mm ID (PFA)	150 psi max. (1034 kPa)
Dump Line #2 / Cupwash Air (DL2 /AIR)	10mm OD X 7mm ID (Nylon)	100 psi max. (689 kPa)

FLUID CONNECTIONS

The paint, solvent, and dump fluid tubing are connected on the back of the robot plate with stainless steel fittings and PFA tubing. Fluid tubing requirements are shown in “Fluid Tubing Connection Requirements” above.

DUAL PURGE MANIFOLD

When the dual purge valve manifold option is selected, connect 8mm x 5mm PFA tubing to the fitting on the robot plate labeled “CW”. With this version, a remote valve stack with solvent and air is required to perform the internal and external cup wash function.

SINGLE PURGE MANIFOLD

When the single purge manifold option is selected, connect an 8mm x 5mm PFA tube to the fitting on the robot plate labeled “P2/CW SOLV” and a 10mm x 7mm Nylon tube to the fitting on the robot plate labeled “DL2/AIR”. With this version, the valves are integrated into the valve manifold and a remote air and solvent stack is not required.

TYPICAL INSTALLATION

The “Typical Installation of RMA-550” figure in the “Installation” section shows a typical installation of the RMA-550 and the wiring installation of the applicator with the MicroPak 2e.

TYPICAL INSTALLATION OF RMA-550

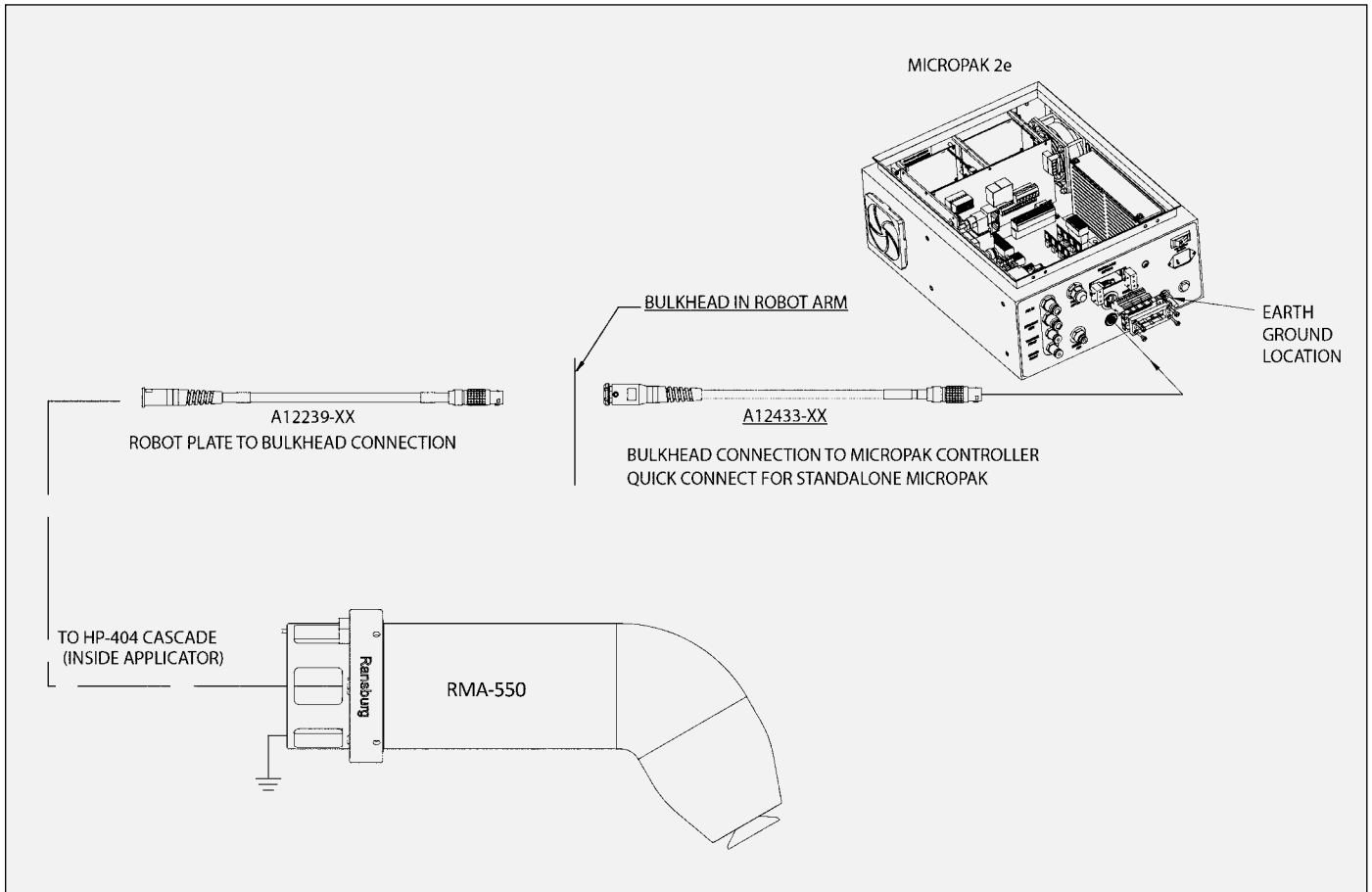

TUBING BUNDLE INSTALLATION BUNDLE LUBRICANT

Typically, the tubing bundle is pulled through the robot arm from the robot wrist side. Keep the bundle taped except for the bundle that will be inside the arm. Pull the tubing through the wrist and arm, leaving about 250mm (10-inch) of tubing sticking out the front of the wrist plate. (See “Tubing Bundle Installation” figure in the “Installation” section.)

Fasten the cable bundle at the exit of the arm. Push the robot spacer plate and applicator mounting plate to the robot wrist plate aligning the top dead center marks of the spacer plate and robot wrist plate. Fasten using appropriate screws. Installing the tubing bundle in this fashion will increase tubing bundle life significantly.

When the tubing bundle is installed, it should be lubricated with a generous amount of lubricant to increase the service life of the tubes. A recommended lubricant is Shell Alvania EP #02. There are other lubricants that are available for use. Prior to using a lubricant, ensure it is silicone free, resists heat breakdown, and is compatible with the materials it will contact. It is recommended that tubing bundles be re-greased every six months.

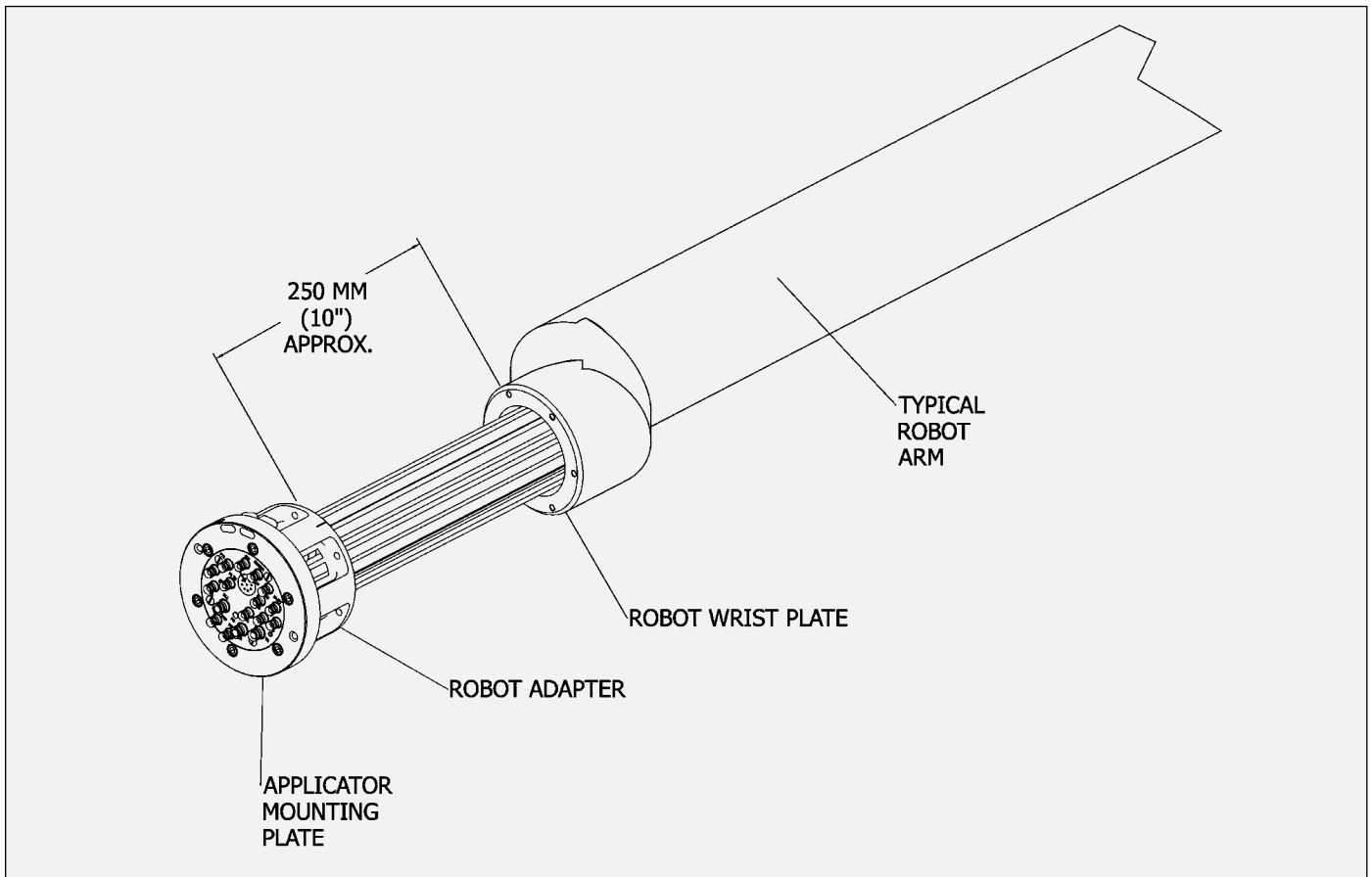

INTERLOCKS

The following system interlocks are required to prevent equipment damage.

- Bearing air should remain on at all times and should be shut-off by turning off the main air to the pneumatic control cabinet.
- It should not be possible for the coating material to be sprayed unless the turbine is spinning.
- Two interconnected bearing air ports are provided, one for supply air and the other to be used as a return signal for measuring bearing air pressure at the atomizer. If bearing air falls below 80 psi (551.6 kPa) at the atomizer, the turbine air should be automatically interlocked to shut off.
- High voltage must be interlocked with the solvent valve pilot signal to prevent solvent flow while high voltage is energized.
- Turbine air and brake air must be interlocked to prevent both from being used simultaneously.
- Any other interlocks required by local national code or international code.
- High voltage must be interlocked with the booth entry door.
- High voltage must be interlocked through the power unit with conveyor and booth fan air.

AUTOMATED CAP CLEANERS

- Voltage **OFF**
- Bell cup rotating (20-30 KRPM)
- Shape air **ON** (70 SLPM min.)
- Applicator centered in device

CAUTION

- When the turbine air is turned off, the turbine will continue to operate or “coast down” for about two minutes. Provisions should be made to assure that the operator waits at least three minutes, after shutting off the turbine air and before shutting off the main air supply.
- The bell cup must be removed when making flow checks. If the paint is turned on when the bell is mounted and the turbine shaft is not rotating, paint will enter the shaft and possibly damage the air bearing. Material flow checks (flow rate verification) must be made with the bell cup off and the turbine not rotating. Normally pneumatic interlocks will not allow the paint to trigger on when the turbine air is off.

WARNING

- The high voltage and/or coating material must never be turned on unless the bell cup is mounted on the motor shaft and the turbine is rotating.
- Pneumatic input to the turbine air inlet must be controlled to prevent the turbine from exceeding the maximum rated speed of 55,000 rpm. (See “Specifications” in the “Introduction” section.)
- High voltage must never be turned on while cleaning solvent is being sprayed either through the applicator supply or the cup wash line. High voltage and both solvent triggers must be interlocked (direct charge only).
- **Never spray solvent with high voltage on.**

OPERATION

WARNING

- Operators must be fully trained in safe operation of electrostatic equipment. Operators must read all instructions and safety precautions prior to using this equipment (see NFPA-33, EN 50 176).

As with any spray finishing system, operation of the RMA-550 involves properly setting the operating parameters to obtain the best finish quality for the coating material being sprayed, while maintaining correct operation and reliability of the equipment used. Adjustments to operating parameters, which cover spraying, cleaning, and on/off control, include:

- Coating materials
- Fluid flow rate control
- Fluid valve control
- Turbine speed
- Bearing air adjustment
- Shaping air
- Brake air
- Electrostatic voltage
- Target distance

WARNING

- Electrical discharge of a high electrical capacitance fluid/paint system can cause fire or explosion with some materials. If arcing occurs when a specific coating material is used, turn the system off and verify that the fluid is non-flammable. In these conditions the system is capable of releasing sufficient electrical and thermal energy to cause ignition of specific hazardous materials in the air.

FLUID FLOW RATE CONTROL

Externally mounted fluid regulators or gear pumps are typically used to control fluid flow. Paint is supplied to the RMA-550 by way of the tubing bundle through the robot arm.

The atomizer assembly is equipped with micro valves which are pneumatically operated to direct the flow of paint to either the feed tube or dump line and to supply an intermittent solvent to clean the interior and exterior of the bell cup.

The feed tube has several sized removable tips available from .7mm - 1.6mm (.027–inch to .062-inch). The viscosity and volume of the coating material being sprayed determine the correct size of feed tube tip for each installation. (Reference “Fluid Tip Flow Rate” chart in the “Introduction” section.)

Fluid Flow Rate Check

In the test mode, the flow rate can be measured by removing the bell cup from the atomizer, turning the fluid flow on, and capturing the material in a graduated beaker or measuring cup for a fixed period of time (shaping air, high voltage, and turbine air must be off).

WARNING

- **Danger of shock and/or personal injury can occur. Proper grounding procedures must be followed. Personnel must never work around the turbine when the turbine is spinning or when high voltage is turned on.**

(See “Circuit Diagram” in the “Introduction” section.) The fluid valves in the RMA-550 are actuated by an air signal. The air pressure must be greater than 70 psi (482.6 kPa) to assure proper actuation of the valve. Applying air to the valve actuator turns on the fluid or air for that valve.

The paint trigger valve controls the paint flow to the bell. When actuated, paint flows through the valve to the fluid tube, and into the rear of the bell cup. The bell cup must be spinning at least 30,000 rpm when fluid is turned on to enable the fluid to flow through the bell paint passage and be atomized.

The dump valve controls the paint flow through the dump line. When actuated, paint flow is directed to the dump return line. This provides a method of rapidly removing paint from the incoming line for cleaning and/or color change. Normally, the dump valve is not actuated at the same time as the paint trigger valve since the trigger valve is intended to cause the fluid to flow to the bell at the prescribed input pressure.

The solvent valve controls the flow of cup wash solvent. When actuated, solvent flows through a separate fluid tube passage and into the bell cup. This provides cleaning of the inside of the bell cup. The outside of the cup is simultaneously cleaned by a nozzle mounted on the shaping air ring and shroud. The solvent valve should never be triggered at the same time as the paint trigger valve to prevent solvent from flowing backward into the paint line.

To color change the applicator, a solvent air chop must be provided through the main paint line (see “Typical Installation RMA-550” in the “Installation” section).



WARNING

- **Never perform the interior/exterior cup clean process with high voltage on.**

CAUTION

- The normal fluid flow range is 25-500 cc/min. During a color change or when flushing the system, high flow rates may be required. However, the maximum flow rate through the bell cup must not exceed 500 cc/min., to avoid solvent or paint from flooding into the internal portion of the air bearing motor assembly or front shroud.
- **High voltage must be interlocked with the solvent valve to prevent solvent spraying while high voltage is on.**

DUAL PURGE SPRAYING

The RMA-550 has dual purge capability. This means the applicator can continue to spray paint, at voltage, while side “B” or “Paint 2” is being flushed or cleaned. To operate in the dual purge mode, **two (2) separate color valve systems must be installed.**

TURBINE SPEED

Turbine speed is determined by the input air pressure/flow at the rear of the atomizer.

Turbine speed is intended to be closed loop controlled using the fiber optic speed transmitter, located on the turbine manifold. A speed input to a remote speed controller, such as the MicroPak 2e, is required. (See “Speed and Pressure” charts in the “Introduction” section.)

NOTE

- The bell rotational speed determines the quality of atomization and can be varied for various paint flow rates and paint formulations. For optimum transfer efficiency and spray pattern control, the bell rotational speed should be set at the minimum required to achieve proper atomization. **Excessive speed reduces transfer efficiency!**

⚠ WARNING

- **DO NOT** exceed the maximum rated operating speed and turbine inlet pressure. Excessive speed may cause air turbine damage or damage to the bell.

BEARING AIR ADJUSTMENT

The nominal bearing air pressure is 90 psi (620.5 kPa), measured at the rear of the atomizer. Minimum pressure is 80 psi (551.6 kPa) and maximum pressure is 100 psi (689.5 kPa). The turbine should never be operated with less than 80 psi (551.6 kPa) bearing air pressure.

Bearing air must be present when turning the turbine on. Bearing air must remain on when the turbine air is turned off until the turbine stops spinning. Never turn off bearing air to cause the turbine to stop spinning. If connected, brake air can be used to slow the turbine.

The RMA-550 is equipped with a bearing air return line to monitor bearing air pressure at the turbine manifold. When connected to the remote speed controller, operation of the turbine will automatically be shut down whenever the bearing air pressure falls below the setting of 80 psi (551.6 kPa).

⚠ WARNING

- Bearing air **MUST BE ON** and supplied at a minimum of 80 psig (551.6 kPa) whenever the turbine is operated. If not, severe bearing damage will occur. It is recommended that bearing air be left turned on at all times, except during maintenance or disassembly.
- Bearing damage (and subsequent turbine failure) caused by running the turbine without bearing air **WILL NOT** be covered under the Ransburg warranty.

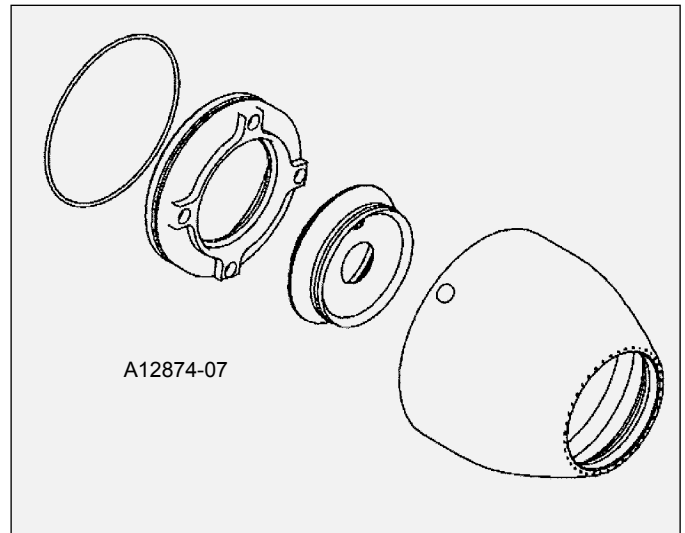
SHAPING AIR KIT #1**A12874-07 Single Shaping Air Kits**

As the name implies, shaping air outlet supply air that is counter to the rotation of the bell cup. Connection is made using the “blue” 8mm tube labeled “SAI” on the tubing bundle. The other 8mm tube labeled “SAO” is “gray” in color and must be plugged. However, if additional air is required, this tube can be connected to a secondary controlled air source. Precautions must be taken that one does not have a significantly higher pressure than the other to avoid any back flow. (See “Pressure and Flow Data Charts” in the “Introduction” section.)

NOTE

- A minimum of 70 slpm (2.6SCFM) should always be kept flowing in the inner shaping air passage to keep the face of the applicator clean during manual cleaning breaks.

SHAPING AIR KIT #2

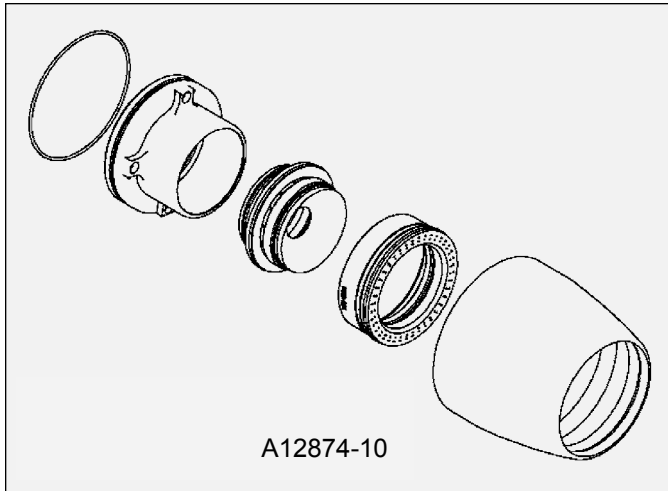

A12874-10 Dual Shaping Air Kit

As the name implies, both shaping air outlets supply air that is counter to the rotation of the bell cup. Both sets of shaping air holes are independently controlled. The inner set of holes are supplied by connecting the “blue” tube labeled “SAI” on the tubing bundle to a regulated air source. The outer set of shaping air holes are supplied by connecting the “gray” tube labeled “SAO” on the tubing bundle to a regulated source. The air supplies work in combination with each other to provide desired results.

NOTE

- A minimum of 70 slpm (2.6 SCFM) should always be kept flowing in the inner shaping air passage to keep the face of the applicator clean during manual cleaning breaks or in automated cap cleaning equipment.

BRAKE AIR

Brake air is used to slow the turbine speed in a minimum length of time. It is advantageous for short cycle times during color change, or may be used to reduce speed or stop the turbine. Never operate brake air with the turbine air on.

ELECTROSTATIC VOLTAGE

The RMA-550 Rotary Atomizer receives a low voltage control input from the MicroPak 2e to control the operating electrostatic voltage. (Refer to the current “MicroPak 2e” manual for detailed for operating instructions.)

NOTE

- If paint defects occur, such as fatty edges or picture framing, reducing the voltage should be a last resort. To correct the problem, lead and lag trigger adjustments should be optimized first.
- The electrostatic voltage applied to the RMA-550 will affect pattern size, transfer efficiency, wrap and penetration into cavity areas. A setting of 30-90 kV is appropriate for most applications.

TARGET DISTANCE

The distance from the RMA-550 rotary atomizer to target affects the spray application. For instance, closer distances give a smaller spray pattern and greater efficiency. Increasing the distance will give a larger pattern and possibly reduce efficiency. If the distance is too great, material may “wrap back” on the RMA-550.

GENERAL OPERATING SEQUENCE



WARNING

- It is recommended to leave bearing air on, unless the applicator is being serviced or removed for service.

Normally, for painting application, the process sequence should always be:

- Bearing air on (Always On)
- Turbine air on
- Turbine speed to application speed
- Shaping air on
- Start fluid flow off part
- Voltage on

After spraying the object, the sequence should be:

- Voltage lowered to 30-50 kV
- Fluid off
- Shaping air to setback volume
- Turbine speed to set back speed (30,000 rpm recommended)

Recommended sample cup flush sequence is as follows (voltage must be off) (internal and external cup wash):

1. Turbine speed set to 25,000-30,000 rpm.
2. Set shaping to 350-450 SLPM (12.4-15.9 SCFM).
3. Point atomizer at a grounded object such as a booth grate.
4. Maintain solvent pressure of 100-150 psi (689-1,034 kPa). Maintain air push pressure at 80-100 psi (552-689 kPa).
5. Use an alternating trigger sequence of solvent/air to create a chopping effect. Always ensure that the last step in the sequence is an air push.

A typical sequence is .2 seconds solvent, 1.0 second air push, 1.7 seconds solvent and 2.0 seconds final air push. This sequence may be modified for other paints and applications

6. It is recommended that an in-line fluid filter be installed to ensure that no foreign debris enters the fluid tip or the external wash nozzle.

The RMA-550 is versatile in processing the finish of a component. It can be setup as shown in "Typical Paint Sequence" figure.

Recommended sample cup purge sequence is as follows (voltage must be off) (internal cup cleaning):

1. Turbine speed set to 25,000-30,000 rpm.
2. Increase shaping air to 350-450 SLPM (12.4-15.9 SCFM).
3. Paint atomizer at booth grate or insert into bell cleaning station.
4. Maintain solvent pressure of 100-150 (689-1,034 kPa). Maintain air push pressure at 80-100 psi (552-689 kPa).
5. Use an alternating trigger sequence of solvent/air to create a chopping effect. Always ensure that the last step in the sequence is an air push.
6. A typical sequence is .3 seconds solvent, 1.7 seconds air push, repeat 3 times. This sequence may be modified for other paint and applications.

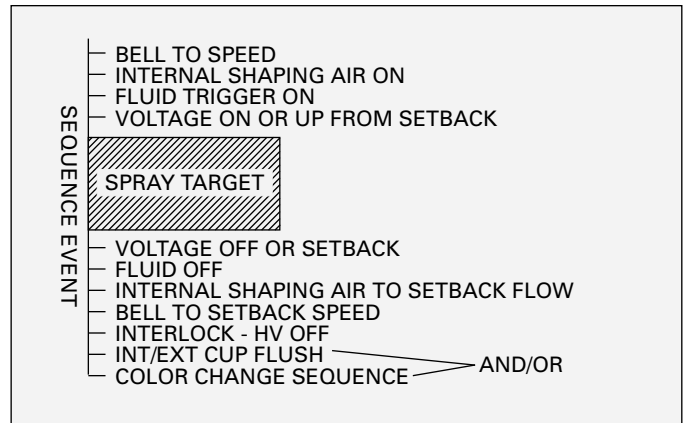

Typical Paint Sequence

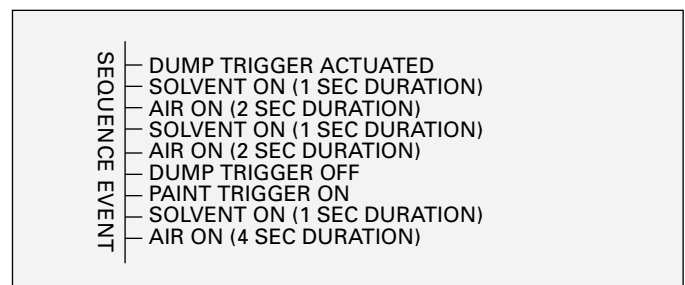

Typical Color Change Sequence

Sequence Event Explanation:

1. **Bell to Speed** - This is accomplished by a set point command from either the PLC, robot, or other input device, through the I/O module.
2. **Shaping Air** - Set to 350-450 SLPM (12.4-15.9 SCFM) while performing a cup flush.
3. **Voltage On** - The voltage is turned on from a signal to the MicroPak 2e. The lag time to full voltage may be reduced if a setback voltage is used. Recommended setback voltage is between 30 kV and 50 kV.
4. **Trigger Fluid** - An air signal is sent through the PT line of the tubing bundle. This should occur when the target is 6-12-inches (152.4-304.8mm) from the applicator centerline. (Not to be confused with target distance.)
5. **Voltage Off/Setback Voltage** - Immediately precedes the trigger off. Using a setback voltage shortens the cascade voltage ramp up time.
6. **Fluid Trigger Off** - This should occur when the target is typically 0-6-inches (0-152.4mm) past the applicator centerline.
7. **Shaping Air to Setback** - The setback flow of air should never be below 70 slpm (2.6 SCFM) for the shape air.

8. Color Change Sequence - Used when color is changed one to the other. Typical sequence is shown in “Typical Color Change Sequence” figure in the “Operation” section. The sequence shown is a starting point for processing, but the final sequence will depend on the material being sprayed and the solvent used to purge the applicator with.

screw holding the flanged plastic 9 pin connector. Loosen with a 3/32” hex key wrench. Pull the cable out from the robot plate end. Install new cable in reverse direction, align the 9 pin connector with the alignment mark on the robot plate face and tighten set screw. Torque 5-10 lbs·in (0.56-1.13 Nm).

NOTE

► During this sequence, the applicator should be moved to a position to collect the waste material.

⚠ WARNING

► Cable connector shell must be electrically grounded. Electrical noise or other interference may result.

LOW VOLTAGE CABLE INSTALLATION AND REMOVAL

(See “Quick Disconnect Cables” and “Low Voltage Cable On Robot” figures)

A low voltage cable is provided to send power to the high voltage cascade in the atomizer as well as sending important information during operation back to the MicroPak 2e controls. Typically an A12239-06 or A12239-10 is installed from the robot plate to the robot bulkhead, then an extension (A12433-XX) can be ordered in various lengths depending on the distance required to reach from the robot arm to the MicroPak 2e. The ends of the cables have a male and female quick disconnect end. This provides for a quick and easy removal of the cable at the robot plate if servicing or replacement is required.

It is important the quick disconnect fitting be secured to a good ground source. The A12433-XX cable is supplied with a ground cable which can be secured to the bulkhead connector and the other end to a known ground source. The cable can also be grounded by attaching the bulkhead connector to a grounded bulkhead plate. The bulkhead plate can be no more than 1/8-inch (3.18mm) in thickness. The bracket should be made as in “Low Voltage Cable On Robot” figure to hold the connector from turning. To mate the connectors, align the raised key section of the cable on the applicator end with the key groove of the cable that goes to the MicroPak 2e. Push the male end into the mating connector until an audible click is heard. Tug on cable to ensure that it is locked in place. To remove this section from the robot plate, remove the applicator. Locate the set

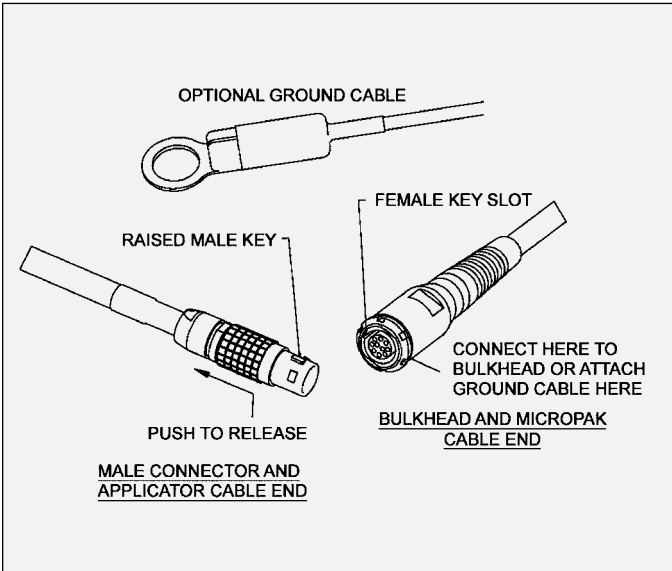

Quick-Disconnect Cables

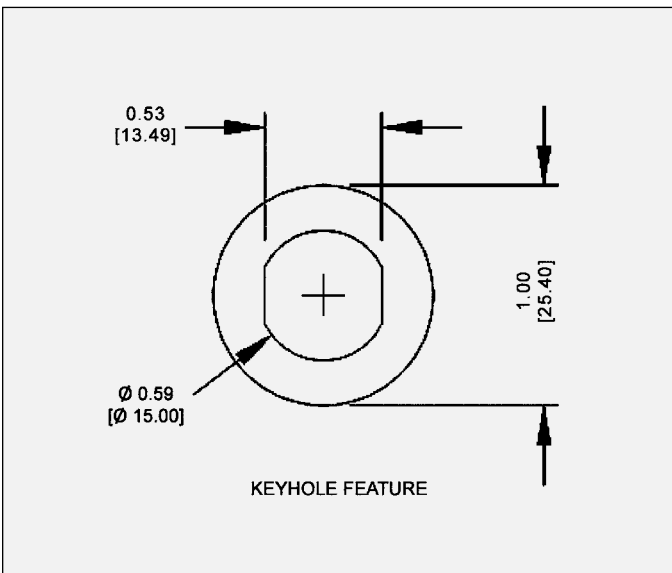

Bulkhead Cut-Out Diagram

LOW VOLTAGE CABLE INSTALLATION AND REMOVAL

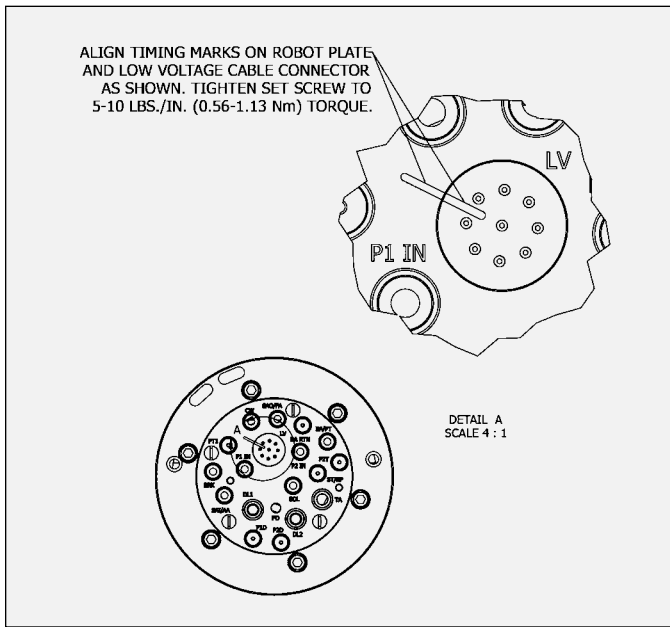
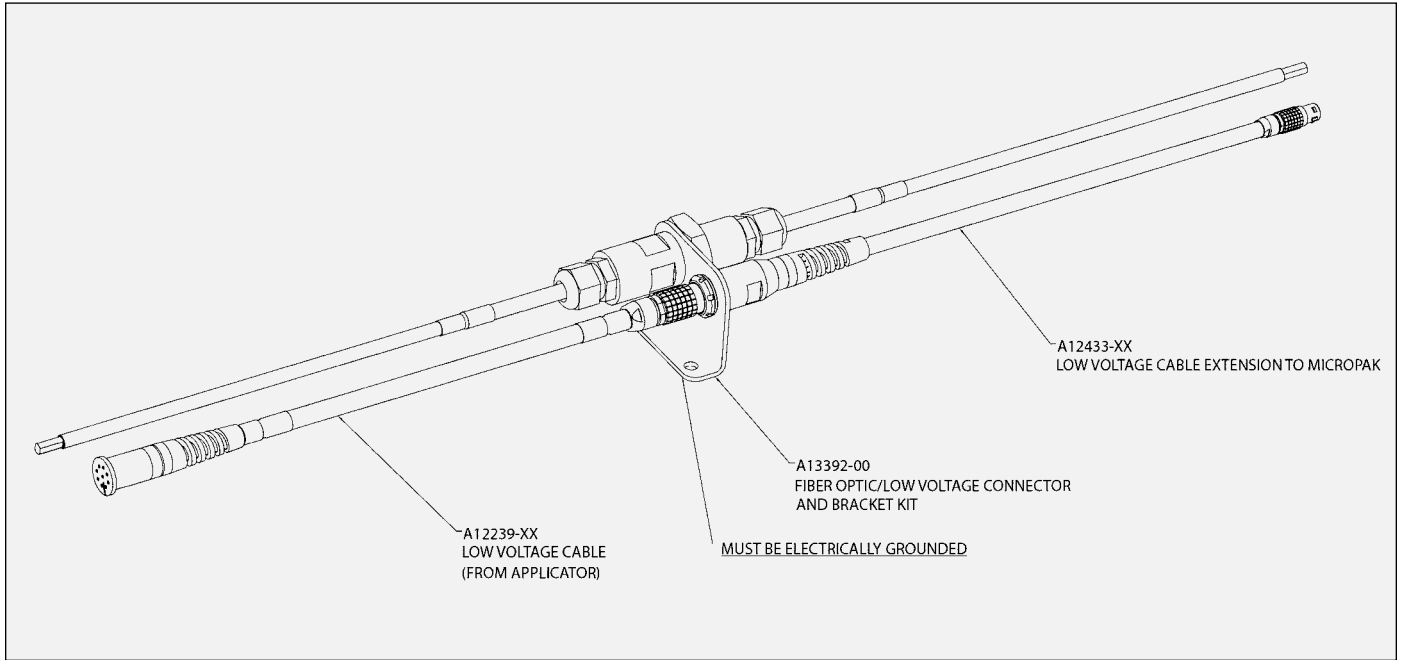

Robot Plate

LOW VOLTAGE CABLE ON ROBOT

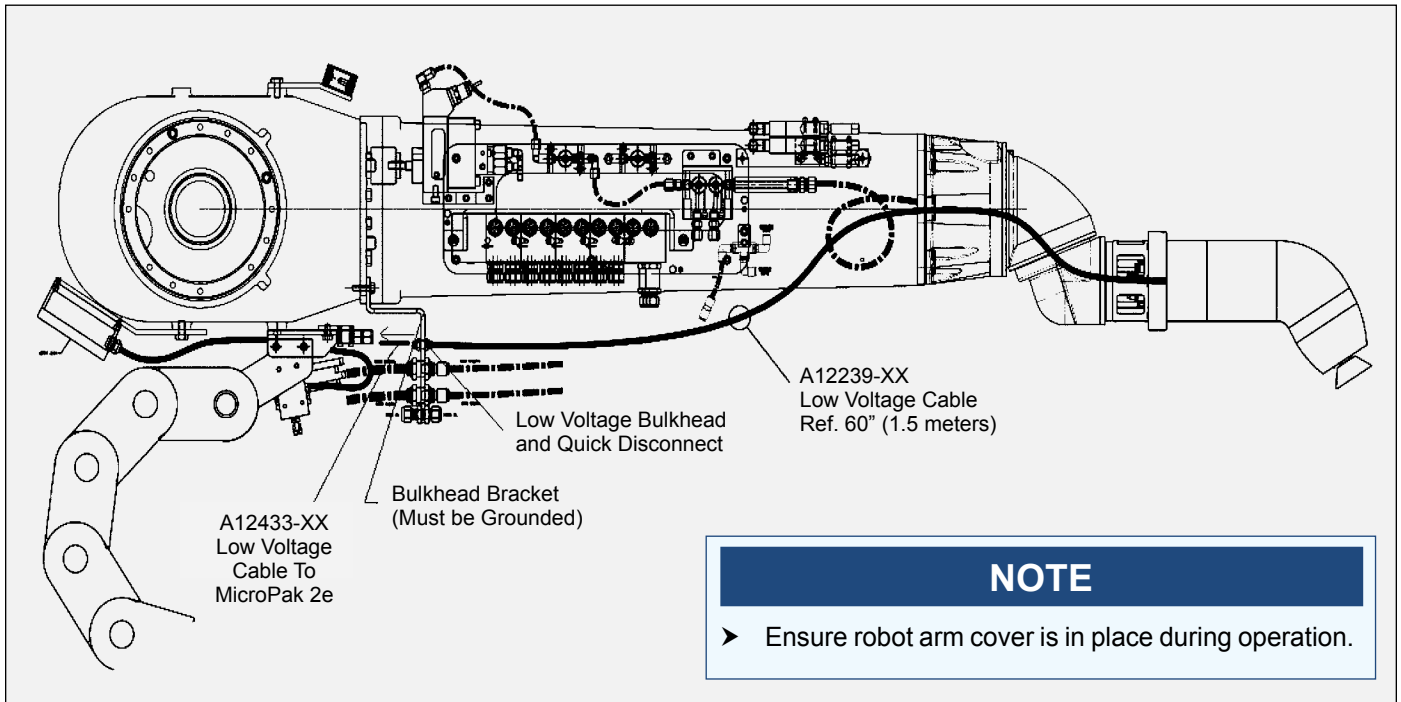

TURBINE AIR

NOTE

- If the turbine air is heated, check the maximum rated temperature for the air supply tubing to be used. Polyethylene tubing is rated for a maximum of 80° F (27° C). Nylon tubing is rated for 200°F (95°C) maximum.

WARNING

- Nonignitable cleaning fluids are preferred.
- Ignitable cleaning liquids shall only be used if, after disconnection of the high voltage supply, all parts under high voltage are discharged to an energy of less than 0.24mJ before these parts may be serviced.
- Appropriate measures shall ensure that the resistance to earth of the suspending point of the work piece shall not exceed 1 MΩ measured at 500v or 1000v.
- Use only electrically conductive container for cleaning liquids; the containers must be earthed to ground.

MAINTENANCE

Good maintenance is essential to safe and productive operation. Schedules should be established by the user, based on the following general information and observations of the initial production requirements.

The Ransburg maintenance and safety information should be made available to each operator.

Normal fire protection measures are necessary, including proper storage of paints and solvents and the proper disposal of waste. Ready access to appropriate fire extinguishing equipment is required. For details, consult the appropriate NFPA safety information, your local fire codes, local painting equipment standards, OSHA requirements, as well as your insurance carrier's information.

WARNING

- Unexpected robot movement can be hazardous. Do not adjust or repair the RMA-550 when the robot is operating or waiting to start. The robot must be locked out and secured against restart.
- Do not adjust or repair the RMA-550 when the power supply is ON. Secure the supply against a restart.
- Those solvents used for cleaning must have a flash point at minimum of 15°C (27°F) greater than ambient temperature. It is the end users responsibility to ensure this condition is met.
- Never remove RMA-550 while it is under pressure.
- If ignitable fluids are used for cleaning purposes, all parts must be completely discharged of high voltage.

O-RINGS

All O-rings in this atomizer are solvent proof except those on the air bearing spindle. These O-rings must not be soaked in solvent; if these are exposed or soaked in solvent, they must be replaced. These O-rings are engineered to provide a fit between the air bearing spindle and it's mating parts to reduce or eliminate harmonic resonance (vibration).

Some O-rings are encapsulated. These O-rings have a limited amount of stretch and will not return to their original diameters if over stretched. These O-rings are subject to being distorted more easily than rubber O-rings, so it is important that they be sufficiently lubricated when mating parts are installed onto them. They also will take a square set over time and should be replaced periodically if mating parts are removed repeatedly or if a new mating part is installed onto them.

Any O-ring that is cracked, nicked, or distorted must be replaced.

A suitable lubricant is food grade petroleum jelly or A11545-00 Petrolatum Jell.

WARNING

- Never touch the atomizer bell while it is spinning. The front edge of the bell can easily cut into human skin or cut through gloves and other materials. Be sure the atomizer bell has stopped spinning before attempting to touch it. Approximate time for the bell to stop spinning after turning off turbine drive air is three minutes.

WARNING

- Electrical shock and fire hazards can exist during maintenance. MicroPak 2e single bell controller must be turned off before entering the spray area and performing any maintenance procedures on the atomizer. Spray booth fans should remain on while cleaning with solvents.
- Ensure high voltage is off during any manual cleaning procedure.
- Ensure that all energy sources are dissipated, (electrical, air, paint, solvent, etc.) before removing the applicator or performing any maintenance.

In addition to the previous Warning, which relates to potential safety hazards, the following information must be observed to prevent damage to the equipment.

⚠ CAUTION

- **DO NOT** immerse the RMA-550 turbine in solvent or other liquids. Turbine components will be damaged and warranty will be voided.
- Bearing air must be on during all cleaning procedures to protect the air bearing components.

⚠ CAUTION

- The maximum flow rate of 500 cc/min. must not be exceeded during a flush routine. Use of an inline fluid restrictor is recommended.

CLEANING PROCEDURES

Internal Fluid Path Purge Cleaning

Cleaning the incoming paint line (from paint supply source such as color manifold through the fluid manifold and bell assembly): Turn off the high voltage and turn on the color stack trigger valve for solvent supply. With the bell spinning, open the dump valve and flush the incoming paint line with solvent or an air/solvent chop. Make sure the last step of the sequence is air to purge the dump line of remaining solvent. To speed the loading of the new paint, leave the dump line open to allow the air in front of the paint push to escape. The length of time the dump valve is open depends on several factors such as viscosity, paint pressure, etc. Timing should be such that the dump is closed as the paint reaches the trigger valve in the atomizer. Paint in the dump line may cause high voltage issues.

The fluid coil and fluid tube can be cleaned independently by actuating the solvent valve in the atomizer. **High voltage must be turned OFF during this operation and the bell cup must be spinning (typically 30,000 rpm for cup flushing sequences).**

Bell Cup Cleaning (Cup Wash) Without Cleaning the Incoming Paint Line

Turn off the high voltage and trigger valve. With the bell spinning at 30,000 rpm, turn on the external solvent valve to allow cleaning solvent to flow through the manifold passages, through the fluid tube, and onto the bell. The spinning bell will atomize the solvent, clean out the bell passages both internally and externally. It is always required to blow the solvent line dry after the cleaning operation. Typical bell speed during the cup flush sequence is 30,000 rpm. Follow sequence as outlined for cup wash in “General Operating Sequence” in the “Operation” section.

External Atomizer Surface Cleaning

- Verify that the high voltage is turned off.
- All external surfaces may be cleaned by using a mild solvent and lint free rags to hand wipe the RMA-550. Turbine drive air must be off, but leave bearing air on. The inner and outer shaping air (if applicable) should have approximately 70 SLPM air flow through each to prevent the solvent from entering these passages.
- Do not spray the RMA-550 with a solvent applicator used for cleaning. The cleaning fluid under pressure may aid conductive materials to work into hard to clean areas or may allow fluids to be forced into the turbine assembly.
- Do not reuse an atomizer bell cup that shows any sign of damage such as nicks, heavy scratches, dents, or excessive wear.
- For best operating conditions, the atomizer surfaces must be dry
- Always final wipe all parts with a non-polar solvent and wipe dry (high flash Naphtha, etc.).

⚠ WARNING

- **NEVER** wrap the applicator in plastic to keep it clean. A surface charge may build up on the plastic surface and discharge to the nearest grounded object. Efficiency of the applicator will also be reduced and damage or failure of the applicator components may occur. **WRAPPING THE APPLICATOR IN PLASTIC WILL VOID WARRANTY.**

⚠ WARNING

- To reduce the risk of fire or explosion. Solvents used for cleaning must have a flash point at minimum of 15° C (27°F) greater than the ambient temperature. It is the end users responsibility to ensure this condition is met. Since electrostatic equipment is involved, these solvents should also be non-polar. Example of non-flammable, non-polar solvents for cleaning are: amyl acetate, methyl amyl acetate, high flash naphtha, and mineral spirits.
- Use a solvent compatible with the coating being applied to clean the exterior of the applicator . Use VM & P Naphtha as a final wipe to remove surface conductivity.
- When using a rag to hand wipe the Applicator, the turbine air should be off, but leave both the shaping air and bearing air turned on. Ensure that rotation has come to a complete stop.

VIBRATION NOISE

If the RMA-550 is vibrating or making an unusually loud noise, it usually means there is an imbalance situation. The atomizer bell cup may have dried paint on it or the bell may be physically damaged, or there may be paint trapped between the bell cup and shaft preventing the bell cup from properly seating. If any of these conditions exist, they **MUST** be corrected. Excessive imbalance caused by one of these conditions may result in bearing damage and turbine failure. Warranty **DOES NOT** cover failure caused by imbalanced loading conditions.

To determine if the bell is dirty or damaged, remove the bell cup and turn the turbine ON. If the noise is eliminated, the bell cup is the problem. If the noise continues, the turbine may be damaged and should be inspected. Excessive air required to achieve same speed may indicate a faulty or contaminated turbine. **DO NOT** continue to operate a noisy turbine.

⚠ WARNING

- If a bell cup comes off a rotating shaft because of motor seizing or any other reason, the Atomizer and bell cup must be returned to Ransburg for inspection and evaluation to determine if the bell can be used in operation.

TURBINE MAINTENANCE

DO NOT attempt to rebuild the turbine. Any endeavor to disassemble a turbine during the warranty period will void the warranty. Contact your authorized distributor or Ransburg for instructions.

GENERAL/PREVENTIVE MAINTENANCE

Verify daily that the operating parameters have not varied significantly from the normal. A drastic change in high voltage, operating current, turbine air, or shaping air, can be an early indicator of potential component failure.

A laminated poster entitled “Rotary Atomizer Checklist” (AER0075-05) is included with the assembly in the Literature Kit to be posted near the station as a handy reference.

Due to the close proximity of high voltage to ground potential, a schedule must be developed for equipment maintenance (cleanliness).

PREVENTIVE MAINTENANCE**Daily Maintenance (During Each Preventive Maintenance Break)**

1. Verify that high voltage is OFF and that shaping air, bearing air, and turbine drive air are ON.
2. Open the dump valve, flushing all paint from the supply lines and valve module.
3. Open the solvent valve, flushing all paint from the fluid tube and through the atomizer bell assembly.
4. Re-verify that high voltage is OFF, turbine drive air is OFF, and that the bell cup has stopped spinning. The bearing air and shaping air should remain ON.
5. Clean all external surfaces of the applicator using a lint-free rag dampened with solvent.
6. After cleaning, all conductive residue must be removed using a non-conductive solvent. Since electrostatic equipment is involved, these solvents should also be non-polar (Naphtha).

7. Inspect bell cup for nicks, dents, heavy scratches, or excessive wear. Replace if necessary.
8. Check bell cup tightness. Tighten to 10-15 lbs•in (1.13-1.69 Nm) torque.
9. Check the amount of paint build-up on the outer protective cloth covers, if used. If excessive, replace covers as required. If cloths are wet, find source and replace with dry cloth covers.



WARNING

- The high voltage must be turned OFF before entering the spray area and performing any maintenance procedures. Spray booth exhaust fan(s) should remain ON while cleaning the equipment with solvents.
- Make sure high voltage is OFF before approaching applicator with solvent cloth.
- DO NOT use reclaim solvent containing d-Limonene. This can cause damage to certain plastic components.
- DO NOT stop bell rotation by using a rag, gloved hand, or anything abrasive against the bell cup edge.



CAUTION

- Maximum flow rate should not exceed 500 cc/min.
- Daily removal and soaking of the bell cup may not be required if the bell cup is properly flushed. However, the frequency of the feed tube and internal motor shaft inspection indicated below under weekly maintenance can be done daily and later adjusted to weekly or as required depending on the results of the inspection.



WARNING

- In the event the bell cup comes in contact with a part, that cup should be replaced before continuing to spray.
- Do not place high voltage test probe on bell edge unless rotation is fully stopped.
- Make sure that no solvent or other contamination is allowed to enter the motor assembly (air bearing and outer shaft).

NOTE

- Refer to the “Troubleshooting Guide” in the “Maintenance” section for details on determining the causes of low or no high voltage at the bell cup.

Weekly Maintenance (Prior to Start or End of Production Week)

- Monitor rotational speed of all bells at the speed control. Investigate cause if abnormal.
- Monitor high voltage and current output indicated on the MicroPak 2e display. Investigate cause if abnormal.
- Check paint flow on all bells at minimum and maximum specified settings by taking beakered readings.
- Check solvent flow by opening solvent valve and taking a beakered reading (should be within approx. 10% of target flow rate).
- Paint residue found in the shaping air holes is not acceptable and must be removed prior to applicator use (see “Cleaning Shaping Air Holes” in the “Maintenance” section).
- Clean any paint on outer surface of front and rear housing with a soft cloth dampened with solvent. (See “Warning” on avoiding the use of cleaning solvent containing d-Limonene.)
- Remove the front shroud and check for any signs of solvent or paint leakage. Clean as required as required.
- Remove bell cup. Clean with a soft brush as required. Remove from cleaning solution and blow dry before replacing. **Do not use an ultrasonic cleaner.**
- With bearing air off, carefully inspect the feed tube tip and clean any paint build-up that has occurred on the feed tube tip. Using a pen light, determine if there is build-up of paint in the motor shaft and/or around the paint feed tube. If so, remove the motor assembly following the disassembly procedures and clean out the inside diameter of the motor shaft using a tube brush and solvent. Clean the outer surfaces of the feed tube.

NOTE

➤ It may be necessary to remove the bell cups for cleaning more frequently than weekly. (See Note under “Daily Maintenance” in the “Maintenance” section.)

- Visually inspect for signs of fluid leaks around fluid connections and manifold. Correct problem and clean paint from all components, including internal portion of shroud.
- Reinstall bell cup and front shroud, replace cover on the outer housing. (Refer to “Disassembly Procedures” in the “Maintenance” section for definite instructions.)
- Recheck bell cup tightness. Torque to 10-15 lbs•in (1.13-1.69 Nm).

BELL CUP PREVENTIVE MAINTENANCE

It is the user’s responsibility to ensure proper maintenance of the atomizer bell at all times. Bell cup failure due to inadequate cleaning or handling will not be covered under the Warranty. The “**DO NOT**” bullets (see “Operator/Maintenance Warnings” in the “Maintenance” section) listed are some examples of improper handling which could adversely affect performance or personnel safety and should not be attempted for any reason.

! WARNING

➤ If rated speed of applicator is exceeded, bell cup must be inspected for any damage.

Bell Cup Handling

Always verify that high voltage is turned off and the atomizer bell has stopped spinning before performing any type of handling maintenance.

Bell Cup Replacement

Bell cup wear is dependent on many factors such as bell speed, flow rate, and type of coating being applied.

NOTE

➤ It may be advantageous to develop a maintenance schedule for hand cleaning and inspection of the atomizer bell cup. (See Service Literature “IL-337”).

! WARNING

➤ Do not attempt to clean the bell edge while the bell is rotating. When attempting to stop or slow down the bell cup, do not hold a rag or gloved hand against the bell edge. This could damage the bell edge, which would adversely affect transfer efficiency and coating quality.

BELL CUP CLEANING

Always verify that high voltage is OFF and that the atomizer bell is spinning before performing any type of color change or bell flush cleaning cycle.

To reduce the risk of fire or explosion, the solvents used for exterior cleaning must have flash points at minimum of 15° C (27°F) greater than ambient temperature. It is the end users responsibility to insure this condition is met. Since electrostatic equipment is involved, these solvents should also be non-polar.

Solvents used for equipment flushing should have flash points equal to or higher than those of the coating material being sprayed.

1. The atomizer bell will normally be fully cleaned during a bell flush cycle. Flushing should be done before any down time or break in production. A bell flush cycle may also be required while spraying batch parts of the same color. Verify that high voltage is off and that the atomizer bell is spinning before flushing through the bell.
2. If there is any remaining paint build-up on any areas of the bell after flushing, the bell cup should be removed for hand cleaning. The bell’s leading edge, splash plate, serration cuts, and rear of cup are some examples of areas for special attention.

Bell Cup Soaking

3. Soaking the bell cup in solvent will not aid in loosening or removing paint build-up! The bell should be dipped in an appropriate solvent or the solution may be allowed to flow over and into the bell while cleaning. Use a soft cloth to remove the paint and a soft tool like a toothpick to clean the paint holes. Be sure that all signs of paint are removed. Rinse and dry the bell. **Do not use an ultrasonic cleaner.**

Manual Inspection

4. Inspection of the bell's semiconductive coating is required to determine if wear or flaking has occurred. Excessive loss of bell coating can cause poor transfer efficiency and paint wrap back onto the atomizer.
5. Check the center holes of the splash plate for wear. Hold splash plate up to a light source and look straight into the holes. If light is clearly seen, the angled holes are worn and the bell cup must be replaced.
6. Use a soft bristle brush dipped in solvent to remove paint build-up from the serration cuts, paint feed holes or slots, and external and internal surfaces of the bell.
7. A soft, lint free rag dampened with solvent may be used to remove any paint residue from the external and internal surfaces of the bell.
8. After removing all paint build-up or residue, rinse the bell in clean solvent and blow dry.
9. Before reinstalling the bell on the shaft, check the mating surfaces of the thread and taper for any paint build-up or residue. Also, check the fluid tip, fluid tube outside diameter, and the shaft for any further paint build-up. These surfaces should be cleaned before installing the bell.
10. It is recommended that extra bell cups be purchased. The cups can then be cleaned off line in an automated cup cleaner.
11. Reinstall cups to proper torque 10-15 lbs•in (1.13-1.69 Nm).

CAUTION

- Care must be taken when mounting the bell assembly onto the motor shaft. The bell should turn on freely for several turns or until it fully bottoms on the motor shaft. If resistance is felt when the bell is first being turned onto the shaft, do not proceed further, the bell may be cross-threaded on the shaft. Remove the cup and carefully reinstall. If it is still difficult to turn, replace the bell.

WARNING

- A bell assembly that is cross-threaded on the shaft can damage the bell, motor or shaping air housing and may come off the shaft while rotating.

CAUTION

- Do not use abrasive materials which will scratch or damage the plastic bell, or which will scratch the semiconductive coating on the surface of the bell.
- Before reinstalling the bell onto the shaft, check and clean the tapered mating surfaces of the turbine shaft and bell for any paint residue.

Using an atomizer bell with paint buildup may cause a bell imbalance. An imbalanced bell may cause bearing damage and turbine failure, or may create mechanical stress on the plastic bell when operating at high speeds. Excessive paint residue caught between the internal tapered surface which seats in the motor shaft can prevent the bell from seating properly and results in an unbalanced turbine condition.

CLEANING SHAPING AIR HOLES

In order to maintain uniform pattern control, the shaping air holes of the inner ring and the shaping air cap must be clean and free of any blockage.

It is best to leave the shaping air supply ON during normal production break cleaning periods. Shaping air can be reduced to 70 slpm during this time. This will help stop material from entering the passage ways.

Periodically (weekly) the outer shaping air cap and the inner shaping air ring should be removed and thoroughly cleaned. Use of an ultrasonic cleaner would make cleaning of hole diameters easier. Inspect all holes for blockage. Blow holes clear with compressed air after some time of soaking in solvent. **DO NOT use any type of pick to clear the holes.** Damage may result to parts and could affect performance of the equipment. If holes are damaged (oversized holes, blockage, and gages) it must be replaced.

BELL CUP TESTING (NON-ROTATING)

Check bell cup voltage using Ransburg test meter kit, part number 76652-01 or 76652-04. Verify that the output voltages have not varied much from the set up standard. A drastic change in voltage can be an early indicator of a component or system problem.

Bell Cup Handling

Always verify that high voltage is turned OFF and the atomizer bell has stopped spinning before performing any type of handling maintenance.

OPERATOR / MAINTENANCE

WARNINGS



Do not attempt to hold a rag or a gloved hand against the bell edge to stop or slow down a rotating bell.



Do not attempt to clean the bell edge while the bell is rotating.



Do not attempt to use sharp or abrasive materials to clean the bell, which will scratch or damage the plastic bell.



Do not use sharp or abrasive materials to clean the bell, which will scratch the semi-conductive coating on the surface of the bell.



Do not attempt to place a high voltage probe on the bell edge unless rotation is full stopped.



Do not soak bell cup in solvents.



Do not use ultrasonic devices to clean the atomizer bell cup.



Do not use ammonia solutions or reclaim solvent containing d-Limonene to clean the bell cups.



Do not use the bell cup to spray coatings containing N-methyl pyrrolidone.



Do not use N-methyl pyrrolidone to clean the bell cup.



Do not reuse an atomizer bell that shows signs of damage such as nicks, heavy scratches, dents, or excessive wear (defined under "Bell Cup Cleaning").



DO NOT reuse bell cup that shows signs of any damage if atomizer has exceeded rated speed.

RMA-550 PREVENTIVE MAINTENANCE SCHEDULE

Procedure	Frequency (Maximum)							
	Mid-Shift	End of Shift	Weekly	2 Weeks	Monthly	3 Months	6 Months	Yearly
Mid Shift Cleaning • Wipe shroud • Visually inspect cup	●	●	●					
End of Shift Cleaning • Wipe shroud • Wipe bell cup down • Change cloth cover		●						
Shaping Air Shroud • Clean inner shape air ring • Clean outer shape air ring • Remove and clean	●	●	●					
Bell cup removal/inspection/ cleaning/Tightening	●	●	●					
Fluid tip inspection/cleaning		●	●					
Inspect Valve and Seat Assembly in valve module for leaking				●				
Replace Valves and Seats in valve module							●	●
Low Voltage Cable Inspections				●	●			
High Voltage Testing						●		
Inspection of Tubing Bundle					●			
Regrease Tubing Bundle						●	●	
Replace Tubing Bundle							●	●
Inspect Turbine Spindle taper and threads		●	●					
Replace Bell Cups					●	●	●	●
Inspect all screws • Replace if broken • Inspect for wear • Tighten per specifications					●			
Inspect and Clean Spindle Bore and Fluid Tube OD		●	●					
Inspect for Fluid Leaks	Daily							
Check External Cup Flush Carbide Tip for blockage	●	●						
Inspect O-rings on tubing bundle fittings				●	●			
Inspect tubing bundle fitting seals and receivers					●			

DISASSEMBLY PROCEDURES

⚠ CAUTION

- Before servicing bell, ensure that all voltage is de-energized and the bell cup is not rotating. Minimum 3 minute wait after turbine air has been shut off.

NOTE

- For reassembly instructions, use the reverse of the following disassembly procedures.
- To facilitate atomizer removal from hose manifold, a robot program should be made that purges all paints and solvents from the RMA-550. Ideally it would then position the bell assembly in a bell removal position where the bell cup is pointed downward at a 30° angle. Any residual solvents would be contained in the “J bend” of the robot wrist.
- All O-rings described in the “Maintenance” section of this manual should be lubricated with a food grade petroleum jelly or with A11545 lubricant.

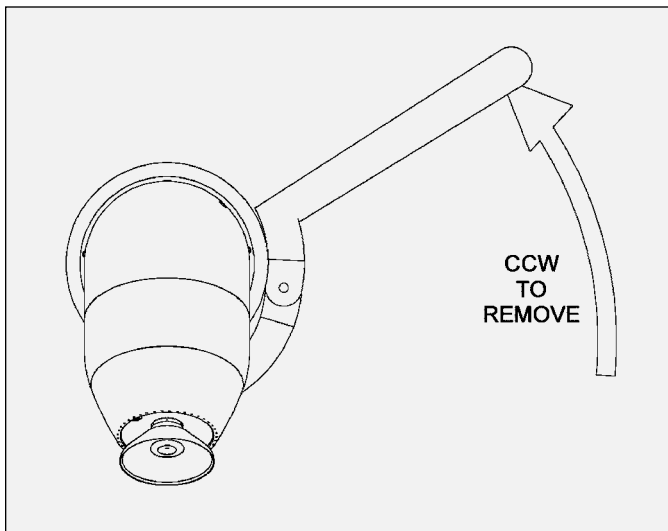

Applicator Removal from Robot

⚠ WARNING

- Prior to removing applicator from the robot, the following tasks must be completed.
 - Robot put into E-stop mode, locked and tagged out.
 - All fluid passages are cleaned, purged out, and depressurized.
 - Air turned off.

⚠ WARNING

- Carefully remove the quick disconnect ring to ensure any residual line pressure has been relieved to atmosphere.

Bell Cup Removal / Replacement

NOTE

- The bell cup should always be the first component removed if any maintenance is performed. Following the procedure will minimize the risk of damage to the cup.

Lay the applicator on its side in a clean and secure area, preferably an area where regular maintenance is performed. Using the large open end of the bell cup / combo wrench (A12061-00) on the flats of the turbine shaft, carefully hold the outside of the bell cup with one hand while applying a clockwise force to the wrench. The bell cup is a right hand thread and must be turned counter-clockwise to remove.

Place the bell cup in a safe and secure place. Carefully inspect the cup for any damage. If there is any damage to the cup, it must be replaced.

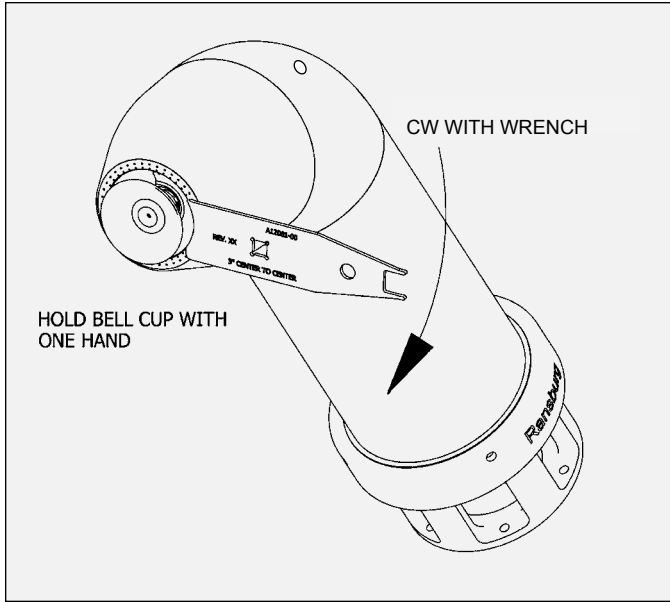

Bell Cup Removal

CAUTION

➤ Failure to replace a damaged bell cup will cause premature turbine failure. Warranty will not be honored if the bell cup is damaged.

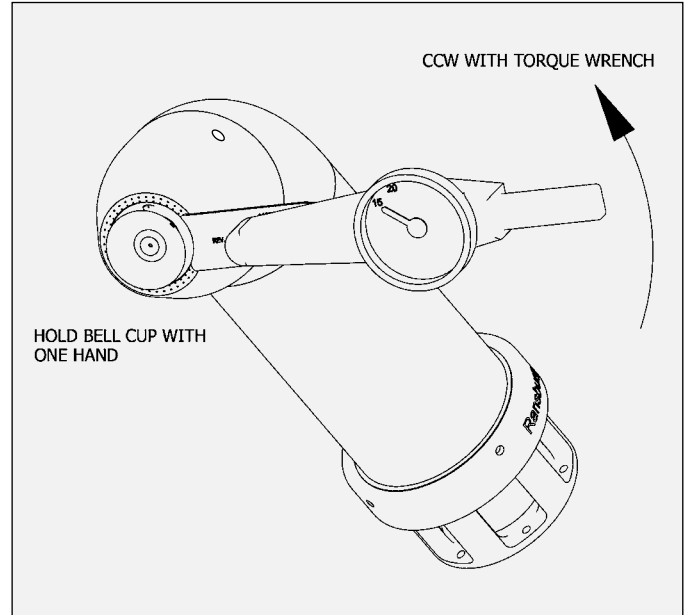

Bell Cup Installation

NOTE

➤ There is a 3-inch center-to-center distance between the bell cup and the 3/8-inch socket square on the wrench. This distance must be factored in when reading the proper torque on the wrench.

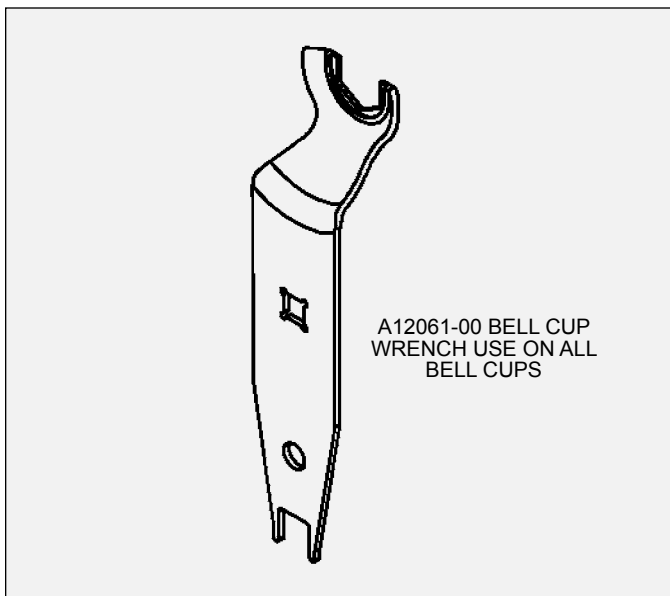

Bell Cup Wrench

NOTE

➤ Bell Cups: 10-15 lbs•in (1.13-1.69 Nm) torque.

To re-install a cup, position the wrench as shown. Insert a torque wrench into the square in the wrench to apply approximately 10-15 lbs•in (1.13-1.69 Nm) torque. Hold the cup and tighten the torque wrench in a counter-clockwise direction.

Example: A desired true torque is desired using a 9-inch effective length torque wrench. Wrench offset is 3-inches.

$L = 9\text{-inches}$

$TT = 50\text{lbs}\cdot\text{in}$

$E = 3\text{-inches}$

$DR = \text{is dial reading.}$

$DR = \frac{50}{(9+3)} DR = 37.5 \text{ lbs}\cdot\text{in}$

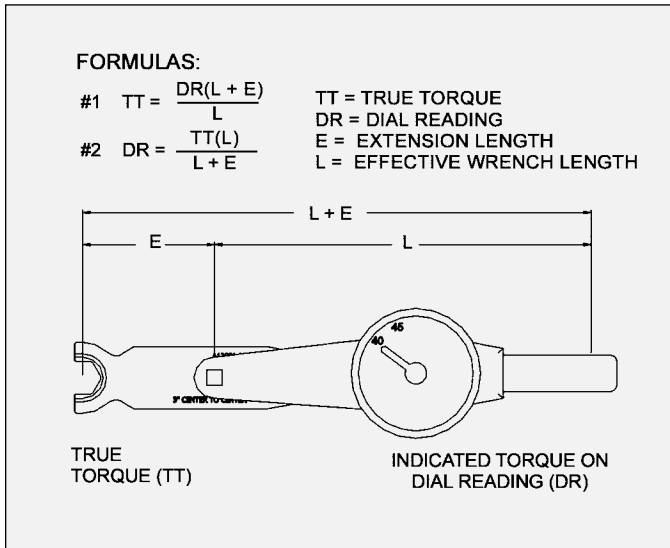

Effective Length Torque Wrench

Bell Cup Insert Removal

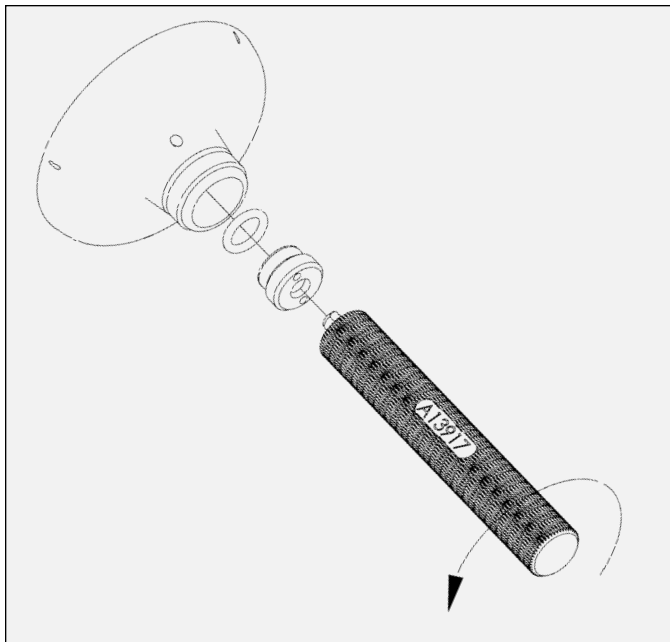

Insert tool into rear of bell cup and engage pins of tool with holes in bell cup insert. Remove by unscrewing counter clockwise. The O-ring is part of the insert.

Re-install O-ring onto insert use petroleum jelly on o-ring to ease insert re-installation tighten insert until stop. Do not over tighten. Do not cross threads.

⚠ CAUTION

➤ Failure to replace a damaged bell cup will cause vibration of the applicator and/or premature turbine failure.

Shroud Removal / Replacement

Removal

Remove five (5) screws from back of applicator. Remove break-away ring and quick disconnect ring. Pull shroud off.

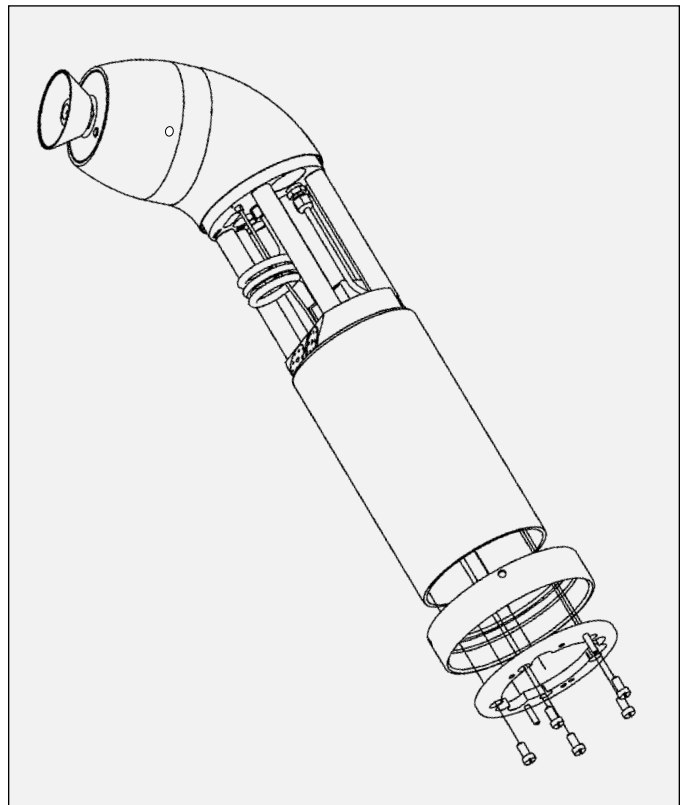

Shroud Removal

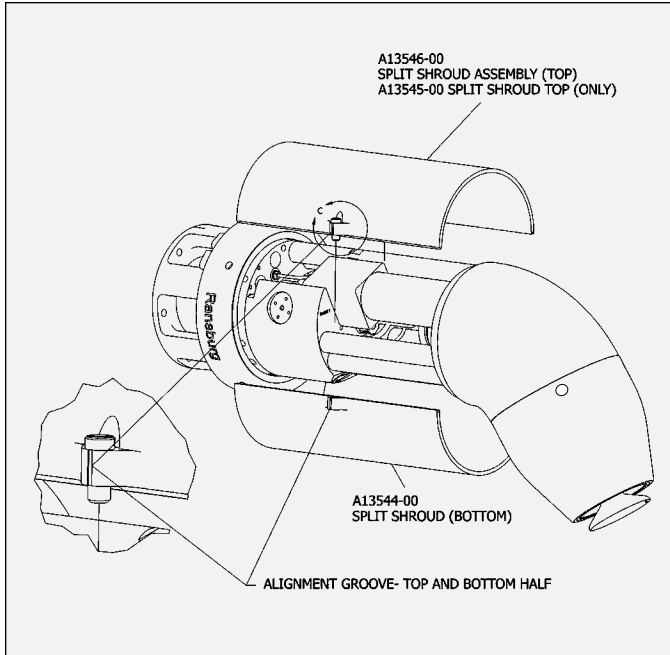

A13559-00 Split Shroud Assembly

Replacement

Push the shroud back into place. A light tap on the end may be required to seat the shroud in position. Slide the quick disconnect ring over the shroud.

Reinstall break-away ring by aligning the four (4) holes with the dowel pins on the recessed face of the rear manifold. Reinstall the five (5) stainless steel screws. Tighten evenly to 15-20 lbs•in (1.69-2.26 Nm) torque. The break-away ring must lie flat against the face of the rear manifold.

Inner/Outer Shape Air Manifold Separation and Removal

Remove the outer shape air ring/shroud (part with the holes on the face) by turning it off with RPM-419-2 wrench in a counter-clockwise direction. Loosen and remove the external cup wash line from the manifold with a 3/16 inch wrench. Loosen set screw (A12253-00) on the shaping air manifold with a 2mm hex key wrench. Remove by turning counter-clockwise. A 1/4-20 threaded screw may be screwed into the cup wash port for additional leverage to remove the part.

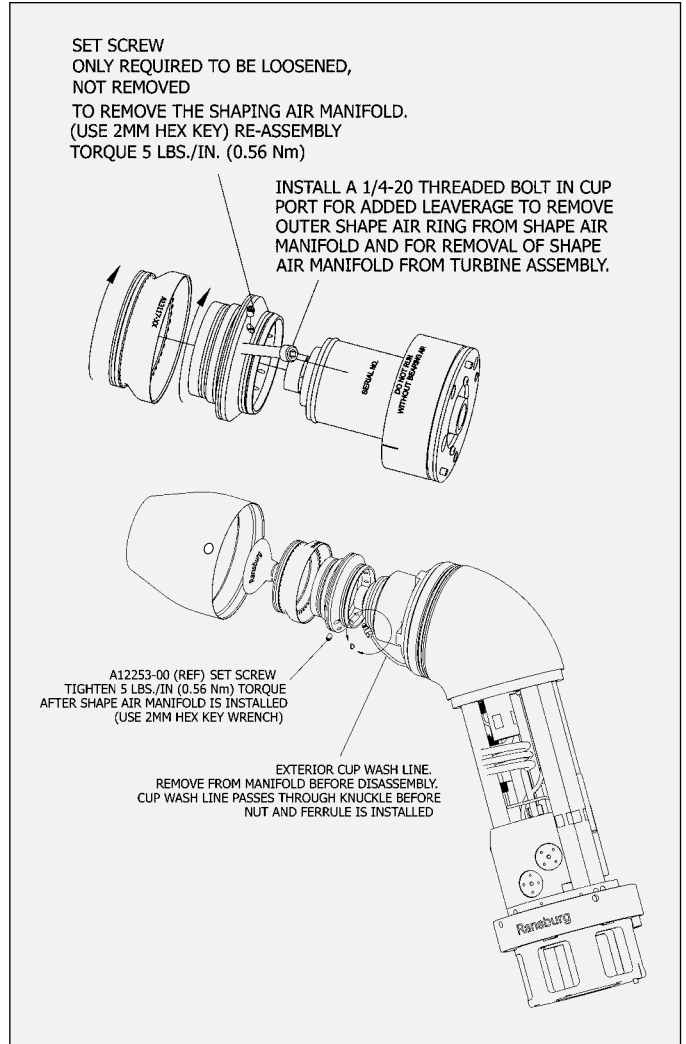

Interior/Exterior Shaping Air Manifold

Shaping Air Manifold Reassembly

(Lightly lubricate all O-rings prior to assembling.) Carefully install the inner shaping air ring onto the turbine threads. Tighten in a clockwise direction until it seats against the turbine. Install set screw and tighten until it stops on the turbine body, then tighten to 5 lbs•in (0.564 Nm) torque to prevent shaping air ring/manifold from rotating. Do not over-tighten! If replacing the solvent tube, install longer fitting into the atomizer body first and tighten with a 3/16" end-wrench. Install fitting into atomizer body until ferrule is seated to a stop. Test by pulling/pushing tube, tighten until no movement then 1/8 turn more. Before installing the other end into the inner shaping air ring, check the position of the 1/4-20 threaded hole. If it is less than 180° from the fitting installed in the atomizer body, you must install a loop to prevent tube from becoming pinched when outer shaping air ring is installed. Do not kink the tube when installing loop.

Turbine Removal / Replacement

Removal

Remove the turbine retaining ring by using the strap wrench (A12088-00), turning the turbine retaining ring in a counter-clockwise direction. Pull the turbine out while rocking it from side to side.

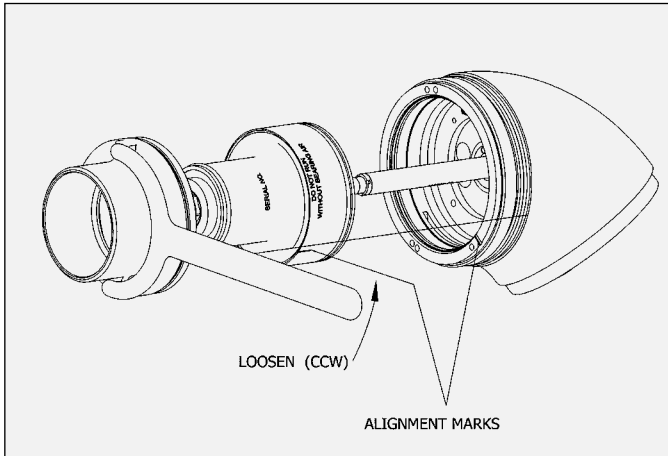

Replacement

Apply a light coating of O-ring lubricant to all the O-rings and the threads of the turbine and turbine retaining ring prior to assembly. Push the turbine down into the cavity in the atomizer body. Align the mark on the turbine with the mark on the atomizer body. Install the turbine retaining ring and o-ring by hand. Use the spanner wrench to tighten an additional 1/8-1/4 turn. (Lightly lubricate O-ring with petroleum jelly.) Check centering of fluid tube. If fluid tube is centered, the turbine is fully seated. If not, check tightness with spanner wrench. If tube is not centered, again remove turbine and check for causes, such as an O-ring fell off, fiber optic not fully installed, foreign material on seating surface, etc. Reinstall and recheck tube centering.

Fluid Tip Removal / Replacement

Removal

To remove the fluid tips, use the tip/tube removal tool (A11229-00). Insert the tool over the tip and engage the four (4) prongs of the tool into the four (4) slots in the tips (see "Fluid Tip Removal" figure).

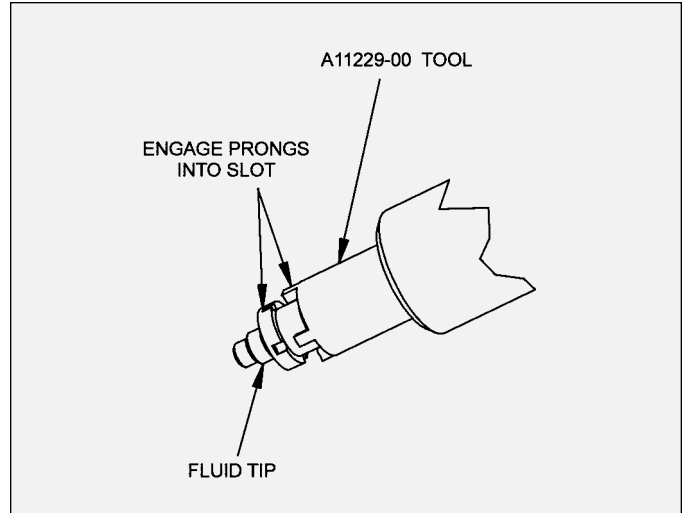

Fluid Tip Removal

NOTE

- To remove, turn the tip **CLOCKWISE**. The thread on the tip is **left hand**.

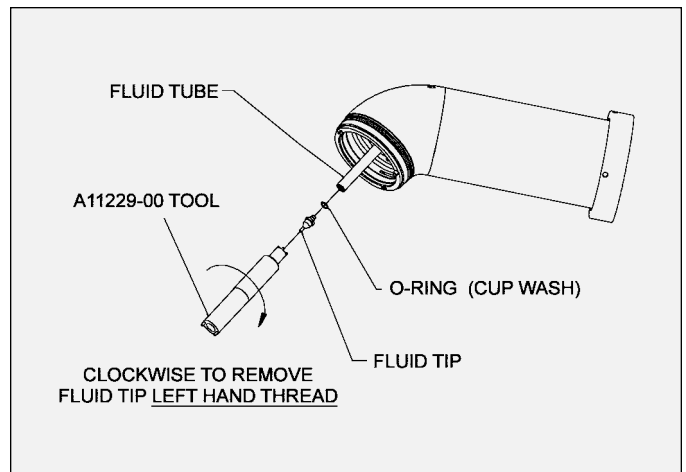

Fluid Tip

The fluid tip may be removed either with the turbine in place, or the turbine off the unit. "Fluid Tip Removal" figure shows removing the tip with the turbine in place.

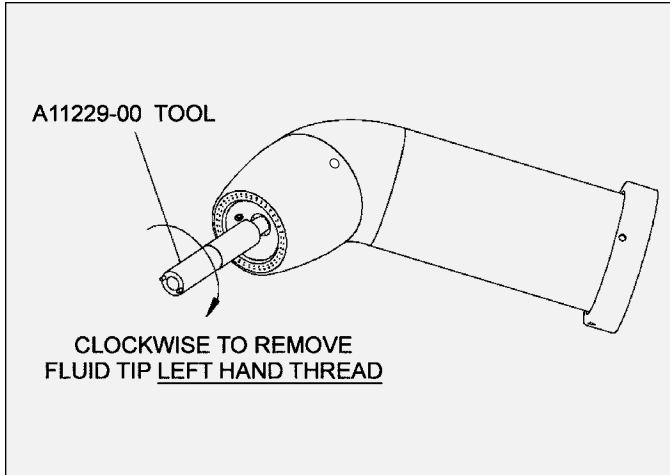

Fluid Tip Removal

This allows removal and replacement of the fluid tip while the applicator is on-line.

Replacement

Ensure the tip openings are fully open and clean. Apply an O-ring lubricant to the O-ring to help hold it in place on the fluid tip. Insert the O-ring into the undercut groove on the tip. Place the tip on the tool and tighten in a **counter-clockwise** direction into the fluid tube. **Do not over-tighten.** There will be a small gap between the flange of the fluid tip and the fluid tube (see “Fluid Tip/Tube Gap” figure). Ensure the O-ring is properly positioned when complete. Tighten to 3-5 lbs•in (.34-.56 Nm) torque.

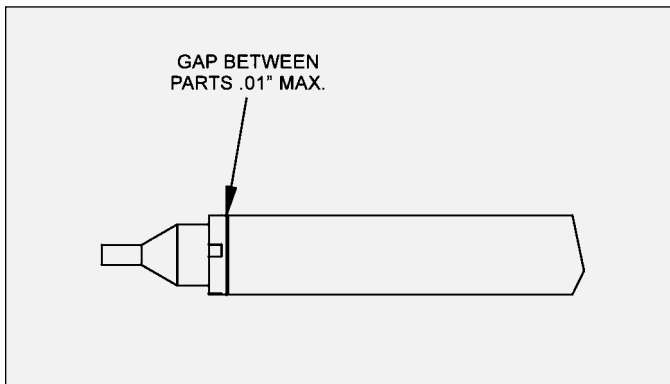

Fluid Tip / Tube Gap

⚠ CAUTION

➤ When removing fluid tip while turbine is still installed, make sure to clean paint or fluid that may leak and run onto the shaft or threads.

Fluid Tube Removal / Replacement

Removal (Turbine Removed)

Using the fluid tip/tube removal tool (A11229-00), place the pinned end of the tool towards the fluid tube retaining nut and engage the pins into the holes. Turn the tool counter-clockwise to remove (see “Fluid Tube Removal” figure).

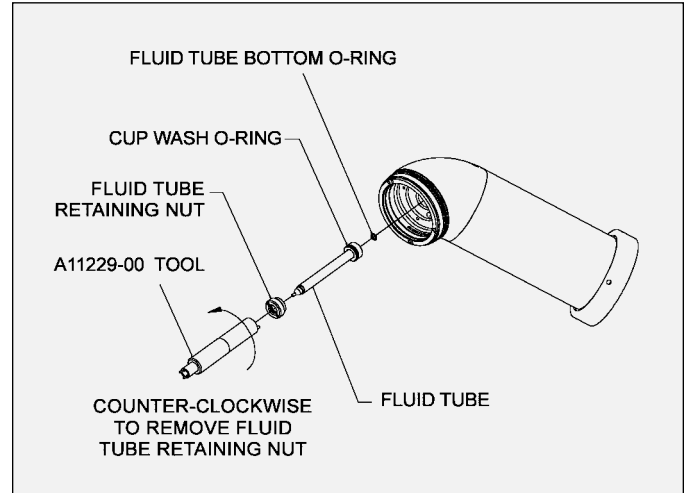

Fluid Tube Removal

Replacement

Lubricate all O-rings with A11545-00 O-ring lubricant. Push the fluid tube into the pocket of the atomizer body. Seat the tube by pushing while rocking the tube from side to side. Install the fluid tube retaining nut over the tube. Tighten the retaining nut firmly tight using the removal tool in a clockwise direction. Tighten to 65-75 lbs./in (7.34-8.47 Nm).

Rear Plate / Rear Manifold / Cascade Removal and Replacement

Removal

Remove the cup wash and the fluid coil fitting from the rear valve manifold. Both are removed by turning counter-clockwise. The ferrule(s) should be retained with the coil and the cup wash line. Remove the five (5) air bolts using a wide bladed screwdriver.

Pull both the rear valve manifold and the rear plate away from the applicator. Loosen the fiber optic and low voltage cascade connector set screws about four turns. Push the cascade connector out of the rear plate towards the front of the applicator, pull the fiber optic cable out. Both the rear plate and the rear valve manifold may now be removed.

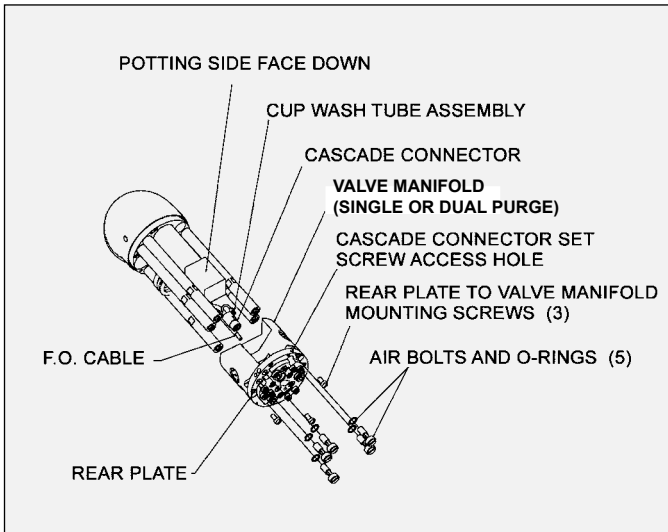

Rear Valve Manifold Removal

By hand, attach the rear plate to the rear valve manifold using the three (3) mounting screws. Do not fully tighten. The rear plate is designed such that it mounts to the rear valve manifold only one way. Pull the assembly into the proper position based on the position of the single air tube and the single hole for the air tube in the rear valve manifold. Pull the coiled tube fitting and ferrules into the port for fluid and tighten clockwise into place. Hand tighten until stop, then tighten 1/2-3/4 turn with a wrench. Attach the cup wash fitting and ferrule in the cup was port and tighten into place. Hand tighten until stop, then tighten 1/8-1/4 turn more with a wrench. Push the Cascade connector into the hole in the rear plate for it. Align the timing mark on the plate with the timing mark on the connector using a 3/32" hex key wrench (see "Rear Plate Alignments" figure).

Cascade Removal / Replacement

Removal

Remove all components, shroud, break-away ring, rear plate, and rear manifold. (See "Rear Plate/Rear Manifold/Cascade Removal Replacement" in the "Maintenance" section.) Pull the cascade straight out of the knuckle.

Replacement

Use a small amount of dielectric grease (LSCH0009) on the end of the spring of the cascade and the wire in the knuckle. Also apply a small amount of grease into the concentric rings around the spring.

Install the cascade with the potted side of the cascade towards the outside of the applicator. Make sure O-ring is in the groove inside the knuckle labyrinth area.

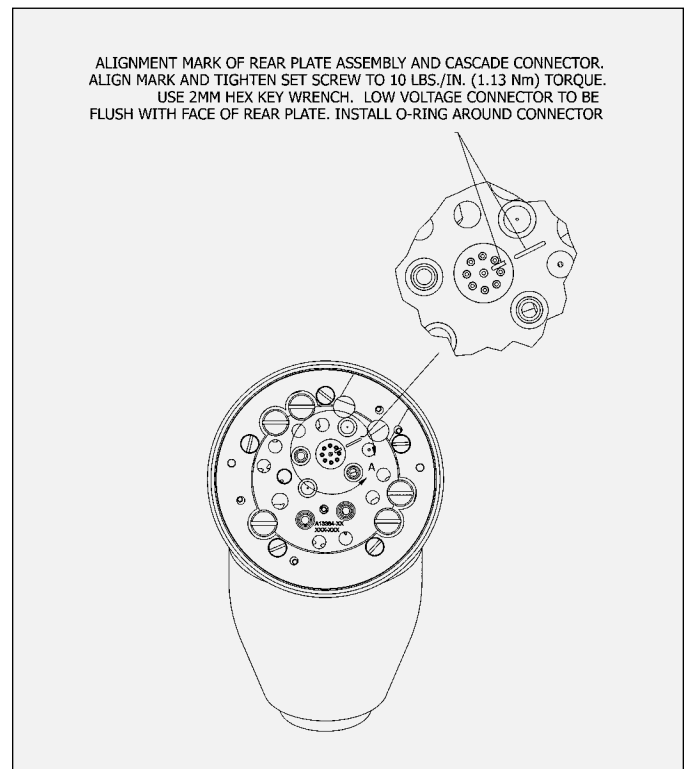
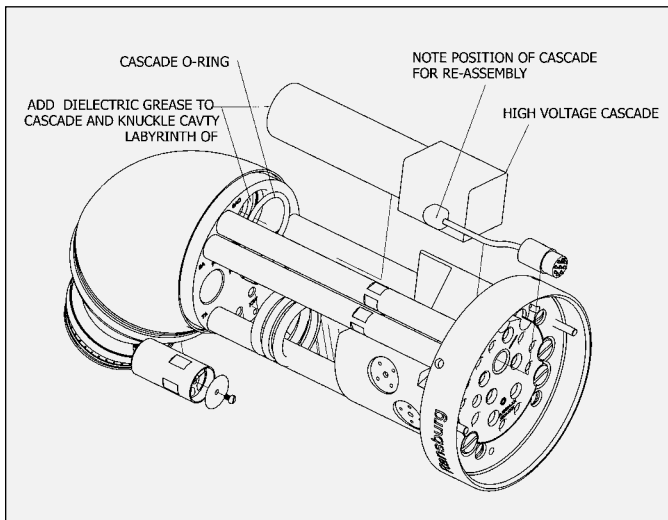

Rear Plate Alignments

Tighten the set screw in place. Tighten to 10 lbs•in (1.13 Nm) torque. Align the flat of the fiber optic cable perpendicular to the set screw. Tighten the set screw with a 3/16" hex key wrench. Tighten to 10 lbs•in (1.13 Nm) torque. Install the five (5) air bolts by hand. Tighten each bolt in a circular pattern. Tighten the three (3) rear plate mounting screws using a 3/16" hex key wrench, 15 lbs•in torque (1.70 Nm).

Rear Manifold Removal / Replacement

Removal

Remove the rear manifold from the applicator (see “Cascade Removal/Replacement” in the “Maintenance” section).

Using the valve removal tool (A11922-00), engage the four (4) pins on the tool to the corresponding four (4) hole pattern in the top of the valve. Using a 1/2” (13mm) socket, end-wrench, or adjustable wrench, remove the valve by turning counter-clockwise.

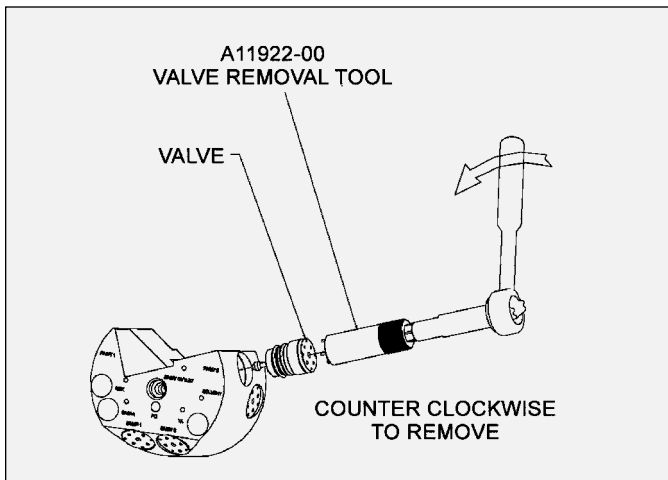

Valve Removal

Using the seat removal tool (A10756-00), insert the smaller hex end into the block to engage the seat female hex. Using a 3/8” (10mm) socket end-wrench, or adjustable wrench, remove the seat by turning counter-clockwise.

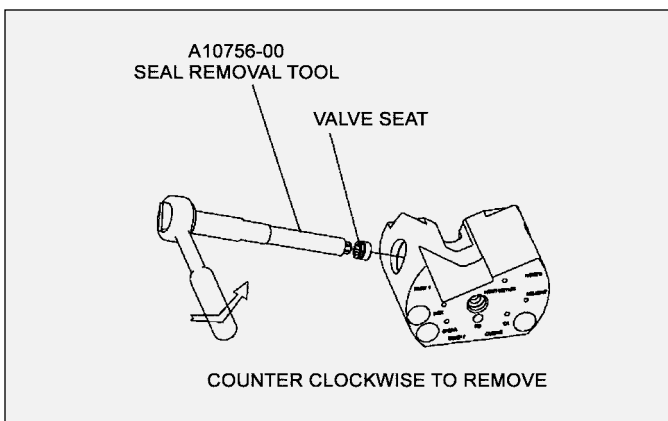

Seat Removal

Valve and Seat Inspection

Inspect the valves and seats for any build-up of materials. Valves should be cleaned with an appropriate cleaning solvent to remove the material on it.

NOTE

- A seat should not be replaced unless there are indications of valve leakage in operation.

Replacement

Lubricate the seat O-ring using a suitable lubricant. By hand, using the seat tool (A10756-00), carefully start the seat into the pocket for the seat.

NOTE

- Carefully start the seat into the pocket. It may be easily cross threaded.

Hand tighten the seat in place. Using a torque wrench with 3/8” (10mm) socket, torque the valve seats to 15-20 lbs•in (1.7-2.3 Nm).

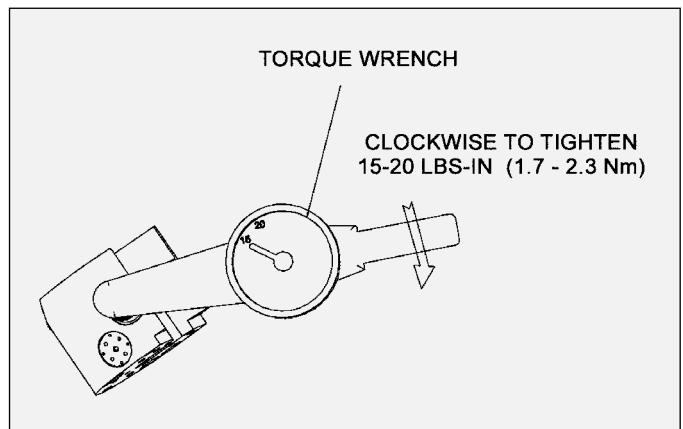

Valve Seat Torque

⚠ CAUTION

- Always use a torque wrench to torque the seats in place. Over-torquing the seats may cause permanent irreparable damage to the rear manifold.

Lubricate the valve O-rings with a suitable O-ring lubricant. By hand, start the threads of the valve clockwise into the pocket. Tighten using a 1/2” (13mm) socket and torque to 15-20 lbs•in (1.7-2.3 Nm) after valve is down.

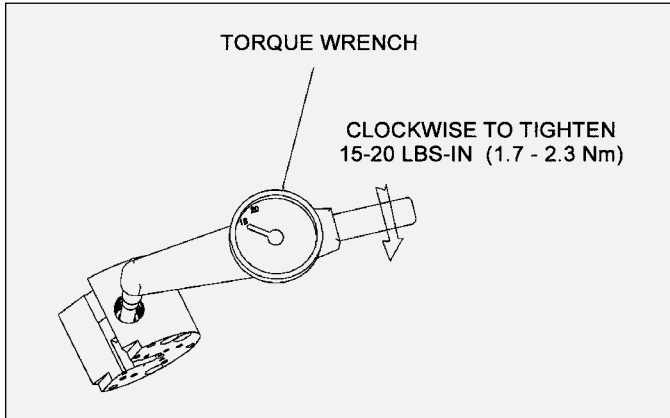

Valve Torque

Support Rod Removal/Replacement

Removal

Using wrench (A11284-00 or A12061-00), remove each of the support rods. Each is removed by turning counter-clockwise.

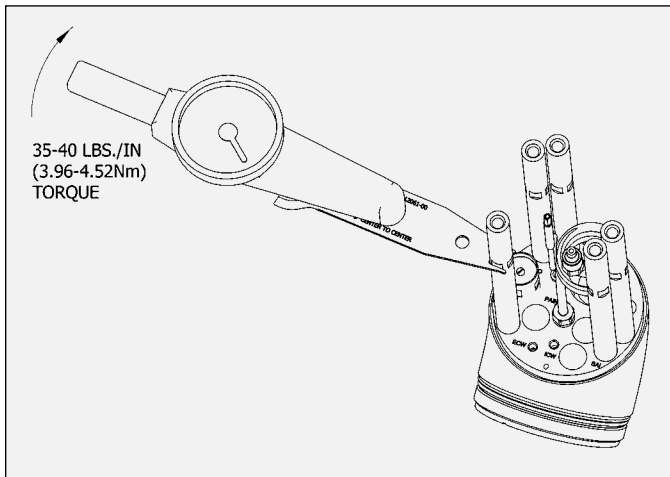

Support Rod Removal

Lubricate all the O-rings on the support tubes with the appropriate lubricant. Install each until the thread has bottomed out in the knuckle using wrench (A11284-00 or A12061-00).

Fiber Optic Cable Removal/ Replacement

Removal

From the turbine side, loosen the Fiber Optic Transmitter Retaining Nut with the 78279-00 tool. Grasp the exposed Fiber Optic Transmitter and pull sharply. This will disengage the transmitter from the cable assembly. On the back side of the knuckle assembly, depress the collet and pull out the fiber Optic Cable Assembly.

Installation

From the back side of the knuckle assembly, slide the Fiber Optic Cable through the collet and push forward until the fiber optic cable is extending out of the knuckle on the turbine side at least 3 inches (75mm). Remove the black nut from the transmitter assembly and slide onto the black portion of the fiber optic cable. Slide the cable into

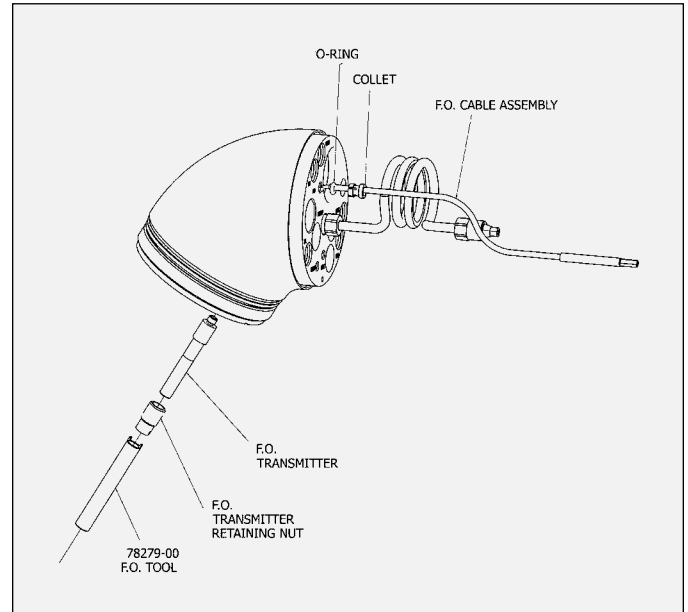

the transmitter assembly and tighten the fiber optic nut tightly. Pull slightly to make sure it is firmly attached. While depressing the collet on the back side of the knuckle, pull the fiber optic cable towards the rear of the applicator. Make sure transmitter is centered in the hole or the cable may come loose. Continue to pull and push the transmitter into place until the transmitter is seated firmly. Re-install the Fiber Optic Retaining Nut with the tool until firmly seated.

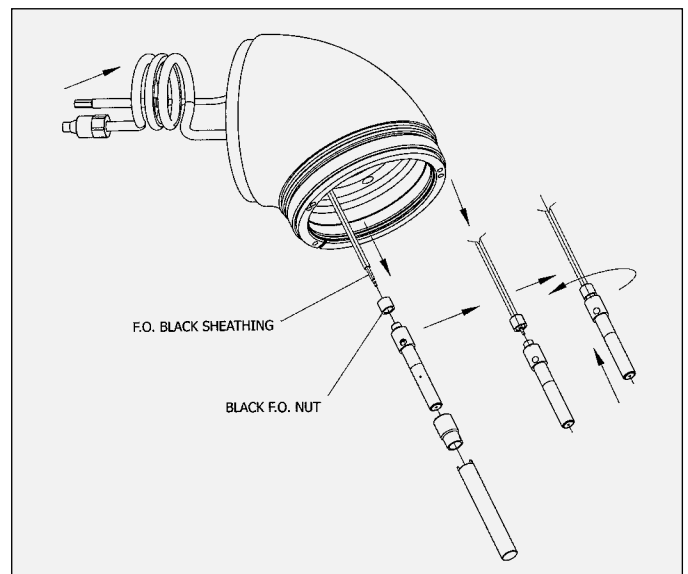

External and Internal Cup Wash Fittings and Tubes

The cup wash fittings at the Shaping Air Manifold and the Rear Plate Assembly are installed with the tapered end of the ferrule away from the fitting. The fittings are tightened into the manifold and the rear plate until snug, then 1/8 more turn. These ferrules are Black in color.

The cup wash fittings and ferrules on the “Y” splitter and the back face of the knuckle assembly are installed with the tapered end of the ferrule towards the fitting. The external cup wash tube goes through the knuckle body to the shaping air manifold. You must install the fitting and ferrule over the tube before passing it through the body. Insert the ferrules and fittings into the appropriate ports and tighten until you hear or feel the fitting click into position. These ferrules are White in color.

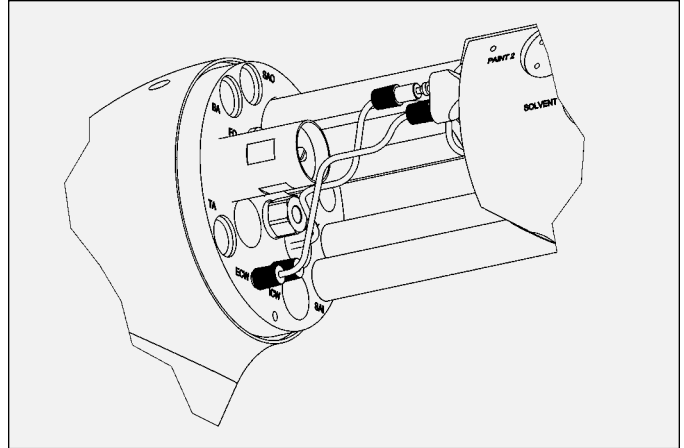

CUP WASH CONNECTIONS FOR DUAL PURGE MANIFOLD

CUP WASH CONNECTIONS FOR SINGLE PURGE MANIFOLD

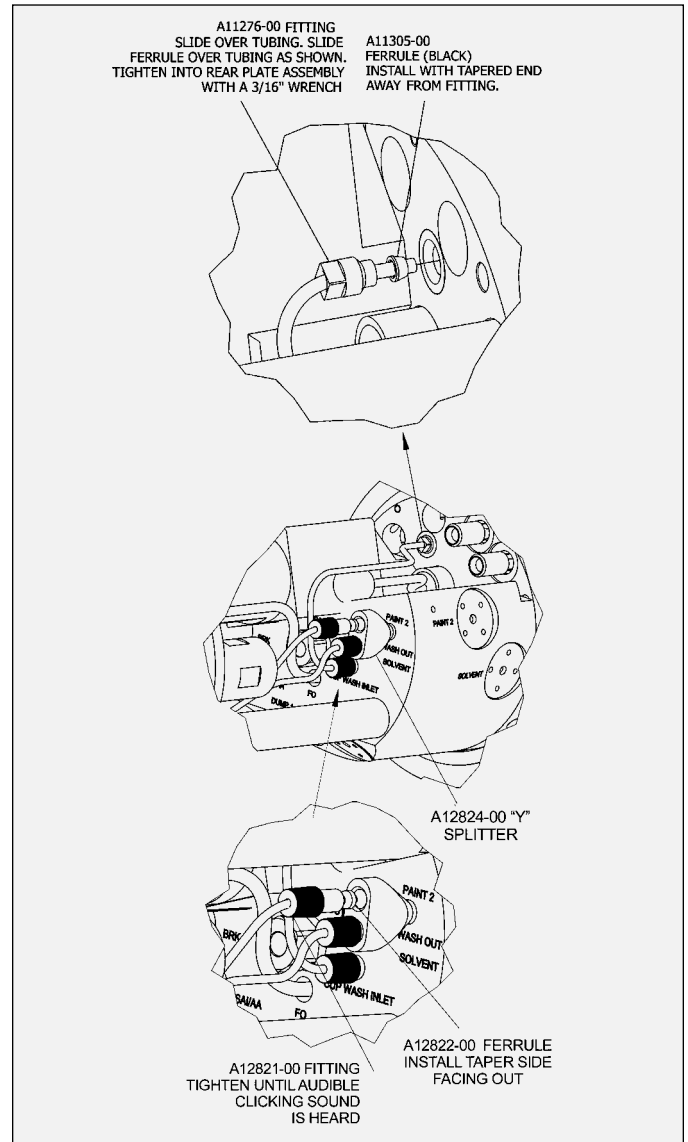
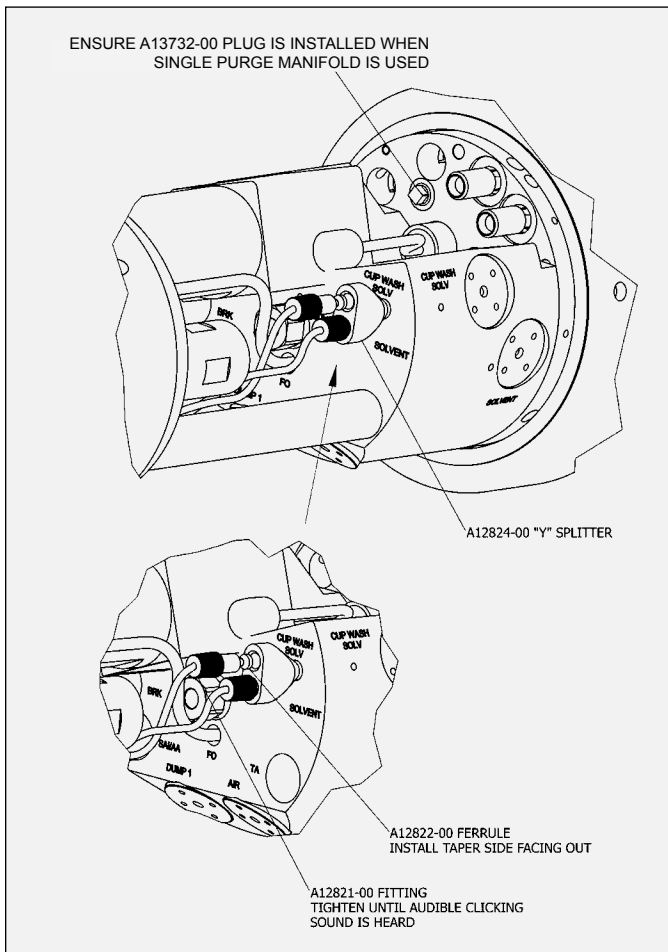

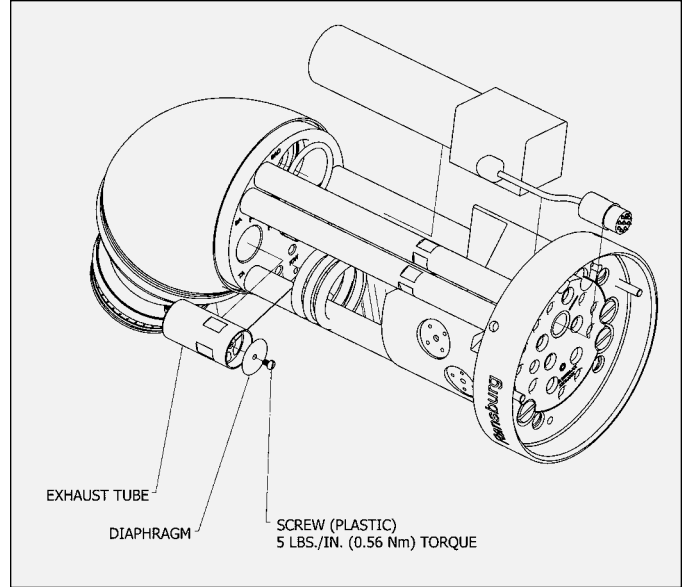
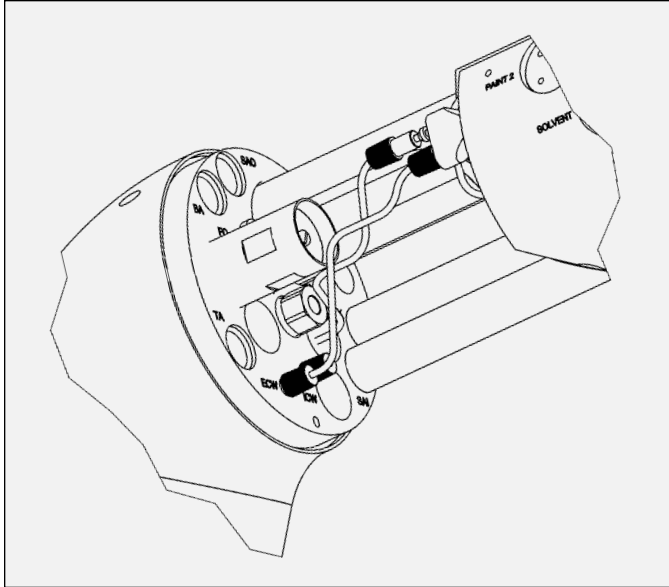

SHAPE AIR MANIFOLD CUP WASH CONNECTION

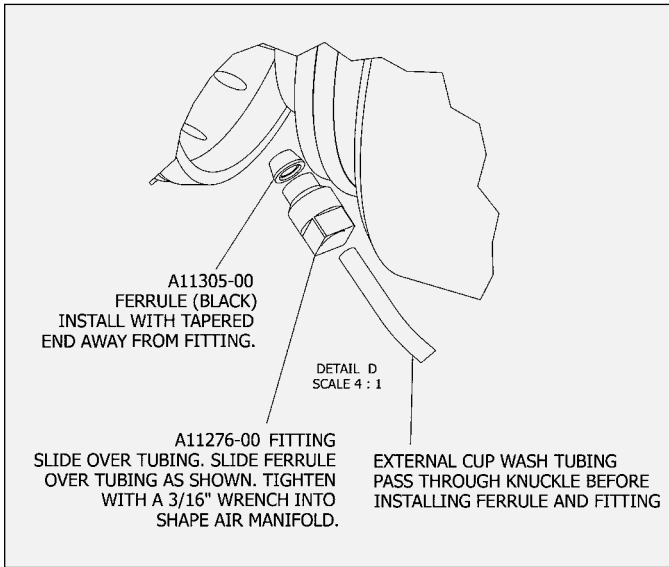

Resistor Assembly (Removal)

The resistor assembly is located on the back side of the knuckle assembly underneath the high voltage cascade. Remove cascade, bend resistor lead straight and remove resistor cap by turning counter-clockwise with tool. Grab resistor lead and pull assembly out.

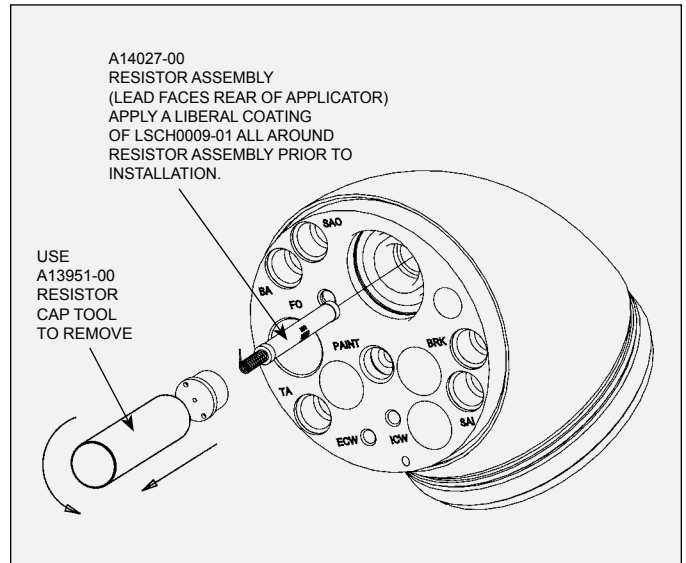

Turbine Exhaust

The turbine exhaust tube is designed to prevent unwanted materials from entering the turbine assembly while providing a free flowing exhaust route. The end on the exhaust tube is protected with a simple diaphragm that closes when the turbine is off but folds out of the way during operation. The diaphragm is held in place with a plastic screw. This diaphragm should be replaced periodically to insure proper operation. Tighten screw to 5 lbs./in. (0.56Nm) torque.

Resistor Installation

Apply a liberal amount of dielectric grease (LSCH0009-00) around entire resistor assembly. Push flat end of assembly in hole first until the bottom of the hole. Place the lead of the resistor through the center hole of the resistor cap. Tighten resistor cap in place with tool (A13951-00) bend over lead and add some dielectric grease to lead and cavity.

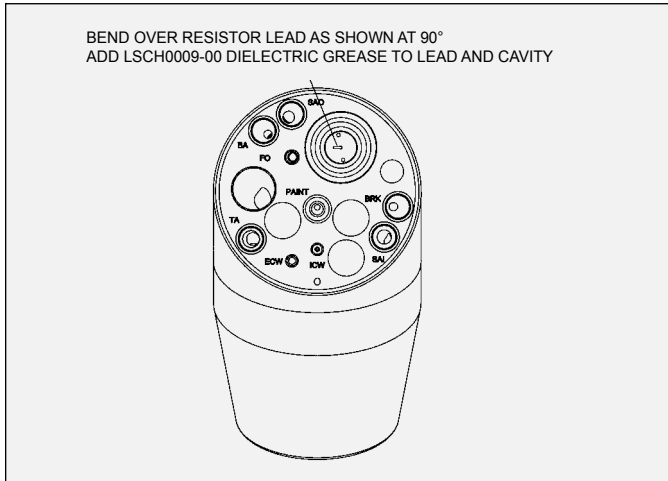

Lightly lubricate O.D. of tubing.



Push receiver fully over tubing and barb assembly.

TUBING BUNDLE ASSEMBLY FITTING INSTALLATION AND TUBING REPAIR

NOTE

1. Petrolatum jell required to aid in installation
2. Screw driver for repair
3. Sharp blade for cutting tubing
4. Nitrile or latex gloves to grip components
5. Adjustable wrench and flat plate for installation aid

To Install:



Install receiver over tube first, then lightly lubricate the beginning of the barb of the fitting. Push fully into tube.

To Remove:



Insert screwdriver into slot.



Cut tube from barb and remove tubing.



Pry apart until receiver is separated from barb and tube assembly.



Cut off damaged tubing and follow installation instructions.

TUBING BUNDLE ASSEMBLY FITTING INSTALLATION AND TUBING REPAIR

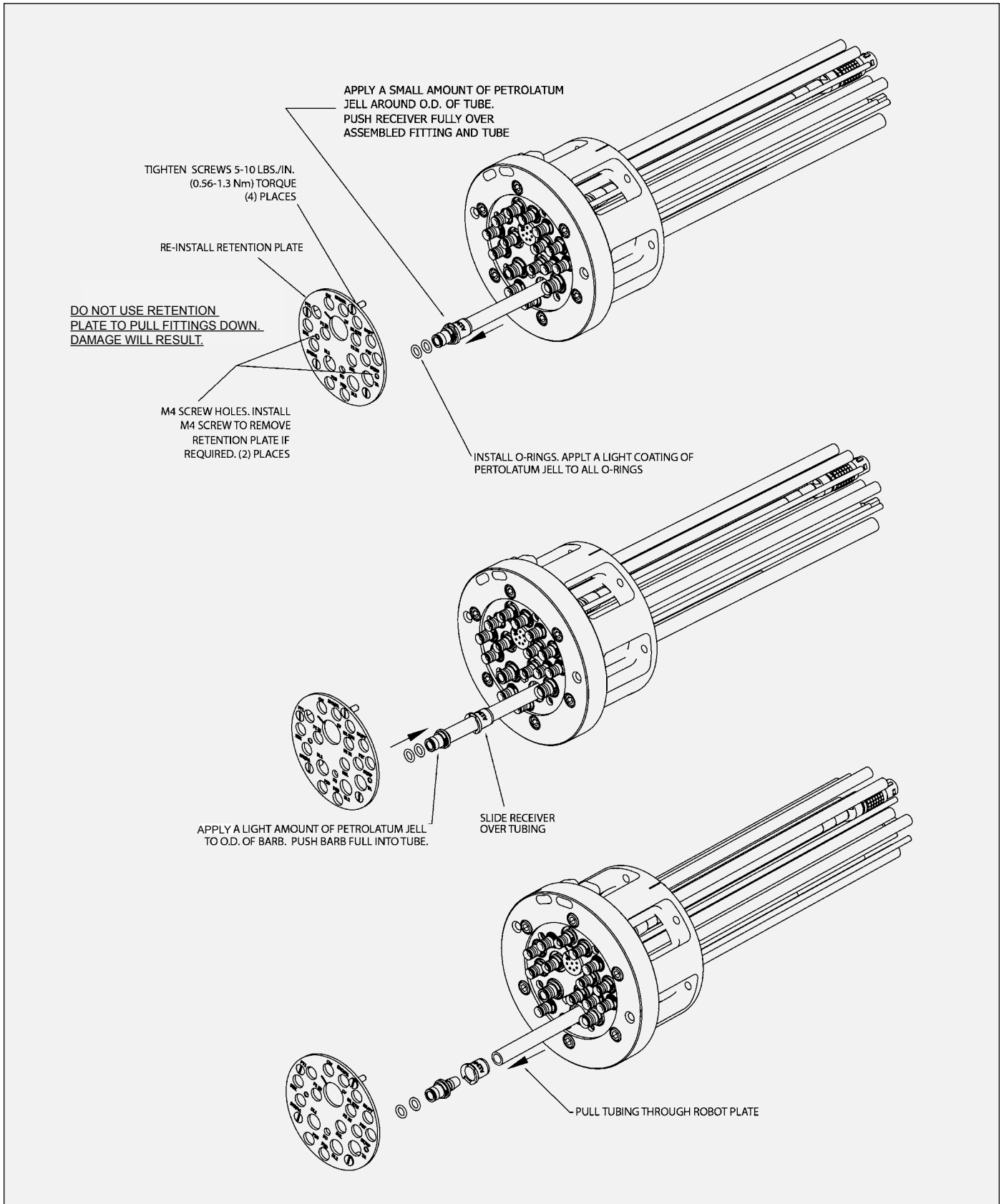

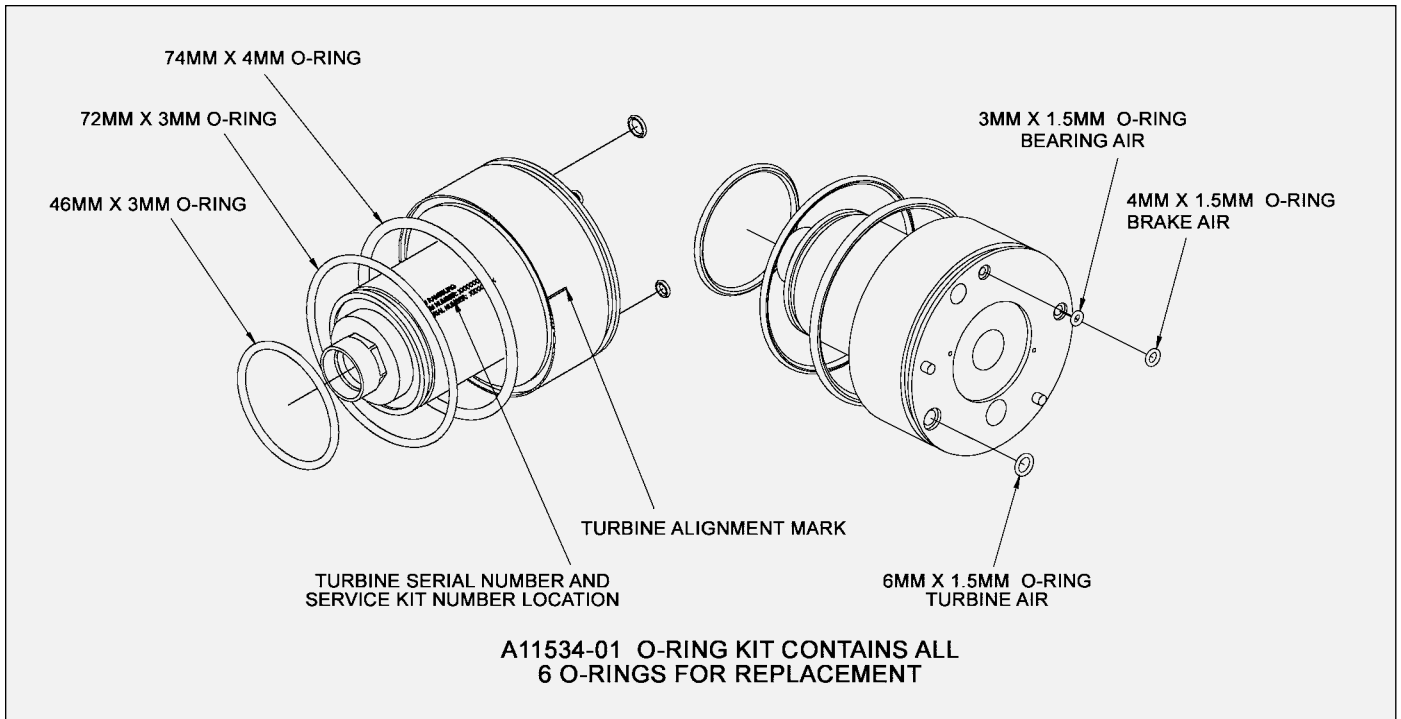

Turbine O-Ring Replacement

- Remove air bearing turbine from the atomizer.
- Remove all exterior O-rings.
- Lightly lubricate all O-rings with A11545 Petrolatum jell before reinstalling.
- O-Ring Kit (A11534-01) contains all required O-rings for replacement.

NOTE

➤ Turbine assemblies are field repairable after the initial one year warranty period. Consult a Ransburg representative for proper manuals and training before attempting any repairs. Any attempt to repair the turbine before the one year warranty period has expired will void the warranty.

TURBINE REBUILD MANUAL

Turbine Part Number	Manual	Description
A12895-01	SI-12-02.1	SILVER SHAFT
A12895-04	SI-13-02	BLACK SHAFT

 **TROUBLESHOOTING GUIDE**

General Problem	Possible Cause	Solution
Bad Spray Pattern	Bell cup damaged	Replace bell cup.
	Low voltage	See “Low or No High Voltage” below.
	Paint lodged in shaping air ring	Disassemble and clean (see “Maintenance” section).
Low or No High Voltage	High current draw	a. Paint resistivity to be .1 MΩ to ∞. b. Replace coiled fluid line.
	Solvent valve is actuated	Remove solvent valve air pilot signal (high voltage must be interlocked with the solvent valve air pilot signal to prevent solvent flow while high voltage is energized).
	Loss of low voltage cable connection between robot and bell plates	a. Remove atomizer and inspect low voltage connections on both plates. Verify alignment marks between connectors and plates and verify that connector face is flush with plate. Verify that set screws are secure, but not too tight, as this will prevent the spring-loaded pins on the robot plate from extending and making contact. b. Faulty low voltage cable.
	Improperly mounted air turbine	Verify correct orientation of air turbine so that high voltage spring makes contact with metal pad on turbine assembly.
	Improper limiting current and voltage settings high voltage parts	To readjust settings, refer to “MicroPak 2e” operating manual.
	Atomizer grounding out (usually indicated by high current draw or by MicroPak 2e over-current fault light)	a. Clean atomizer externally with non-polar solvent. b. Check the atomizer externally with non-polar solvent. c. Check for fluid leaks at quick disconnect mounting (between bell plate and robot plate). d. Check for internal arcing (usually indicated by internal sparking sounds). e. Make sure cascade low voltage connection is properly shielded.

(Continued On Next Page)



TROUBLESHOOTING GUIDE (Cont.)

General Problem	Possible Cause	Solution
Low or No High Voltage (Cont.)	Faulty low voltage connections (Usually indicated by MicroPak 2e feedback fault light)	Make sure quick disconnect electrical connection is aligned and clean. a. Check low voltage connection at cascade.
	Faulty high voltage connection	Remove cascade and check continuity between cascade connection and turbine shaft.
	MicroPak 2e or cascade failure	Refer to “MicroPak 2e” service manual for detailed “Troubleshooting Guide”.
	Improper color change (i.e., paint or solvent in dump line)	Optimize color change.
Low Transfer Efficiency (or light coverage)	Low or no high voltage	Verify high voltage at bell cup edge. Normally a high voltage setting of 70-90 kV is appropriate for most applications.
	Poor grounding of parts being coated	Verify that parts being coated are properly grounded (the electrical resistance between the part and ground must not exceed 1 megohm).
	Excessive turbine speed	For optimum transfer efficiency and spray pattern control, the bell rotational speed should be set at the minimum required to achieve proper atomization of the coating material.
	Excessive inner/outer shaping air	Shaping air should be set at the minimum volume required to gently direct the spray pattern toward the part being coated. Excessive shaping air will cause some atomized particles to “blow-by” the part or bounce back onto the atomizer.
	Excessive target distance	The recommended target distance is between 6-12 inches (152.4-304.8 Nm) (see “Target Distance” in the “Operation” section of this manual).
	Damage to bell cup	Conductive coating missing from back of bell cup or damage to coating.
No Turbine Air	Turbine drive air not present	Verify supply air pressure.
	Bearing air return signal not present	a. Verify bearing air return signal. b. Increase bearing air supply pressure to 90 psig (± 10 psig) (620.5 ± 68.9 kPa).
	Brake air is activated	Remove brake air signal (turbine air and brake air must be interlocked to prevent both from being used simultaneously).

(Continued On Next Page)



TROUBLESHOOTING GUIDE (Cont.)

General Problem	Possible Cause	Solution
Speed Feedback Fault	Damaged fiber optic cable between robot plate and control panel	Repair or replace the fiber optic cable.
	Connection at robot or bell plate is loose	Reinstall cable and tighten locking set screw.
	Fiber optic transmitter failure	Replace fiber optic transmitter.
	Bad transceiver module	Replace transceiver module.
	Excessive vibration	<ul style="list-style-type: none"> a. Check bell cup for damage. b. Check bell cup for excessive paint buildup. c. Ensure bell cup is tightened properly. d. Check cup and shaft tapers for cleanliness.
No Fluid Flow	Turbine is not rotating	Verify rotation of turbine (the paint valve air pilot must be interlocked with the turbine speed feed back signal to ensure that paint does not flow into the air bearing).
	Fluid valve does not actuate	<ul style="list-style-type: none"> a. Verify that air pilot signal is present. b. Fluid valve air pilot signal is too low. Increase air pressure to 70 psig (482.6 kPa) minimum. c. Replace fluid valve.
	Clogged fluid tube	Remove and inspect fluid tube.
Continuous Fluid Flow	Fluid valve open	<ul style="list-style-type: none"> a. Remove air pilot signal. b. If still open, replace fluid valve.
	Fluid valve seat damaged or worn	Inspect and retighten
Uncontrollable Fluid Flow	Insufficient back pressure to fluid regulator	Replace fluid tube with the next smaller inner diameter size.
	Fluid regulator does not control flow (system)	Disassemble fluid regulator and inspect for paint and solvent.
Fluid and/or Air Leakage Between the Robot and Bell Manifold Plates	Atomizer mounting nut is loose	Tighten mounting ring.
	O-ring is missing.	Install O-ring.
	O-ring is damaged	Visually inspect for damage and replace.

(Continued On Next Page)



TROUBLESHOOTING GUIDE (Cont.)

General Problem	Possible Cause	Solution
Fluid Leakage In Fluid Manifold or Bell Plate	O-ring is damaged	Replace O-ring.
	Outer diameter of tubing coil is damaged	Inspect tubing coil for scratches and replace if damaged.
Fluid Leakage Around Fluid Valve	O-ring is damaged	Replace O-ring(s).
	Outer diameter of tubing coil is damaged	Inspect tubing coil for scratches and replace if damaged.
Turbine Cannot Attain Desired Speed	Excessive vibration	<ul style="list-style-type: none"> a. Check bell cup for damage. b. Check bell cup for excessive paint buildup. c. Bell cup loose - tighten to proper torque. d. Poor turbine air pressure - plant air. e. Have manufacturing check bell cup balance.
	Low or no bearing air	<ul style="list-style-type: none"> a. Check bearing air pressure (minimum 80 psi) (551.6 kPa). b. Check filters for contamination. c. Check for bent or damaged bearing air line. d. Poor turbine air pressure - plant air. e. Damaged speed control.
	Loss of fiber optic/no feed	Damaged fiber optic sensor, bad cable, too many splices. Maximum three (3) splices permitted.
Damaged Bell Cup	Excessive speed	Maximum rated speed: 55,000 RPM
	Collision with target	Replace bell cup

PARTS IDENTIFICATION

RMA-550 ROTARY ATOMIZER MODEL IDENTIFICATION

When ordering, use A13852-ABCDEFGHIJ as indicated by Tables A, B, C, D, E, F, G, H and J.
Ten (10) digits must follow the basic part number. For Example:

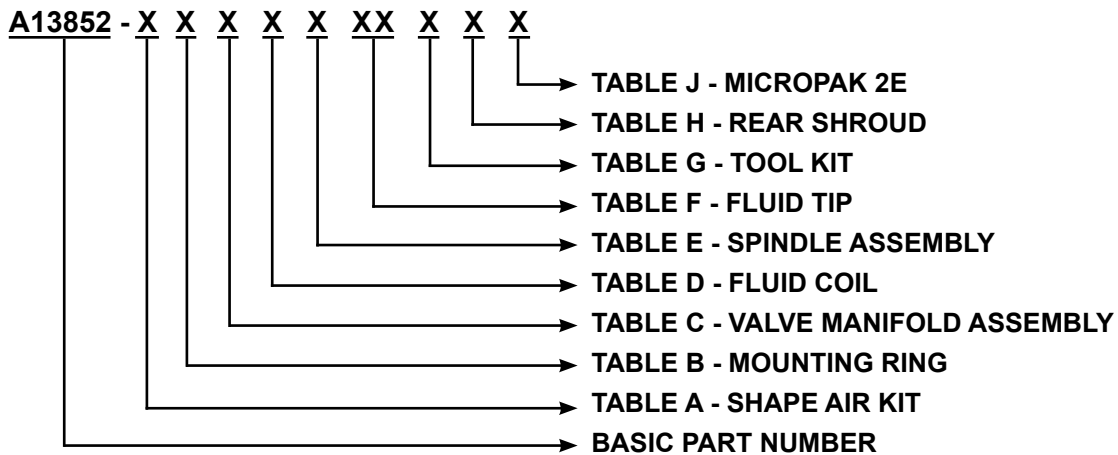

TABLE "A" - SHAPE AIR KITS

Dash No.	A	Description
1	A12874-07	SINGLE SHAPE AIR
2	A12874-10	DUAL SHAPE AIR

TABLE "B" - MOUNTING RING

Dash No.	A	Description
1	A13455-04	PLASTIC WITH SKIRT EXTENSION - BLACK
2	A11201-03	STAINLESS STEEL

TABLE "C" - VALVE MANIFOLD ASSEMBLY

Dash #	"D"	"M"	"N"	"P"	"Q"	"R"	"S"	Description
1	A13729-00	4	4	27"	1	1	1	SINGLE PURGE/INTEGRATED CUP WASH VALVES
2	A13540-00	5	5	39 1/4"	0	2	2	DUAL PURGE

TABLE "D" - FLUID COIL

Dash No.	"D"	Description
1	77531-00	.25 O.D. X .125 I.D. FOR HIGHLY RESISTIVE MATERIALS
2	77517-00	.25 O.D. X .170 I.D. FOR CONDUCTIVE MATERIALS
3	78450-00	.25 O.D. X .125 I.D. FOR HIGHLY CONDUCTIVE MATERIALS

TABLE "E" - SPINDLE ASSEMBLY

Dash No.	"E"	Description
1	A12895-01	SILVER SHAFT
2	A12895-04	BLACK SHAFT

TABLE "F" - FLUID TIP

Dash No.	"G"	Description
01	A13827-01	.028/7MM OPENING
02	A13827-02	.035/9MM OPENING
03	A13827-03	.039/1.0MM OPENING
04	A13827-04	.043/1.1MM OPENING
05	A13827-05	.047/1.2MM OPENING
06	A13827-06	.051/1.3MM OPENING
07	A13827-07	.062/1.6MM OPENING

TABLE "G" - TOOL KIT

Dash No.	"G"	Tools Included
0	NONE	NONE
1	A13926-00	76772-01, A12088-00, A11229-00, A12061-00, 78279-00, A10766-00, LSCH0009-00, A13917-00, A11922-00, A13951-00, RPM-419-2

TABLE "H" - REAR SHROUD

Dash No.	"H"	Description
1	A13444-00	ROUND SHROUD/LOGO
2	A13559-01	SPLIT SHROUD

TABLE "J" - MICROPAK 2E

Dash No.	Part Number	Description
0	NONE	NONE
1	A13613-0017140111	MICROPAK 2e DOMESTIC AC INPUT
2	A13613-0017141111	MICROPAK 2e EUROPEAN AC INPUT
3	A13613-0017142111	MICROPAK 2e CHINA AC INPUT

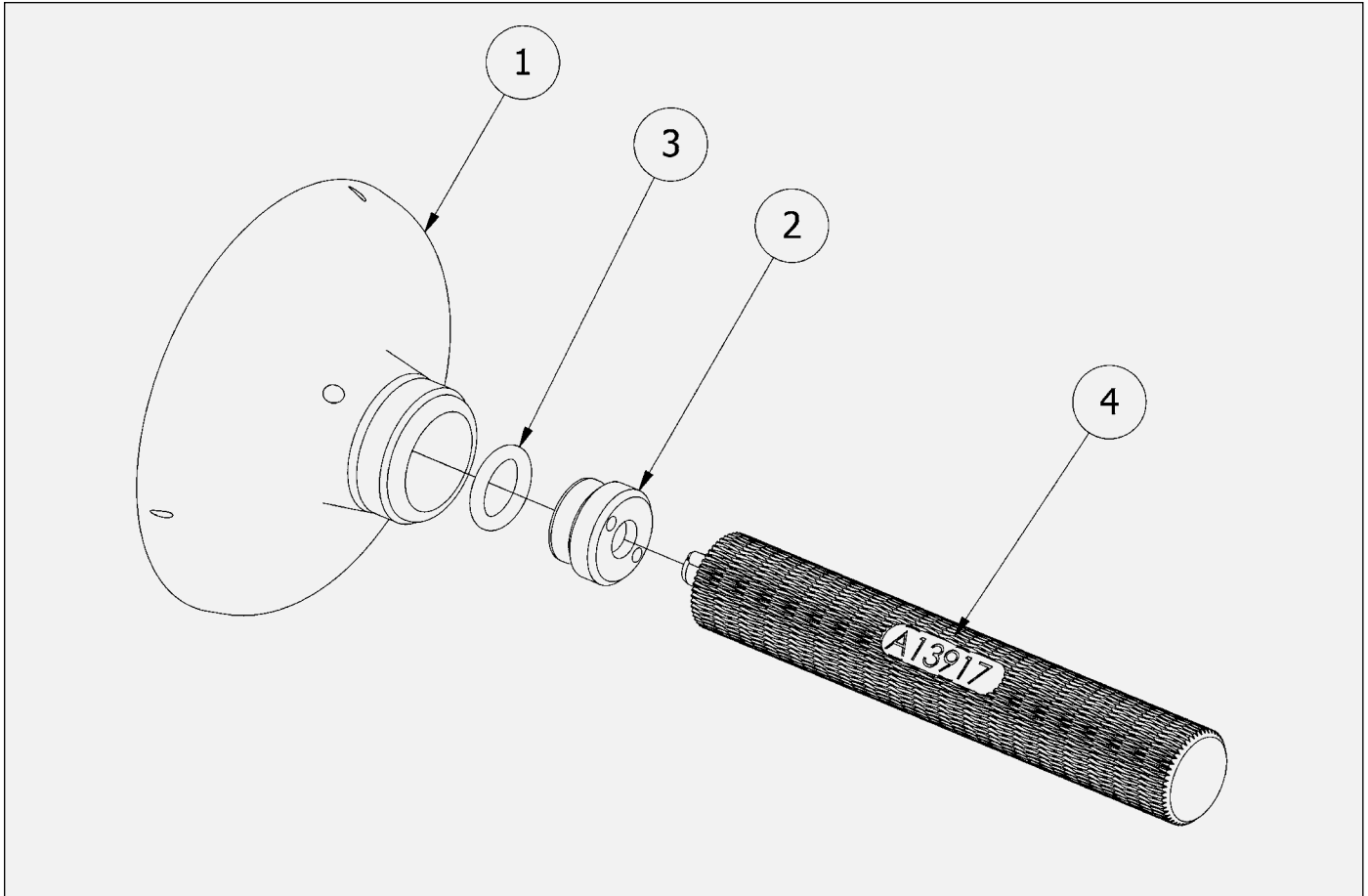

Bell Cup Assembly

BELL CUP ASSEMBLY

Item	Qty	Part Number	Description
1	1	A13904-00	BELL CUP, 57MM PLASTIC
2	1	A13903-00	INSERT
3	1	79001-06	O-RING, SOLVENT PROOF
4	1	A13917-00	INSERT REMOVAL TOOL

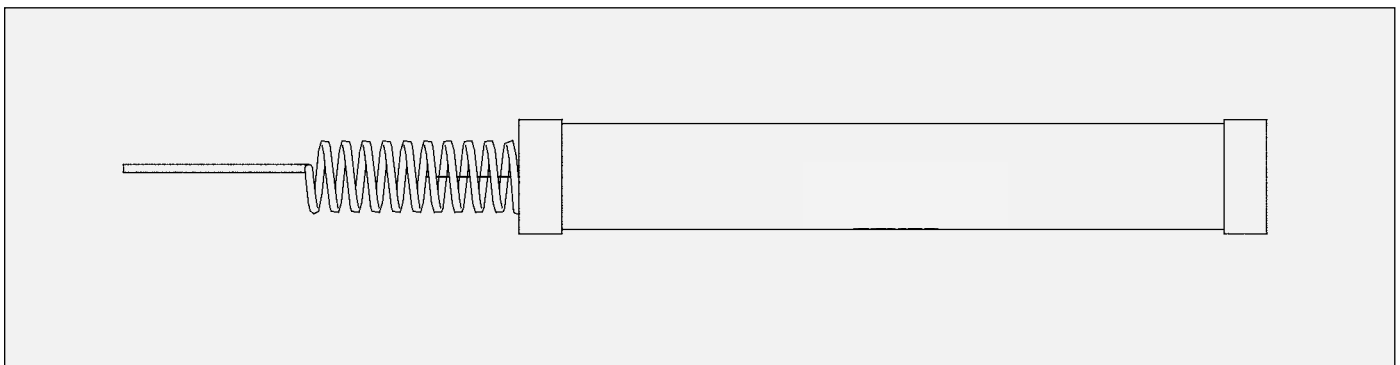

A14027-00 Resistor Assembly

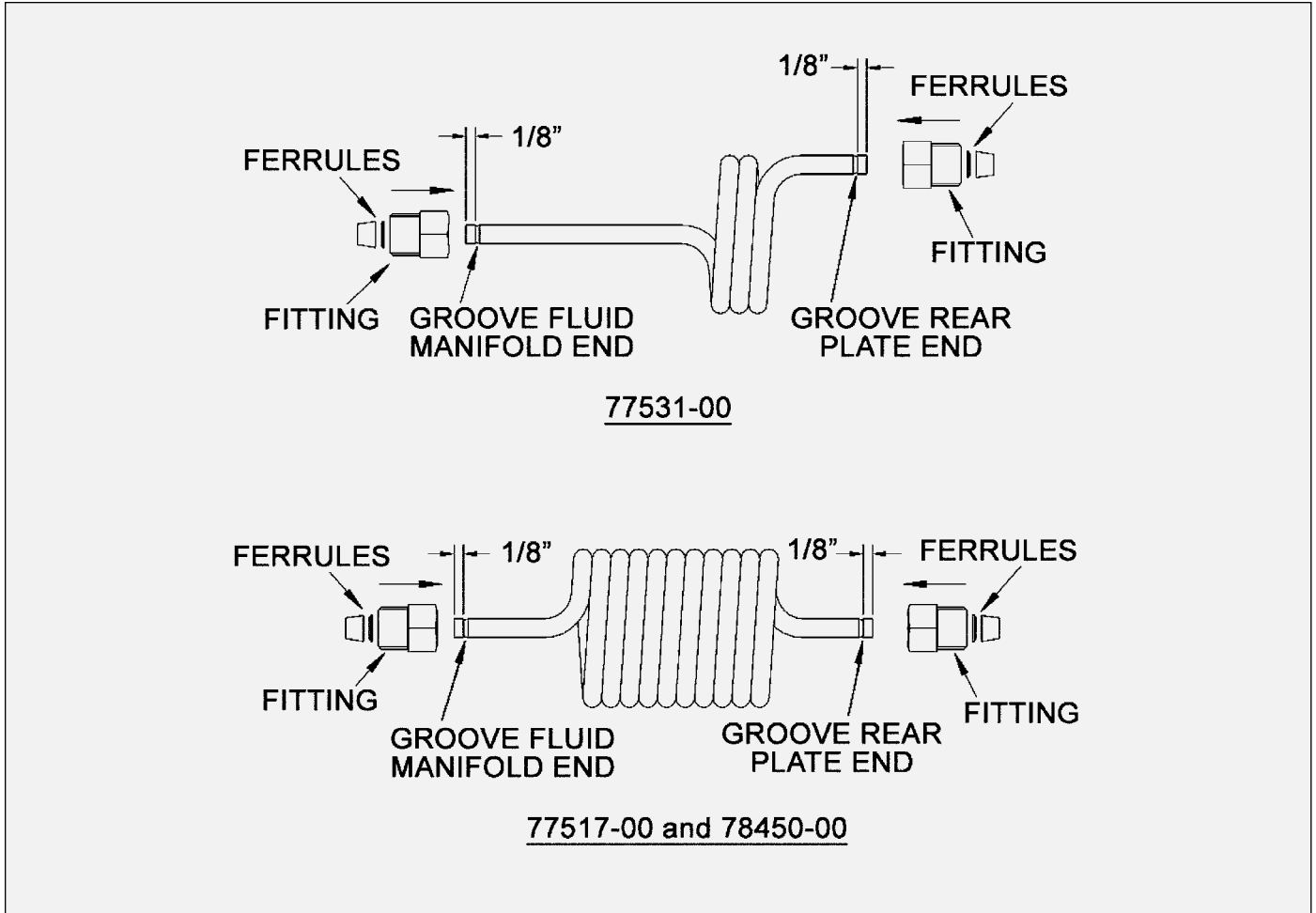

Fluid Coils

Fluid Coils (Separate Sales Parts Only)

If purchasing spare parts, they must be modified as explained.

To ensure proper sealing and holding, the fittings require that the ends of the fluid coils have a groove cut into them as shown. Use groove cutter A11567-00, by sliding the end of the tool over the tubing until it bottoms out. Hold the tubing in one hand and the tool in the other. Make three complete revolutions of the tool on the tubing in the direction of the arrow stamped on the tool. To remove the tool, hold the tube and the main body of the tool with one hand, slide the rear portion of the tool back until it stops. Pull out the tubing from the end of the tool. By pulling back the rear portion of the tool, it relieves the pressure of the cutting edge off of the tubing before sliding it out. Trim off ends to dimensions shown. End should be cut off square.

Slide the fitting and ferrules onto the tube as shown. The tapered ferrule must go past the newly cut grooved to properly lock into place when installed. Install hand tight and then 1/4-1/2 turn more with a 9/16" end wrench or flare nut wrench.

FITTING AND FERRULE REPLACEMENT	
Part No.	Description
78449-00	FLUID FITTINGS
EMF-203-04	FRONT FERRULE
EMF-202-04	REAR FERRULE

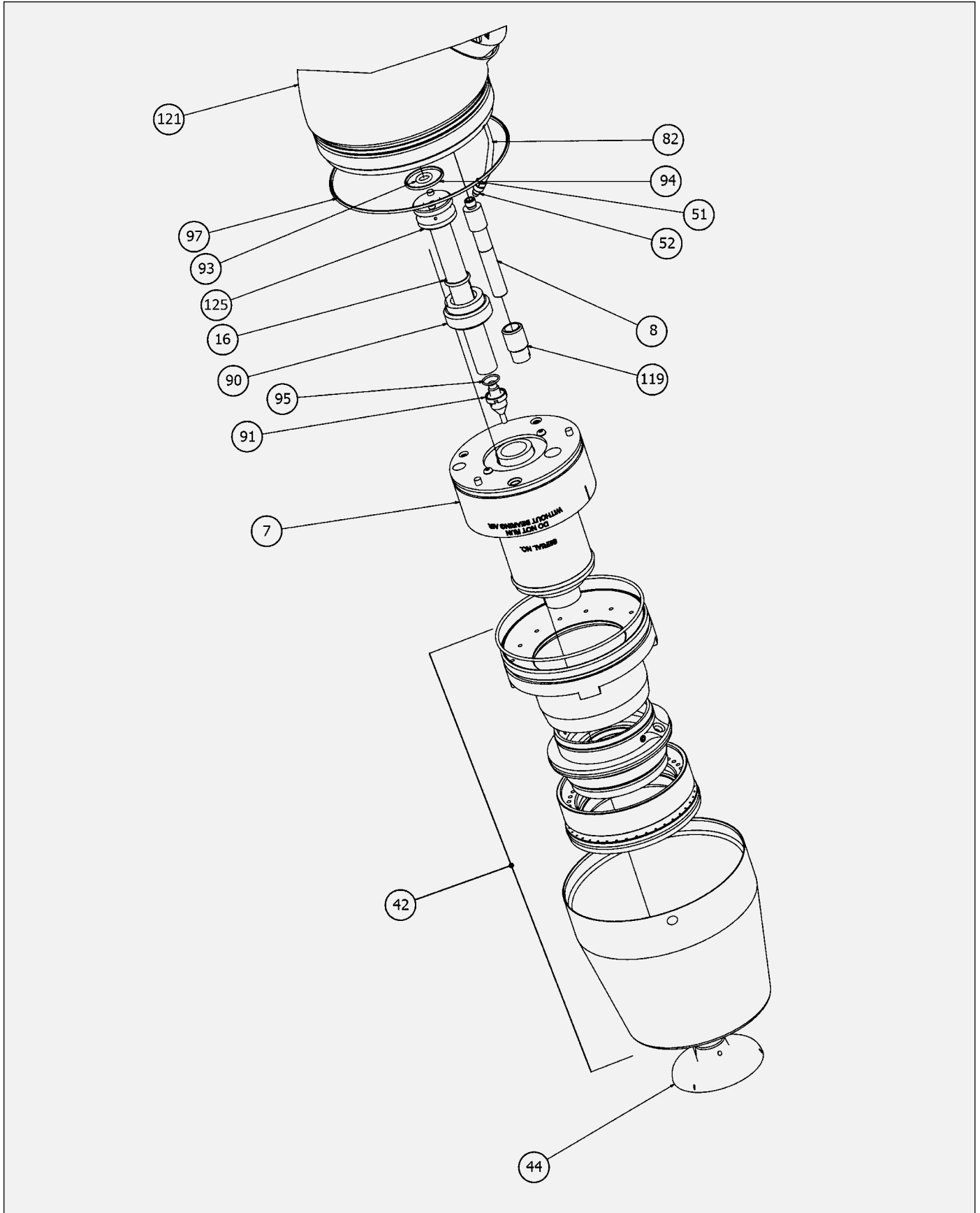

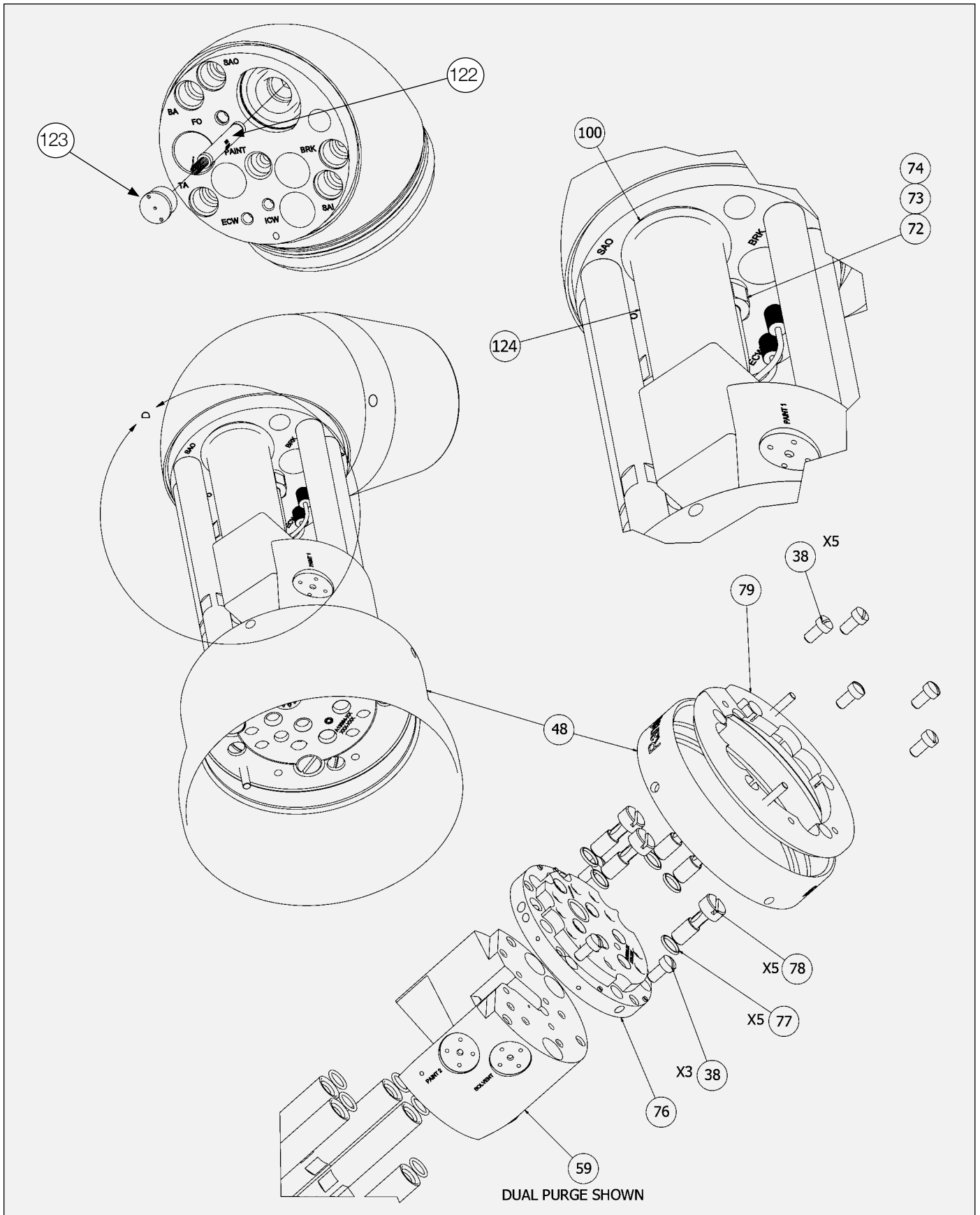

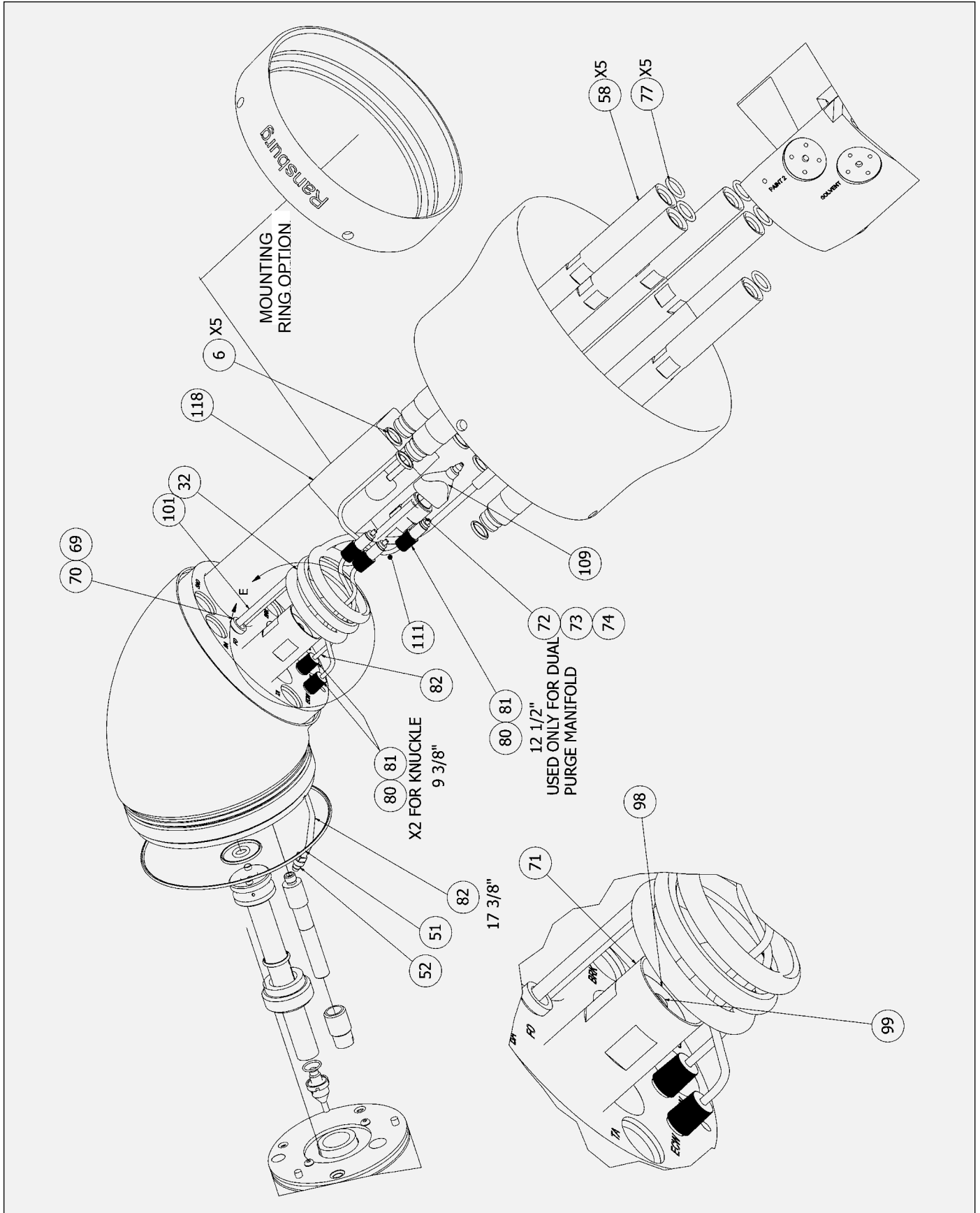

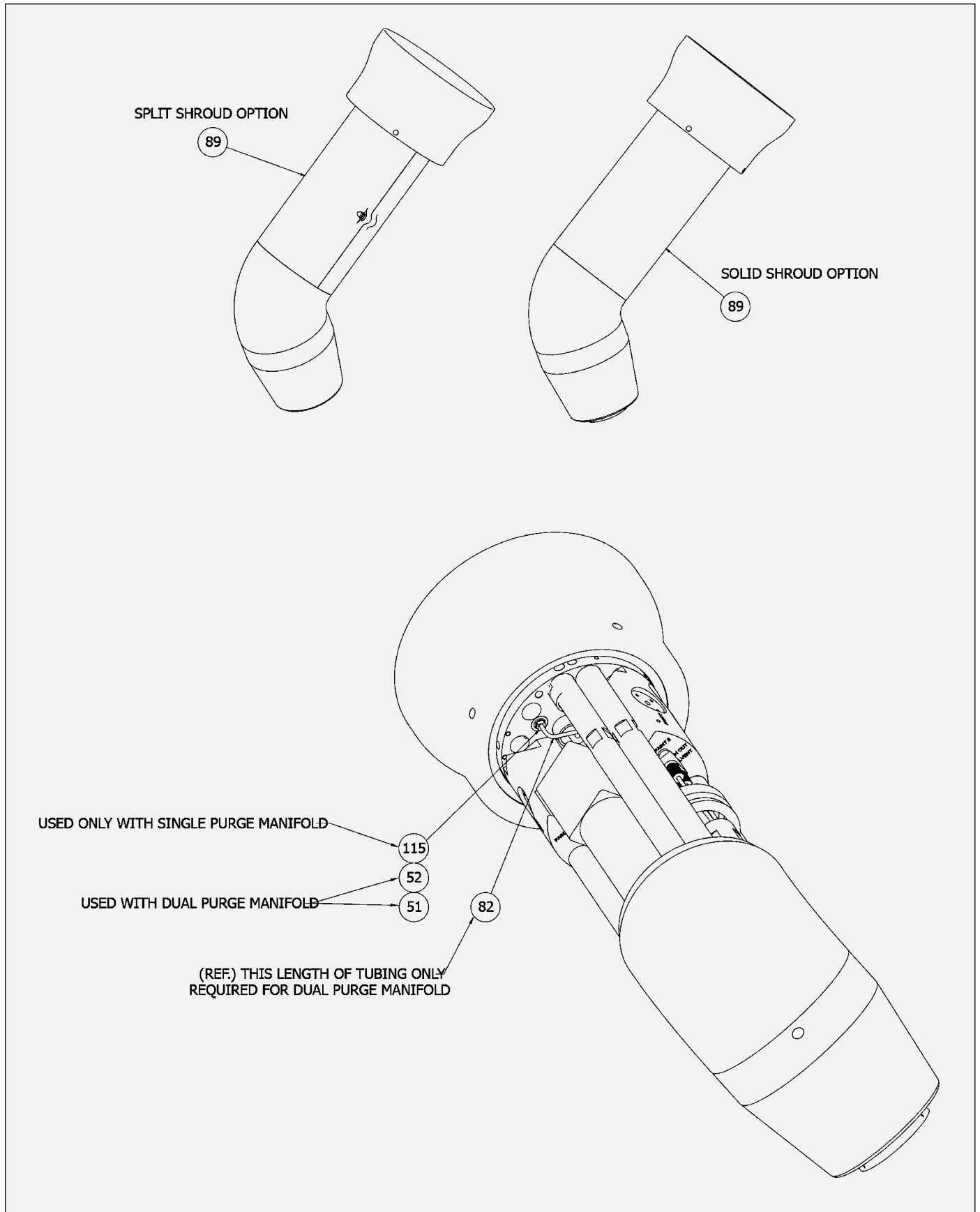

RMA-550 ROTARY ATOMIZER ASSEMBLY

Item	Qty	Part #	Description	
	6	5	79001-14	O-RING, SOLVENT PROOF
	7	1	"E"	SPINDLE
	8	1	75911-00	ASS'Y, FIBER OPTIC TRANSMITTER
	16	1	79001-42	O-RING, SOLVENT PROOF
	32	1	"D"	FLUID COIL
10	38	8	7683-16C	SCREW 1/4-20 STAINLESS STEEL
	42	1	"A"	SHAPING AIR KIT
12	44	1	A13906-00	BELL CUP ASSEMBLY
	48	1	"B"	RING, QUICK DISCONNECT
	51	"S"	A11276-00	FITTING, SOLVENT
	52	"R"	A11305-00	LOWER FERRULE, SOLVENT
8	58	5	A11717-00	ROD, SUPPORT (RMA-303 DUAL PURGE)
	59	1	"C"	ASS'Y., VALVE MANIFOLD, DUAL PURGE
	69	1	79001-30	O-RING, SOLVENT PROOF
	70	1	77516-04	COLLET, 4mm
	71	1	A13322-00	EXHAUST TUBE
	72	2	78449-00	FITTING, FLUID
	73	2	EMF-202-04	FERRULE, BACK 1/4" TUBE
	74	2	EMF-203-04	FERRULE, FRONT 1/4" TUBE
6	76	1	A13430-00	REAR PLATE ASSEMBLY (SINGLE/DUAL PURGE)
	77	10	79001-07	O-RING, SOLVENT PROOF
9	78	5	77508-00	AIRBOLT, MACHINED
	79	1	A13412-00	BREAK AWAY RING (SINGLE/ DUAL PURGE)
	80	"M"	A12822-00	CUP WASH FERRULE
	81	"N"	A12821-00	CUP WASH FITTING
	82	"P"	A11252-01	TUBING, FEP, 3/32 O.D. X 1/16 I.D.
	89	1	"H"	SHROUD
	90	1	A11226-00	RETAINER, FLUID TUBE
5	91	1	"F"	FLUID TIP, PLASTIC
	93	1	79001-40	O-RING, SOLVENT PROOF
	94	1	79001-41	O-RING, SOLVENT PROOF
	95	1	79001-44	O-RING, SOLVENT PROOF
	97	1	79001-22	O-RING
	98	1	A13325-00	DIAPHRAGM
	99	1	A13328-00	SCREW (M3 X 0.5 X 5 NYLON)
	100	1	LSOR0005-18	O-RING, FEP ENCAPSULATED
	101	1	A13542-00	FIBER OPTIC CABLE ASSEMBLY
	105	1	"G"	TOOL KIT (NOT SHOWN)
	106	1	A13975-01	LITERATURE KIT (NOT SHOWN)

(Continued On Next Page)

RMA-550 ROTARY ATOMIZER ASSEMBLY (Cont.)

Item	Qty	Part #	Description
109	1	A12824-00	CUP WASH Y FITTING
115	"Q"	A13732-00	CUP WASH PLUG
119	1	78278-00	NUT, FIBER OPTIC TENSIONING
121	1	A13950-00	KNUCKLE ASSEMBLY (WITH HV SPRING)
122	1	A14027-00	RESISTOR ASSEMBLY
123	1	A13954-00	RESISTOR CAP
124	1	79010-00	CASCADE ASSEMBLY
7 125	1	A13826-00	FLUID TUBE ASSEMBLY
126	1	"J"	MICROPAK 2E

NOTE 1: LUBRICATE ALL O-RINGS WITH PETROLATUM JELL SPARINGLY TO AID IN INSTALLATION.

12 TORQUE BELL CUP TO A FINAL TORQUE ON 10-15LBS/IN. (1.13-1.69 Nm)

10 TIGHTEN SCREWS TO A FINAL TORQUE OF 15-20 LBS/IN. (1.69-2.26 Nm)

9 TIGHTEN AIR BOLT TO A FINAL TORQUE OF 15 LBS/IN. (1.69 Nm)

8 TIGHTEN SUPPORT TUBES TO A FINAL TORQUE OF 10-15 LBS/IN. (1.13-1.69 Nm)

7 TORQUE FLUID TUBE INTO ATOMIZER BODY USING A11229-00 TOOL TO 65-75 LBS/IN. (7.34/8.47 Nm)

6 TORQUE SET SCREW IN REAR PLATE FOR FIBER OPTIC AND LOW VOLTAGE CONNECTOR TO 5-10 LBS/IN. (0.56-1.13 Nm)

5 TORQUE FLUID TIP USING A11229-00 TOOL TO 5-10 LBS/IN. (0,56-1.13 Nm)

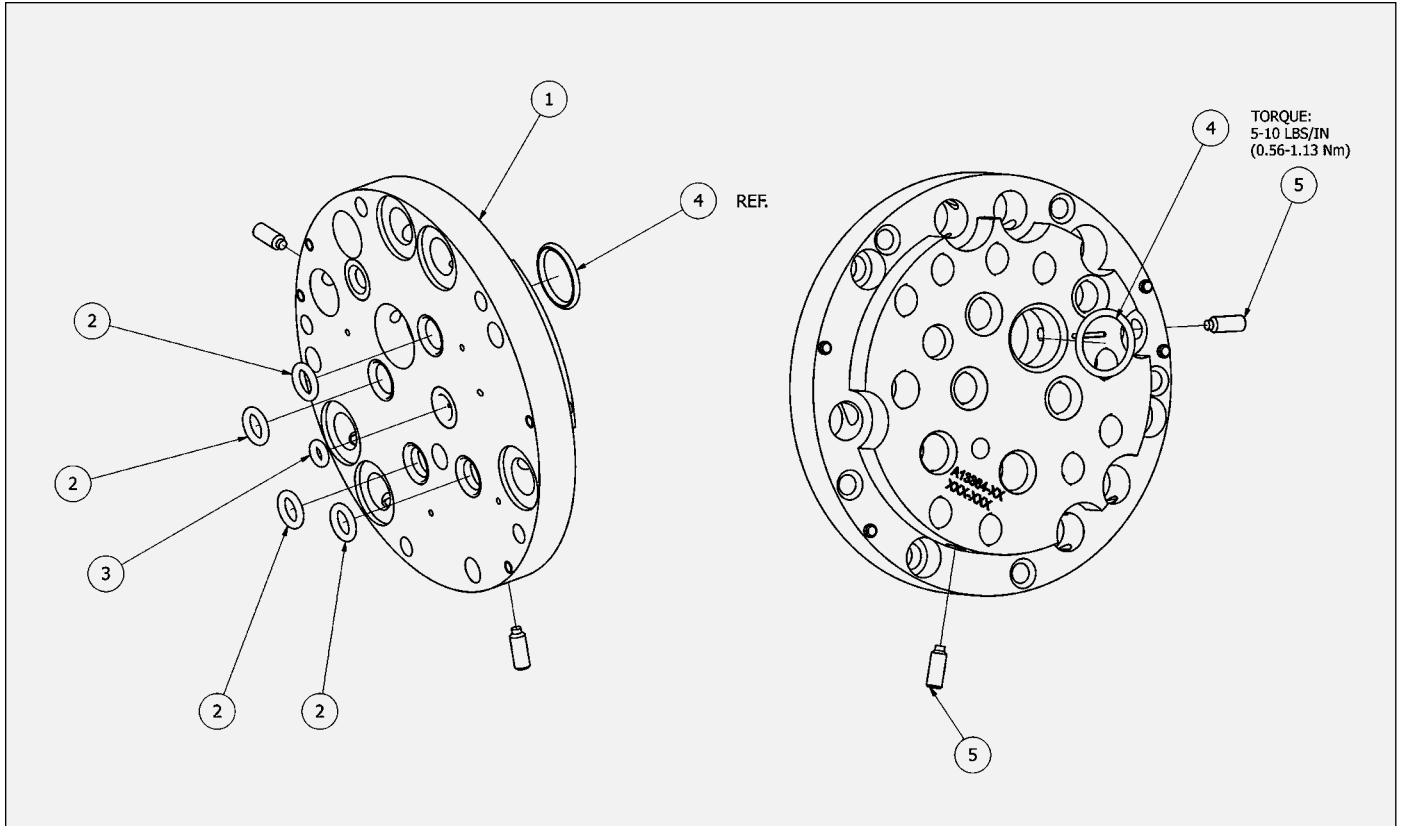

A13430-00 Rear Plate Assembly

A13430-00 REAR PLATE ASSEMBLY - PARTS LIST

Item	Qty	Part #	Description
1	1	A13397-00	Rear Plate Assembly (Single/Dual Purge)
2	4	79001-40	O-Ring, Solvent Proof
3	1	79001-39	O-Ring, Solvent Proof
4	1	79001-09	O-Ring, Solvent Proof
5	2	A13437-00	Set Screw M4 Nylon Point

Note 1: Apply a thin film of A11545 Petrolatum jell to O-rings before assembly

VALVE MANIFOLD ASSEMBLY (Single Purge / Integrated Cup Wash Valves)

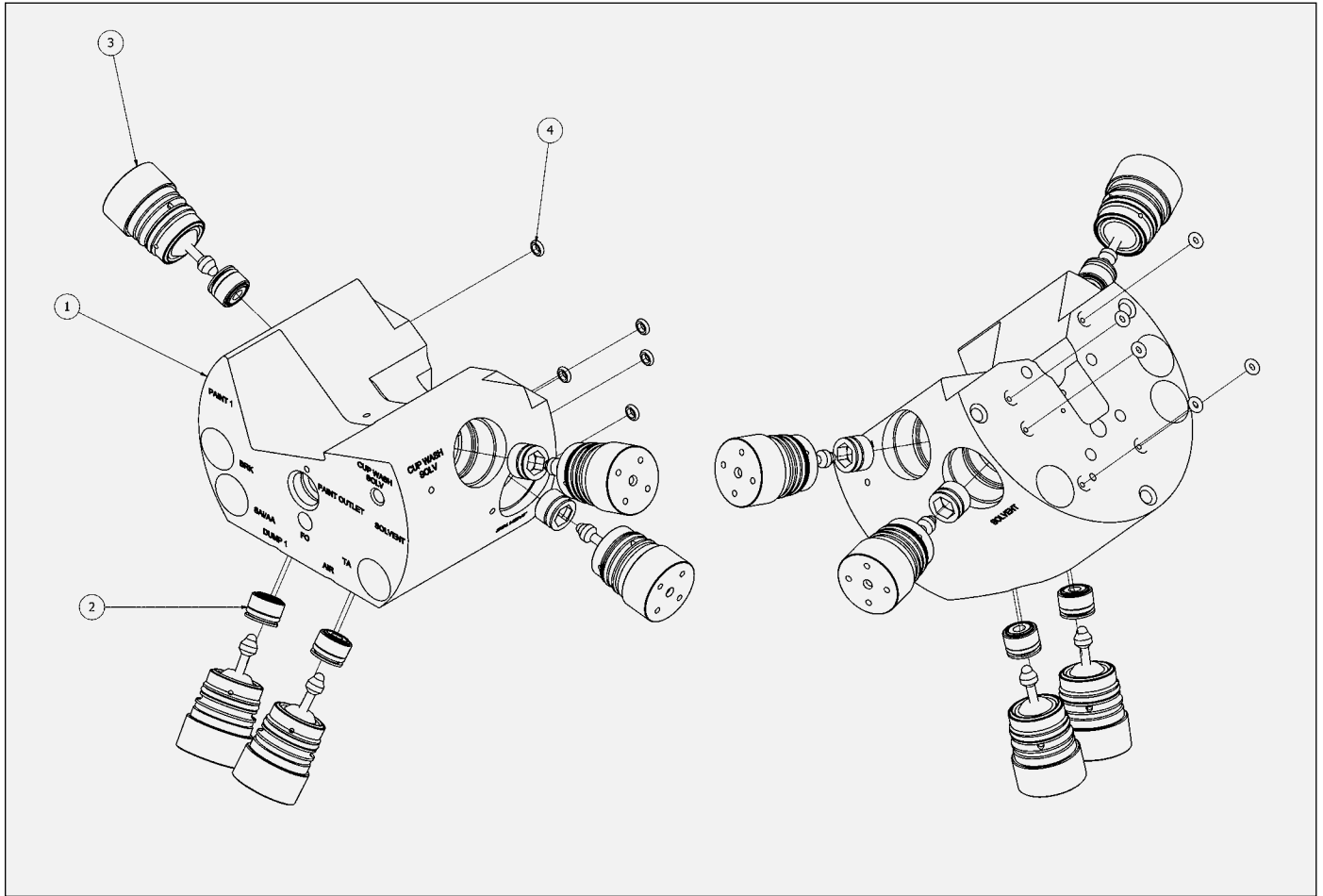

A13729-00 VALVE MANIFOLD ASSEMBLY - PARTS LIST

Item	Qty	Part #	Description
1	1	A13728-00	VALVE MANIFOLD (SINGLE PURGE)
2	5	77367-00	VALVE SEAT ASSEMBLY
3	5	78949-00	VALVE ASSEMBLY
4	5	79001-38	O-RING, SOLVENT PROOF



1. APPLY A LIGHT COATING OF A11545 PETROLATUM JELL TO ALL O-RINGS PRIOR TO ASSEMBLING

TORQUE TO 15-20 LBS/IN (1.69-2.26 Nm) AFTER VALVE IS DOWN

TORQUE TO 15-20 LBS/IN (1.69-2.26 Nm)

VALVE MANIFOLD ASSEMBLY (Dual Purge)

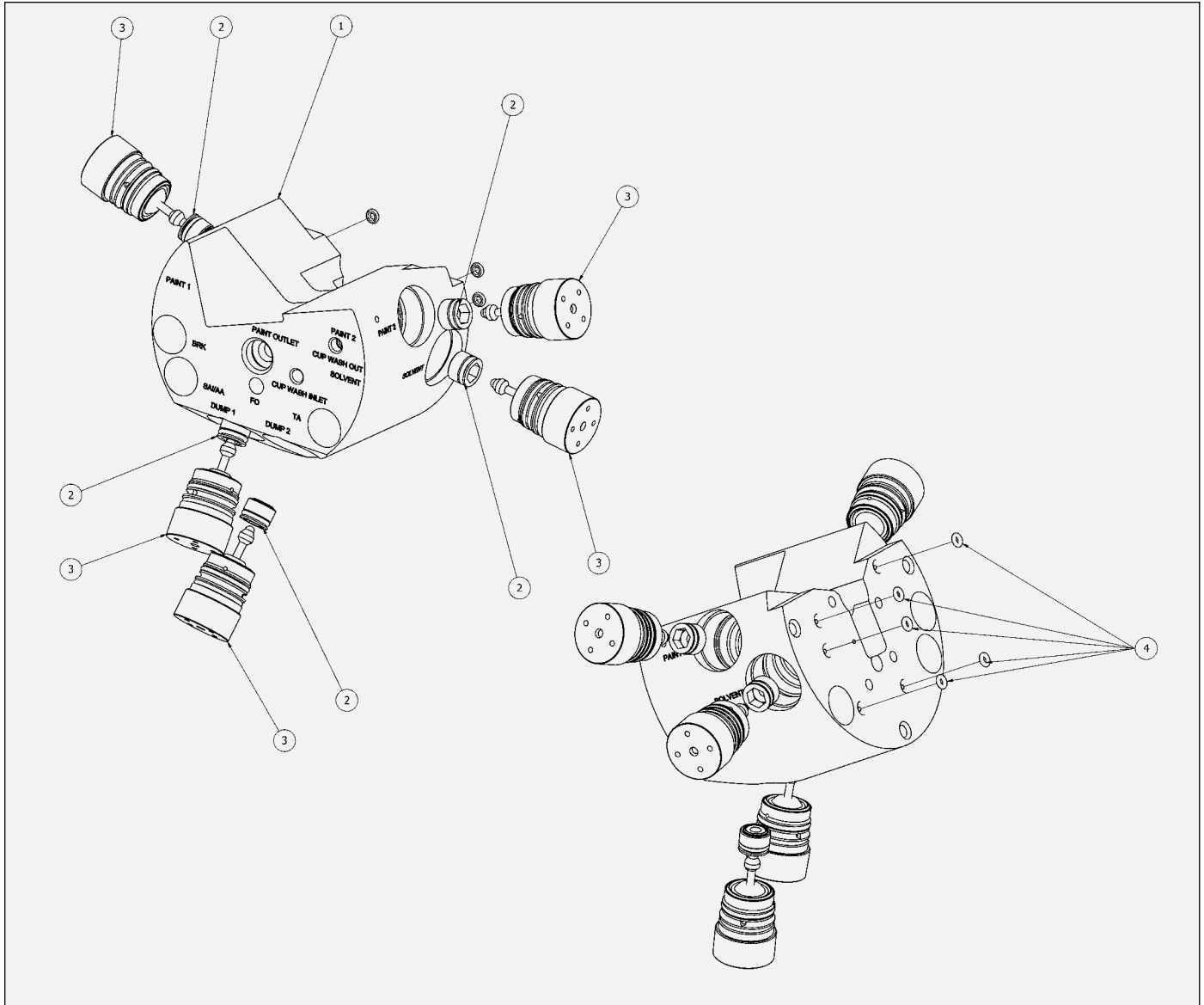

A13540-00 VALVE MANIFOLD ASSEMBLY - PARTS LIST

Item	Qty	Part #	Description
1	1	A13539-00	VALVE MANIFOLD
2	5	77367-00	VALVE SEAT ASSEMBLY
3	5	78949-00	VALVE ASSEMBLY
4	5	79001-38	O-RING, SOLVENT PROOF

1. APPLY A LIGHT COATING OF A11545 PETROLATUM JELL TO ALL O-RINGS PRIOR TO ASSEMBLING

- 3 TORQUE TO 15-20 LBS/IN (1.69-2.26 Nm) AFTER VALVE IS DOWN
- 2 TORQUE TO 15-20 LBS/IN (1.69-2.26 Nm)

SHAPING AIR KITS

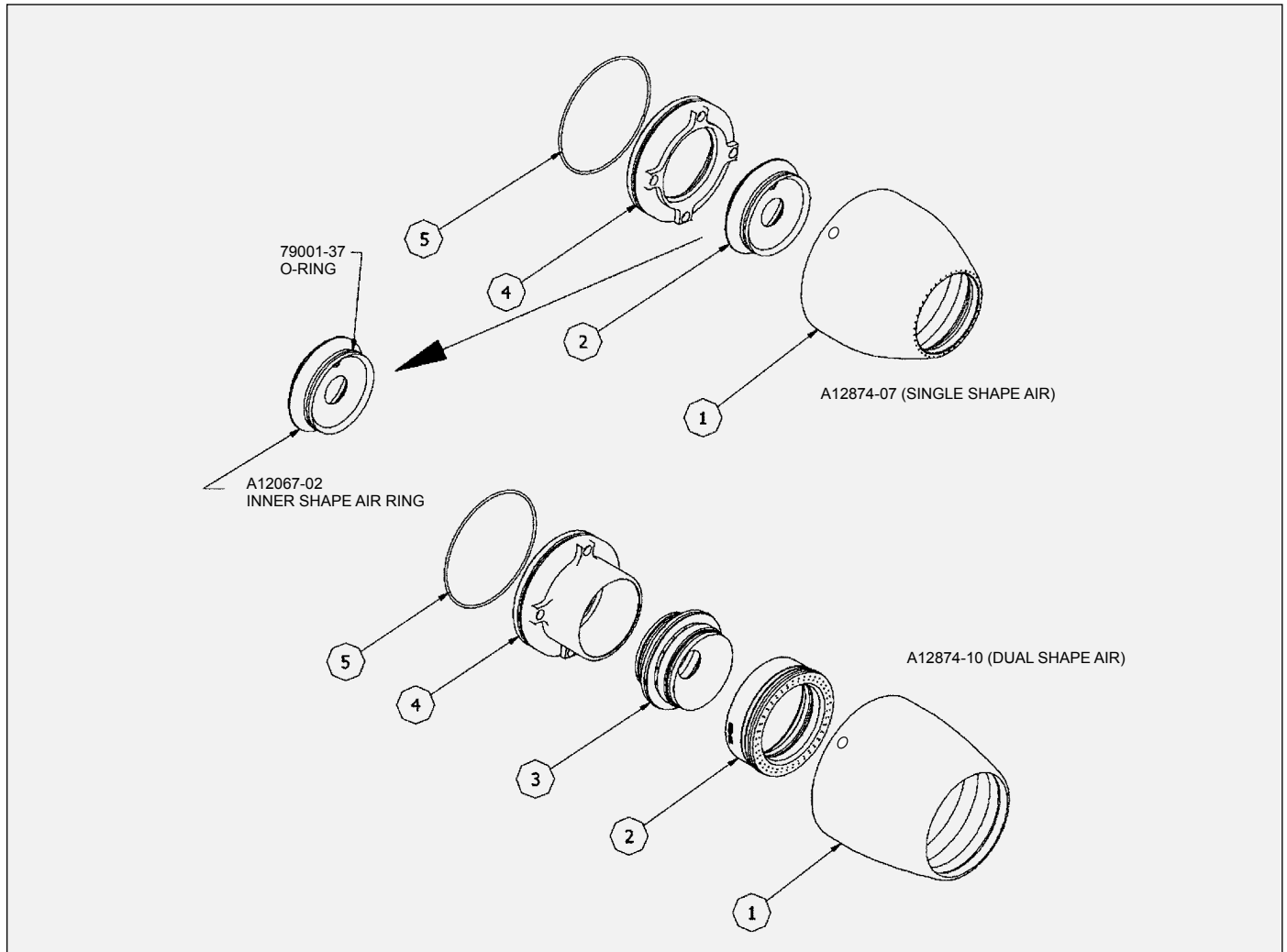

SHAPING AIR KIT - PARTS LIST

Item #	Part #	Description	Qty
1	A	Outer Shroud	1
2	B	Shaping Air Ring	1
3	C	Inner Shaping Air Ring	N
4	D	Turbine Retaining Ring	1
5	79001-11	O-Ring, Solvent Proof	1

SHAPING AIR KIT ASSEMBLY PARTS BREAK-DOWN

Part #	Description	A	B	C	D	E	N	P	R	S
A12874-07	SINGLE SHAPE AIR	A12068-03	A12083-02	-	A12078-02	-	-	-	-	-
A12874-10	DUAL SHAPE AIR	A12074-03	A12084-02	A12871-02	A12066-02	-	1	-	-	-

NOTE: Set screw for all shape air manifolds is A12253-00.

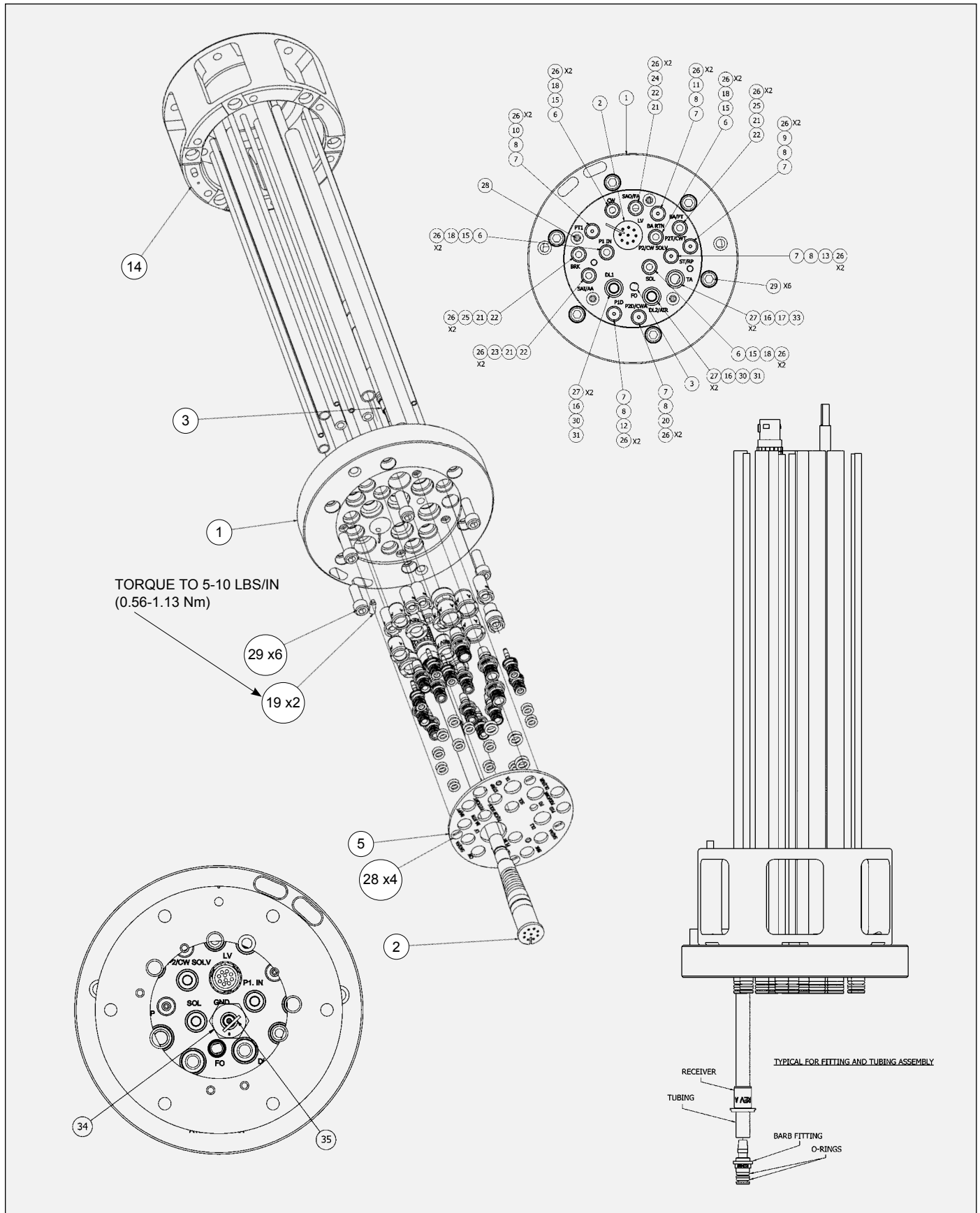

A13973-XXXXXXX Tubing Bundle Assembly

A13973-XXXXXXX TUBING BUNDLE ASSEMBLY MODEL IDENTIFICATION

When ordering, use A13973 A through G. Nine (9) digits must follow the basic part number. For example:

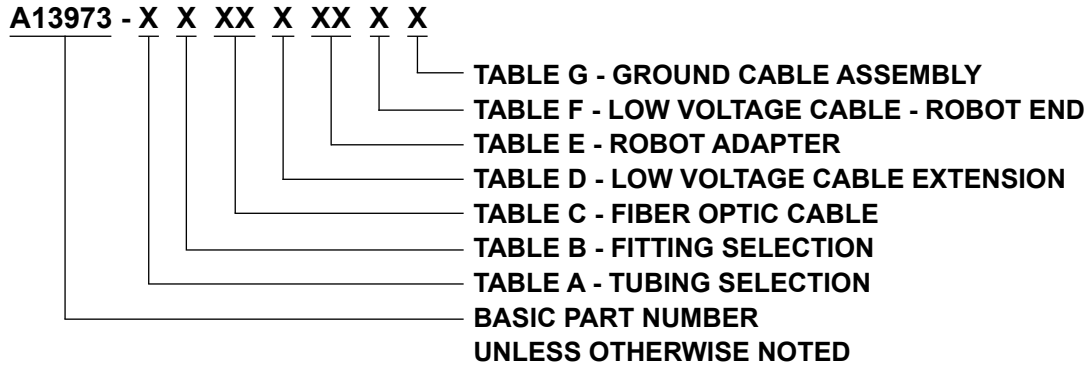

TUBING BUNDLE ASSEMBLY - PARTS LIST

Item	Qty	Part #	Description	Where Used
1	1	A13974-00	ROBOT PLATE ASSEMBLY (RMA SINGLE/DUAL PURGE)	
2	1	"F"	LOW VOLTAGE CABLE (QUICK DISCONNECT)	
3	1	"A"	FIBER OPTIC CABLE	
5	1	A13411-00	RETENTION PLATE	
6	"K"	A13410-00	BARB FITTING (8 X 5)	SOL, P1 IN, P2/CW SOLV, CW
7	"J"	A13407-00	FITTING (4MM X 2.7MM)	P2T/CWT, ST/RP, BA RTN, P1T, P1D, PTD/CWA
8	"H"	A13409-00	TUBE RECEIVER (4 X 2.7)	P2T/CWT, ST/RP, BA RTN, P1T, P1D, PTD/CWA
9	"G"	77536-05	TUBING, 4MM O.D.(NATURAL)	P2T/CWT
10	"T"	77536-03	TUBING, 4MM O.D.(GREEN)	P1T
11	"U"	77536-07	TUBING, 4MM O.D.(YELLOW)	BA RTN
12	"V"	77536-06	TUBING, 4MM O.D.(GREY)	P1D
13	"W"	77536-04	TUBING, 4MM O.D.(BLUE)	ST/RP
14	1	"B"	ROBOT ADAPTER	
15	"L"	A13405-00	RECEIVER (8 X 5)	SOL, P1 IN, P2/CW SOLV, CW
16	"M"	A13406-00	RECEIVER (10MM)	TA, DL1, DL2/AIR
17	"X"	A10839-06	TUBE, 10 MM OD X 8 MM ID (GREEN)	TA
18	"Y"	76698-02	TUBING, PFA	P2 / CW SOLV, CW, P1 IN, SOL
19	2	A13437-00	SET SCREW (M4 NYLON POINT)	
20	"O"	77536-01	TUBING (4MM BLACK)	P2D/CWA
21	"AC"	A13399-00	RECEIVER (8X6)	BA/PT, SAO/FA, BRK, SAI/AA,
22	"AD"	A13400-00	BARB FITTING (8X6)	BA/PT, SAO/FA, BRK, SAI/AA
23	"Z"	A10893-07	TUBING (8 X 6) BLUE	SAI
24	"AA"	A10893-04	TUBING (8 X 6) GRAY	SAO
25	"AB"	A10893-10	TUBING (8 X 6) NATURAL	BRK, BA/PT
26	"D"	79001-04	O-RING, SOLVENT PROOF	
27	"F"	79001-05	O-RING, SOLVENT PROOF	TA, DL1, DL2/AIR
28	4	A13438-00	SCREW, FLAT HEAD SLOTTED, M4 X 16MM, SS	RETENTION PLATE
29	6	76566-24C	SCREW, STAINLESS 1/4-20 X 3/4 LG. S.H.C.S.	ROBOT ADAPTER
30	"P"	A13538-00	BARB FITTING (10 X 7)	DL1, DL2/AIR
31	"Q"	A12211-00	TUBING (10MM X 7MM NYLON)	DL1, DL2/AIR
32	1	"C"	LOW VOLTAGE CABLE EXTENSION	
33	1	A13408-00	BARB FITTING (10 X 8)	TA
34	1	A10890-02	FITTING, 8MM ODT X 1/4 BSP	GND
35	1	"AE"	GROUND CABLE ASSEMBLY	

TABLE A - (TUBING SELECTION)

Dash #	Description	"G" Qty	"O" Qty	"Q" Qty	"T" Qty	"U" Qty	"V" Qty	"W" Qty	"X" Qty	"Y" Qty	"Z" Qty	"AA" Qty	"AB" Qty
0	No Tubing	None	None	None	None	None	None	None	None	None	None	None	None
1	Single/Dual Purge	42 ft.	42 ft.	42 ft.x2	42 ft.	42 ft.	42 ft.	42 ft.	6 ft.	42 ft.x4	42 ft.	42 ft.	42 ft.x2

TABLE B - (SINGLE/DUAL PURGE FITTING/RECEIVER SELECTION)

Dash #	Description	"D" Qty	"F" Qty	"H" Qty	"J" Qty	"K" Qty	"L" Qty	"M" Qty	"P" Qty	"AC"	"AD"
1	Single/Dual Purge	28	6	6	6	4	4	3	2	4	4

6

NOTE

- Turbine air (TA) to be supplied at a maximum length of 6 Ft. User or Integrator must increase to 12mm OD tube after 6 Ft.

TABLE C - FIBER OPTIC CABLE LENGTH

Dash #	Description	"C"
00	FIBER OPTIC CABLE (NOT INCLUDED)	N/A
01	3 FT. LONG, FIBER OPTIC CABLE	A12409-01
02	6 FT. LONG FIBER OPTIC CABLE	A12409-02
03	10 FT. LONG FIBER OPTIC CABLE	A12409-03
04	15 FT. LONG FIBER OPTIC CABLE	A12409-04
05	25 FT. LONG FIBER OPTIC CABLE	A12409-05
06	40 FT. LONG FIBER OPTIC CABLE	A12409-06
07	50 FT. LONG FIBER OPTIC CABLE	A12409-07
08	65 FT. LONG FIBER OPTIC CABLE	A12409-08
09	75 FT. LONG FIBER OPTIC CABLE	A12409-09
10	100 FT. LONG FIBER OPTIC CABLE	A12409-10
11	120 FT. LONG, FIBER OPTIC CABLE	A12409-21

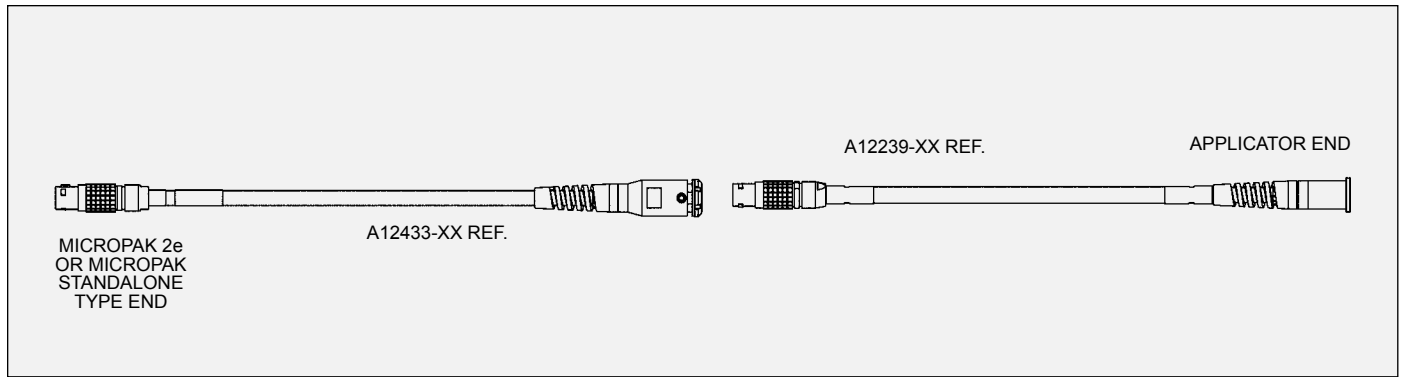

TABLE D - (LOW VOLTAGE CABLE EXTENSION)

Dash #	“C”	Description	Length
0	----	N/A	N/A
1	A12433-25	QUICK CONNECT TO MICROPAK 2e- QUICK CONNECT ENDS	25 FT.
2	A12433-50	QUICK CONNECT TO MICROPAK 2e- QUICK CONNECT ENDS	50 FT.
3	A12433-75	QUICK CONNECT TO MICROPAK 2e- QUICK CONNECT ENDS	75 FT.

TABLE E - ROBOT ADAPTER

Dash #	Description	“B”	Notes
00	ADAPTER NOT INCLUDED	N/A	
01	FANUC P145/P155	78983-00	STANDARD LENGTH WITH WINDOWS
02	ABB 5400, 5002	79107-00	STANDARD LENGTH WITH WINDOWS
03	FANUC P200/P250	79131-00	STANDARD LENGTH WITH WINDOWS
04	KAWASAKI KE610L	A10847-00	STANDARD LENGTH WITH WINDOWS
05	MOTOMAN PX2850	A10848-00	STANDARD LENGTH WITH WINDOWS
06	MOTOMAN PX2900	A10849-00	STANDARD LENGTH WITH WINDOWS
07	B&M LZ2000	A10851-00	STANDARD LENGTH WITH WINDOWS
08	ABB 5400 ENHANCED WRIST	A12036-00	STANDARD LENGTH WITH WINDOWS
09	MOTOMAN EPX2050	A13697-00	STANDARD LENGTH WITH WINDOWS
10	FANUC P200-P250	A13733-00	EXTENDED LENGTH WITH 1 WINDOW
11	KAWASAKI KE610L	A13734-00	EXTENDED LENGTH WITH 1 WINDOW
12	ABB 5400 ENHANCED WRIST	A13735-00	EXTENDED LENGTH WITH 1 WINDOW
13	MOTOMAN EXP2050	A13736-00	EXTENDED LENGTH WITH 1 WINDOW

TABLE F - LOW VOLTAGE CABLE - ROBOT END

Dash #	"F"	Description	Length
0	---	NONE	---
1	A12239-06	LOW VOLTAGE CABLE - QUICK CONNECT	6 FT.
2	A12239-10	LOW VOLTAGE CABLE - QUICK CONNECT	10 FT.
3	A12239-25	LOW VOLTAGE CABLE - QUICK CONNECT	25 FT.
4	A12239-50	LOW VOLTAGE CABLE - QUICK CONNECT	50 FT.
5	A12239-75	LOW VOLTAGE CABLE - QUICK CONNECT	75 FT.

TUBING BUNDLE NOMENCLATURE

SAO/FA	OUTER SHAPING AIR (OUTER AIR)
SAI/AA	INNER SHAPING AIR (INNER AIR)
BA/PT	BEARING AIR SUPPLY
BA, RTN	BEARING AIR RETURN
P1D	DUMP TRIGGER #1
DL2/AIR	DUMP OUT #2 / CUP WASH AIR
PT1	PAINT TRIGGER #1
P1 IN.	PAINT SUPPLY #1
ST/RP	SOLVENT TRIGGER
SOL	SOLVENT SUPPLY
TA	TURBINE AIR SUPPLY
LV	LOW VOLTAGE CABLE PORT
FO	FIBER OPTIC CABLE PORT
CW	CUP WASH (DUAL PURGE ONLY)
P2/CW SOLV	PAINT SUPPLY #2 (CUP WASH SOLVENT - SINGLE PURGE ONLY)
BRK	BRAKE AIR
P2T/CWT	PAINT TRIGGER #2 / CUP WASH SOLVENT TRIGGER
P2D/CWA	DUMP TRIGGER #2 / CUP WASH AIR TRIGGER
DL1	DUMP OUT #1

TABLE "G" - (GROUND CABLE)

Dash No.	Part Number	Description
0	A11680-10	CABLE, GROUND (10 FT.)
1	A11680-25	CABLE, GROUND (25 FT.)
2	A11680-50	CABLE, GROUND (50 FT.)
3	A11680-75	CABLE, GROUND (75 FT.)
4	A11680-100	CABLE, GROUND (100 FT.)

ATOMIZER RECOMMENDED SPARE PARTS

Part #	Description	Qty
A13906-00	Bell Cup Assembly	1-3
A13903-00	Insert (Bell Cup)	1-2
A12895-XX *	Air Turbine Assembly	0-1
A11717-00	Support Rod	1-2
A13826-00	Fluid Tube Assembly	0-1
75911-00	Fiber Optic Transmitter Assembly	1
A13542-00	Fiber Optic Cable Assembly	0-1
77367-00	Valve Seat Assembly	3-5
A11252-01	Tubing, FEP (Cup Wash)	50 ft. (20 Meters)
EMF-203-04	Front Ferrule, 1/4 O.D. Tubing, Fluid Coil	0-2
EMF-202-04	Back Ferrule, 1/4 O.D. Tubing, Fluid Coil	0-2
78278-00	Nut, Fiber Optic Transmitter	0-1
78949-00	Fitting, Fluid Coil	3-5
77516-04	Collet, 4mm	1
79001-30	O-ring, Solvent Proof	1
79001-07	O-ring, Solvent Proof	1
79001-14	O-ring, Solvent Proof	2
79001-38	O-ring, Solvent Proof	2
79001-09	O-ring, Solvent Proof	1
79001-39	O-ring, Solvent Proof	1
79001-40	O-ring, Solvent Proof	3
79001-41	O-ring, Solvent Proof	0-1
79001-42	O-ring, Solvent Proof	1
79001-44	O-ring, Solvent Proof	1
LSOR0005-18	O-ring, Encapsulated	1
79010-00	Cascade Assembly	1
7959-24C	Screw	4-6
A13437-00	Set Screw (F.O. and LV cables)	3
A11276-00	Fitting, Solvent (Cup Wash)	1-2
A11305-00	Lower Ferrule (Black- Cup Wash)	3-4
A11534-01	O-ring Kit (Turbine- Exterior)	1
A12253-00	Set Screw (Shape Air Manifolds)	1-2
A13328-00	Screw (Turbine Exhaust)	1-2
A13325-00	Diaphragm (Turbine Exhaust)	1-2
A12821-00	Cup Wash Ferrule (White)	3-4
A12822-00	Cup Wash Fitting	1-2
78949-00	Fluid Valve Assembly	3-5
A13953-00	Resistor Assembly	1
A13954-00	Resistor Cap	0-1

* Customer must verify spindle part number located on outer housing, see page 13.

ATOMIZER RECOMMENDED SPARE PARTS

Part #	Description	Qty
Select Option Below- Fluid Tip Size		
A13827-01	.7mm (.028")	0-1
A13827-02	.9mm (.035")	0-1
A13827-03	1.0mm (.039")	0-1
A13827-04	1.1mm (.043")	0-1
A13827-05	1.2mm (.047")	0-1
A13827-06	1.3mm (.051")	0-1
A13827-07	1.6mm (.062")	0-1
Select Option Below- Fluid Coil		
77531-00	1/4 O.D. x .170 I.D., PFA (3 Coils)	0-1
78450-00	1/4 O.D. X .125 I.D., PFA (11.5 Coils) Conductive Paints	0-1
77517-00	1/4 O.D. x .170 I.D., PFA (6.5 Coils)	0-1
Select Option Below- Shaping Air Kit A12874-10 (Dual Flex)		
A12074-03	Outer Shroud	0-1
A12084-02	Shaping Air Ring	0-1
A12871-02	Inner Shaping Air ring	0-1
A12066-02	Turbine Retaining Ring	0-1
79001-11	O-ring, Solvent Proof	1
79001-37	O-ring, Solvent Proof	1-2
79001-54	O-ring, Solvent Proof	1
A12253-00	Set Screw	1-2
Select Option Below- Shaping Air Kit A12874-07 (Mono Flex)		
A12068-03	Outer Shroud	0-1
A12083-02	Shaping Air Ring	0-1
A12078-02	Turbine Retaining Ring	0-1
79001-11	O-ring, Solvent Proof	1
79001-37	O-ring, Solvent Proof	1-2
A12253-00	Set Screw	1-2
Select Option Below- Mounting Ring		
A13455-04	Mounting Ring Plastic W/Skirt Extension	0-1
A11201-03	Mounting Ring Stainless Steel	0-1
Select Option Below- Mounting Ring		
A13444-00	Shroud, Round W/Logo	0-1
A13559-00	Split Shroud Assembly	0-1

TUBING BUNDLE RECOMMENDED SPARE PARTS

Part #	Description	Qty
Select Option Below- A13973 Tubing Bundle Assembly		
A13411-00	Retention Plate	1
A13438-00	Screw (For Retention Plate)	3-5
A13437-00	Set Screw (For Low Voltage Cable and Fiber Optic)	1-2
79001-04	O-ring, Solvent Proof	10-15
79001-05	O-ring, Solvent Proof	2-4
A13410-00	Barb Fitting (8x5)	1-2
A13405-00	Receiver (8x5)	1-2
A13400-00	Barb Fitting (8x6)	1-2
A13399-00	Receiver (8x6)	1-2
A13408-00	Barb Fitting (10x8)	1-2
A13406-00	Receiver (10x8) (10x7)	1-2
A13538-00	Barb Fitting (10x7)	1-2
A13407-00	Barb Fitting (4mm)	1-2
A13409-00	Receiver (4mm)	1-2
Select Option Below- Low Voltage Cable Extension		
A12433-50	Quick Connect to MicroPak 2e - Quick Connect Ends 50 Ft. (15.2 Meters)	1
A12433-75	Quick Connect to MicroPak 2e - Quick Connect Ends 75 Ft. (22.9 Meters)	1
Select Option Below- Fiber Optic Cable		
A12409-01	3 Ft. (0.9 Meters) (Metal Ferrule)	1
A12409-02	6 Ft. (1.8 Meters) (Metal Ferrule)	1
A12409-03	10 Ft. (3 Meters)	1
A12409-04	15 Ft. (4.6 Meters)	1
A12409-05	25 Ft. (7.6 Meters)	1
A12409-06	40 Ft. (12.2 meters)	1
A12409-07	50 Ft. (15.2 Meters)	1
A12409-08	65 Ft. (18.3 Meters)	1
A12409-09	75 Ft. (22.9 Meters)	1
A12409-10	100 Ft. (30.5 Meters)	1
A12409-21	120 Ft. (36.5 Meters)	1
Select Option Below- Fiber Optic Cable - A12239-XX		
A12239-06	Low Voltage Cable - Robot Plate to Bulkhead 6 Ft. (1.8 Meters)	1
A12239-10	Low Voltage Cable - Robot Plate to Bulkhead 10 Ft. (3 Meters)	1
A12239-25	Low Voltage Cable - Robot Plate to Bulkhead 25 Ft. (7.6 Meters)	1
A12239-50	Low Voltage Cable - Robot Plate to Bulkhead 50 Ft. (15.2 Meters)	1
A12239-75	Low Voltage Cable - Robot Plate to Bulkhead 75 Ft. (22.9 Meters)	1

TUBING BUNDLE RECOMMENDED SPARE PARTS (Cont.)

Part #	Description	Qty
Select Option Below- Tubing		
77536-01	Tubing 4mm Nylon (Black)	---
77536-03	Tubing 4mm Nylon (Green)	---
77536-04	Tubing 4mm Nylon (Blue)	---
77536-05	Tubing 4mm Nylon (Natural)	---
77536-06	Tubing 4mm Nylon (Grey)	---
77536-07	Tubing 4mm Nylon (Yellow)	---
76698-02	Tubing, PFA (5/16" x 3/16")	---
A10893-04	Tubing 8 x 6 Nylon (Gray)	---
A10893-07	Tubing 8 x 6 Nylon (Blue)	---
A10893-10	Tubing 8 x 6 Nylon (Natural)	---
A12221-00	Tubing 10 x 7 Nylon (Natural)	---
Select Option Below- Ground Cable Assembly		
A11680-10	Cable, Ground 10 Ft. (3 Meters)	1
A11680-25	Cable, Ground 25 Ft. (7.6 Meters)	1
A11680-50	Cable, Ground 50 Ft. (15.2 Meters)	1
A11680-75	Cable, Ground 75 Ft. (22.9 Meters)	1
A11680-100	Cable, Ground 100 Ft. (30.5 Meters)	1

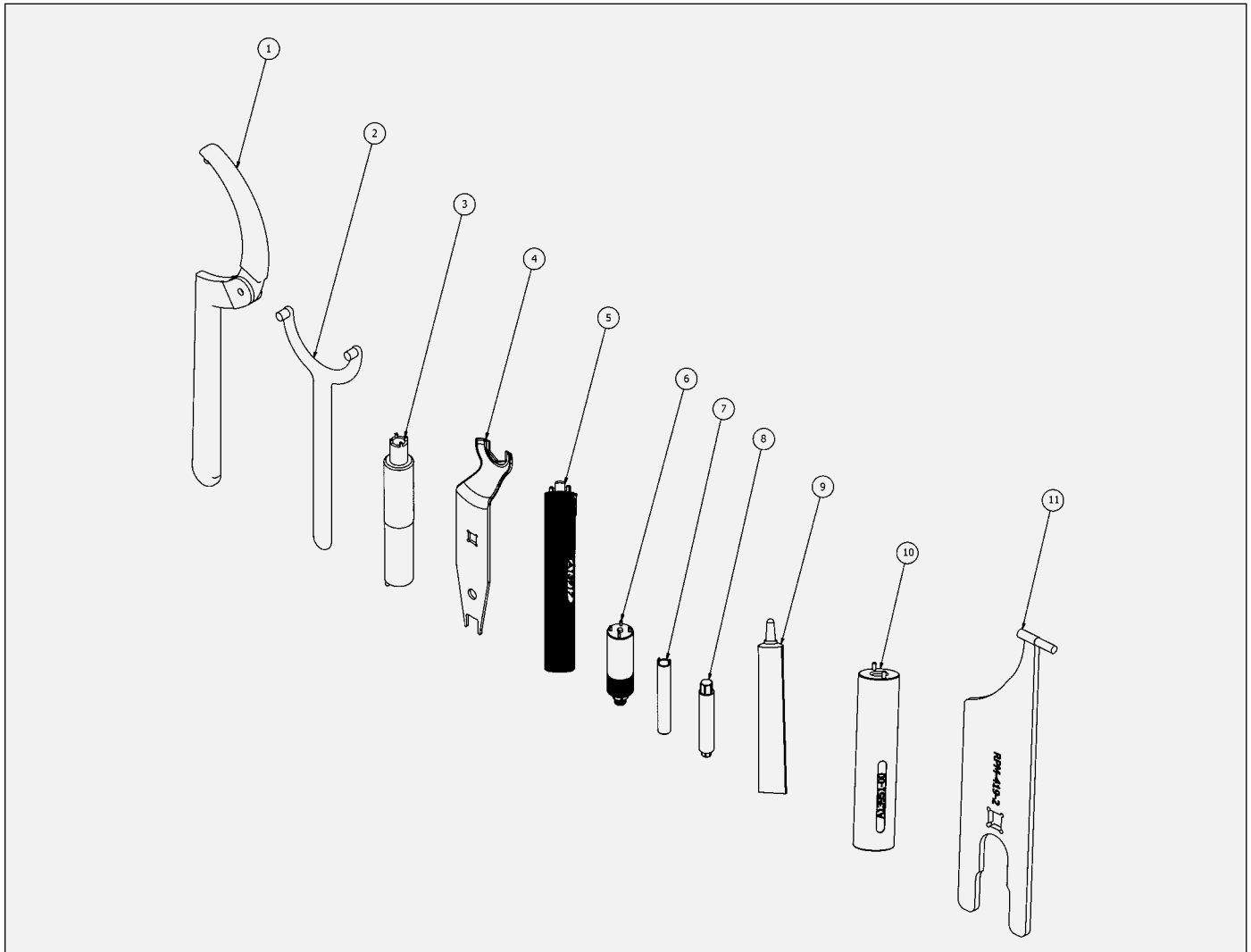

Assembly Tools

ASSEMBLY TOOLS - (A13926-00 TOOL KIT)

Item #	Part #	Description
1	76772-01	WRENCH, SPANNER
2	A12088-00	WRENCH, TURBINE RETAINING RING
3	A11229-00	TOOL, FLUID TIP/TUBE REMOVAL
4	A12061-00	WRENCH, BELL CUP
5	A13917-00	BELL CUP INSERT REMOVAL
6	A11922-00	TOOL, VALVE REMOVAL
7	78279-00	TOOL, FIBER OPTIC
8	A10766-00	MICROVALVE SEAT REMOVAL
9	LSCH0009-00	DIELECTRIC GREASE, 0.88 OZ.
10	A13951-00	TOOL, RESISTOR CAP
11	RPM-419-2	WRENCH

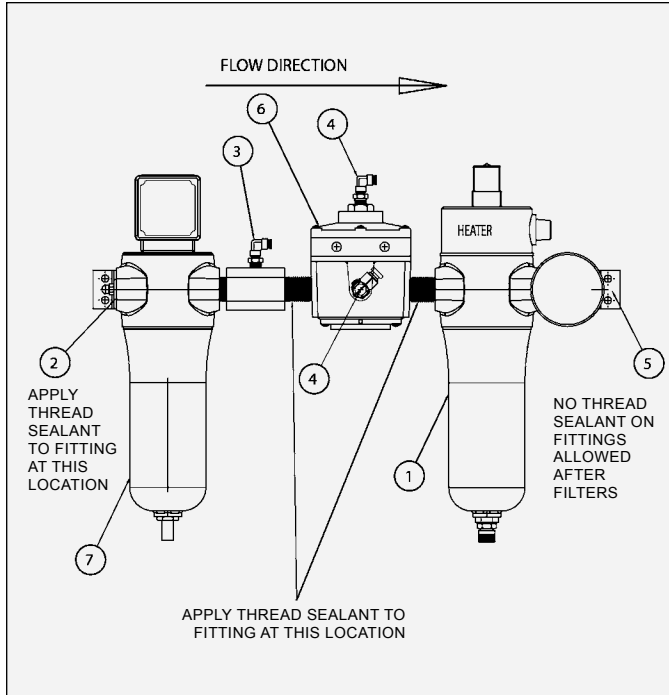

A13230-XX Air Heater and Filter Combination

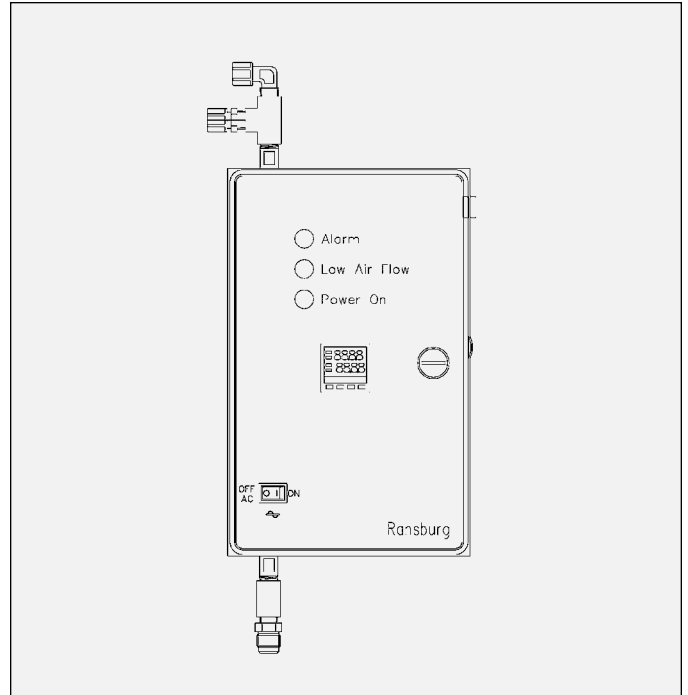

A11065-05 Air Heater

FILTER & HEATER ASSEMBLY A13230-XX

Dash No.	Description	"A"	"B"	"C"	"D"	"E"
A13230-01	115 V.@ 13A METRIC FITTINGS	A13434-01	A13426-00	A13429-00	A13433-00	A13726-00
A13230-02	230 V.@ 6.5A METRIC FITTINGS	A13434-02	A13426-00	A13429-00	A13433-00	A13726-00
A13230-03	115 V.@ 13A FRACTIONAL FITTINGS	A13434-01	SSP-6439	A13428-00	A13433-00	A13727-00
A13230-04	230 V.@ 6.5A FRACTIONAL FITTINGS	A13434-02	SSP-6439	A13428-00	A13433-00	A13727-00

A13230-XX AIR HEATER AND FILTER COMBINATION

Item	Part #	Description	Qty.
1	"A"	AIR BLOCK, NIPPLES & AIR HEATER	1
2	A13427-00	INLET FITTING, 3/8 NPS(M) X 1/2 NPT(M)	1
3	"B"	BEARING AIR FEED, SWIVEL ELBOW 1/4 O.D.TUBE X 1/4 NPT(M)	1
		BEARING AIR FEED, 6mm O.D. TUBE X 1/4 NPT(M) STRAIGHT ADAPTER	
4	79253-02	AIR FITTING, SWIVEL ELBOW 5/32 O.D. TUBE X 1/4 NPT(M)	2
5	"C"	OUTLET FITTING, 1/2 O.D. TUBE X 1/2 NPT(M) STAINLESS STEEL	1
		OUTLET FITTING, 12mm O.D. TUBE X 1/2 NPT(M) STAINLESS STEEL	
6	A11111-00	VOLUME BOOSTER	1
7	"D"	AIR FILTER & NIPPLE INCLUDED	1
8	LN-9811-14	A13230-XX SERVICE MANUAL	1

ALL UNITS: REPLACEMENT PARTS: (SERVICE NOTE)
 HEATING ELEMENT USE: A13432-01 FOR A13230-01 AND A13230-03 (115V UNITS)
 A13432-02 FOR A13230-02 AND A13230-04 (230V UNITS)
 AIR FILTER ELEMENT USE A13232-00
 THERMOMETER USE A13431-00

SERVICE KITS

Part #	Description
HAF-15	Pre-Filter Replacement Element
HAF-38	Pre-Filter Replacement Element
RPM-33	Bearing Air Filter Element
A11065-05	Air Heater
A12247-00	Bell Cup Removal Tool
A11570-01	Reducing Straight Connector, Push To Connect, 6mm OD Tube To 4mm OD Tube
A11570-02	Reducing Straight Connector, Push To Connect, 8mm OD Tube To 4mm OD Tube
A11570-03	Reducing Straight Connector, Push To Connect, 8mm OD Tube To 6mm OD Tube
A11570-04	Reducing Straight Connector, Push To Connect, 10mm OD Tube To 4mm OD Tube
A11570-05	Reducing Straight Connector, Push To Connect, 10mm OD To 6mm OD Tube
A11570-06	Reducing Straight Connector, Push To Connect, 10mm OD To 8mm OD Tube
A11570-07	Reducing Straight Connector, Push To Connect, 12mm OD To 8mm OD Tube
A11570-08	Reducing Straight Connector, Push To Connect, 12mm OD To 10mm OD Tube

LUBRICANTS AND SEALERS

Part #	Description
A11545-00	Petrolatum Jell Lubricant for all O-Rings

AIR FILTER / REPLACEMENT

Ransburg Part #	Qty. Elements Per Carton	Used On
HAF-15	1	HAF-503
HAF-38	4	HAF-508
RPM-33	8	RPM-418

ACCESSORIES

Part #	Description
LSCH0009-00	Dielectric Grease (.8 oz. Tube)
76652-01	Kit for measuring high voltage. (Includes Multi-Function Meter (76634-00) and High Voltage Probe Assembly (76667-00).
76652-02	Kit for measuring short circuit current (SCI), resistance, and spray ability. Includes Multi-Function Meter (76634-00) and Test Lead Assembly (76664-00).
76652-03	Kit for measuring resistivity. (Includes Multi-Function Meter (76634-00) and Paint Probe Assembly (7922-00).
76652-04	Deluxe Kit (Performs all functions listed above.) Includes Multi-Function Meter (76634-00), Paint Probe Assembly (7922-00), Test Lead Assembly (76664-00), and High Voltage Probe Assembly. (76667-00).
A11567-00	Groove Tool, 1/4" OD Tube

MANUAL CHANGE SUMMARY

LN-9284-15-R5 - Replaces LN-9284-15.4 with the following changes:

No.	Change Description	Page(s)
1.	Remove "CE" logos and bring format up to date	All

WARRANTY POLICY

This product is covered by Carlisle Fluid Technologies materials and workmanship limited warranty. The use of any parts or accessories, from a source other than Carlisle Fluid Technologies, will void all warranties. For specific warranty information please contact Carlisle Fluid Technologies.

Carlisle Fluid Technologies is a global leader in innovative finishing technologies. Carlisle Fluid Technologies reserves the right to modify equipment specifications without prior notice.

DeVilbiss®, Ransburg®, MS®, BGK®, and Binks®,
are registered trademarks of Carlisle Fluid Technologies, Inc.

©2020 Carlisle Fluid Technologies, Inc.
All rights reserved.

For technical assistance or to locate an authorized distributor, contact one of our international sales and customer support locations.

Region	Industrial / Automotive	Automotive Refinishing
Americas	Tel: 1-800-992-4657 Fax: 1-888-246-5732	Tel: 1-800-445-3988 Fax: 1-800-445-6643
Europe, Africa Middle East, India	Tel: +44 (0)1202 571 111 Fax: +44 (0)1202 573 488	
China	Tel: +8621-3373 0108 Fax: +8621-3373 0308	
Japan	Tel: +81 45 785 6421 Fax: +81 45 785 6517	
Australia	Tel: +61 (0) 2 8525 7555 Fax: +61 (0) 2 8525 7575	

For the latest information about our products, visit www.carlisleft.com.