

## MX22060 & MX19070 Pump & Packages

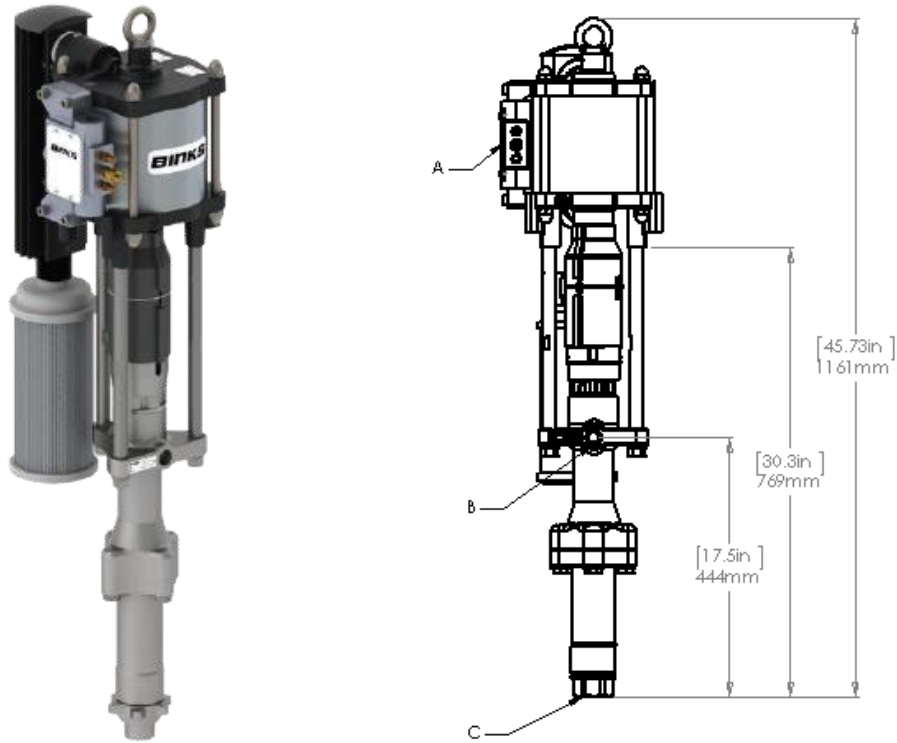

Models: MX22060##-XXX & MX19070##-XXX , ## = PP (PTFE), PU (PTFE/UHMW), PL (PTFE/LEATHER), UL (UHMW/LEATHER), UU (UHMW/UHMW)



Patent 7,603,855.

SPECIFICATION - Bare Pump		
	MX22060	MX19070
Ratio:	60:1	70:1
Maximum air inlet pressure:	8 bar [116 psi]	7 bar [101.5 psi]
Maximum fluid pressure:	480 bar [4176 psi]	490 bar [4263 psi]
Displacement per cycle:	220 ml [7.4 oz]	190 ml [6.4 oz]
Output @ 60 cycles/min:	13.2 l/m [3.5 US gal/m]	11.4 l/m [3.0 US gal/m]
Air consumption @ 20 cycles/min and 7 bar [101.5 psi] air inlet pressure:	1982 l/m [70 SCFM]	
Maximum recommended continuous cycle rate (cycles/min):	20	
A	Air inlet connection:	3/4" BSPP (f)
C	Fluid inlet connection:	1 1/4" NPT (f)
B	Fluid outlet connection:	3/4" NPT (f)
	Sound level @ 7 Bar:	79.5 Dba Leq
	Weight:	53.5 kg [118 lbs]
	Wetted parts materials of construction:	See fluid section

**Product Description / Object of Declaration:** MX4\*\*, MXL4\*\*, MX12\*\*, MXL12\*\*, MX122\*\*,  
MX190\*\*, MX220\*\*, MMX4\*\*, MMX12\*\*

**EN**

**This Product is designed for use with:** Solvent and Water based Materials

**Suitable for use in hazardous area:** Zone 1

**Protection Level:** II 2 G c X IIB T4

**Notified body details and role:** Element Materials Technology (0891)  
Lodging of Technical file

**This Declaration of conformity /  
incorporation is issued under the sole  
responsibility of the manufacturer:** Carlisle Fluid Technologies UK Ltd,  
Ringwood Road,  
Bournemouth, BH11 9LH. UK

## EU Declaration of Conformity



**The object of the declaration described above is in conformity with the relevant Union harmonisation legislation:**

Machinery Directive 2006/42/EC

ATEX Directive 2014/34/EU

by complying with the following statutory documents and harmonized standards:

EN ISO 12100:2010 Safety of Machinery - General Principles for Design

EN 12621:+A1:2010 Machinery for the supply and circulation of coating materials under pressure - Safety requirements

EN1127-1:2011 Explosive atmospheres - Explosion prevention - Basic concepts

EN 13463-1:2009 Non electrical equipment for use in potentially explosive atmospheres - Basic methods and requirements



EN 13463-5:2011 Non electrical equipment for use in potentially explosive atmospheres - Protection by constructional safety

Providing all conditions of safe use / installation stated within the product manuals have been complied with and also installed in accordance with any applicable local codes of practice.

Signed for and on behalf of Carlisle Fluid  
Technologies UK Ltd:

D Smith  
30/3/17

Director of Sales (EMEA)  
Bournemouth, BH11 9LH, UK

 <b>WARNING</b>	 <b>CAUTION</b>	<b>NOTE</b>
Hazards or unsafe practices which could result in severe personal injury, death or substantial property damage.	Hazards or unsafe practices which could result in minor personal injury, product or property damage	Important installation, operation or maintenance information.

 **WARNING**

Read the following warnings before using this equipment.

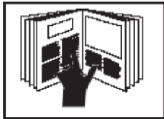

**READ THE MANUAL.** Before operating finishing equipment, read and understand all safety, operation and maintenance information provided in the operation manual.



**AUTOMATIC EQUIPMENT.** Automatic equipment may start suddenly without warning.



**WEAR SAFETY GLASSES.** Failure to wear safety glasses with side shields could result in serious eye injury or blindness.

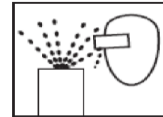

**PROJECTILE HAZARD.** You may be injured by venting liquids or gases that are released under pressure, or flying debris.



**DE-ENERGIZE, DE-PRESSURISE, DISCONNECT AND LOCK OUT ALL POWER SOURCES DURING MAINTENANCE.** Failure to de-energize, disconnect and lock out all power supplies before performing equipment maintenance could cause serious injury or death.



**KNOW WHERE AND HOW TO SHUT OFF THE EQUIPMENT IN CASE OF AN EMERGENCY.**



**NOISE LEVELS.** The A-weighted sound level of pumping and spray equipment may exceed 85 dB(A) depending on equipment settings. Actual noise levels are available on request. It is recommended that ear protection is worn at all times while equipment is in use.



**PRESSURE RELIEF PROCEDURE.** Always follow the pressure relief procedure in the equipment instruction manual.



**INSPECT THE EQUIPMENT DAILY.** Inspect the equipment for worn or broken parts on a daily basis. Do not operate the equipment if you are uncertain about its condition.

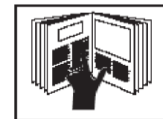

**OPERATOR TRAINING.** All personnel must be trained before operating finishing equipment.



**EQUIPMENT MISUSE HAZARD.** Equipment misuse can cause the equipment to rupture, malfunction or start unexpectedly and result in serious injury.



**PACEMAKER WARNING.** You are in the presence of magnetic fields which may interfere with the operation of certain pacemakers.



**HIGH PRESSURE CONSIDERATION.** High pressure can cause serious injury. Relieve all pressure before servicing. Spray from the gun, hose leaks or ruptured components can inject fluid into your body and cause extremely serious injury.



**KEEP EQUIPMENT GUARDS IN PLACE.** Do not operate the equipment if the safety devices have been removed.



**STATIC CHARGE.** Fluid may develop a static charge that must be dissipated through proper grounding of the equipment, objects to be sprayed and all other electrically conductive objects in the dispensing area. Improper grounding or sparks can cause a hazardous condition and result in fire, explosion or electric shock and other serious injury.



**NEVER MODIFY THE EQUIPMENT.** Do not modify the equipment unless the manufacturer provides written approval.



**PROP 65 WARNING.** WARNING: This product contains chemicals known to the state of California to cause cancer and birth defects or other reproductive harm.



**PINCH POINT HAZARD.** Moving parts can crush and cut. Pinch points are any areas where there are moving parts.

**IT IS THE RESPONSIBILITY OF THE EMPLOYER TO PROVIDE THIS INFORMATION TO THE OPERATOR OF THE EQUIPMENT.**

## PUMP OPERATION AND CLEANING

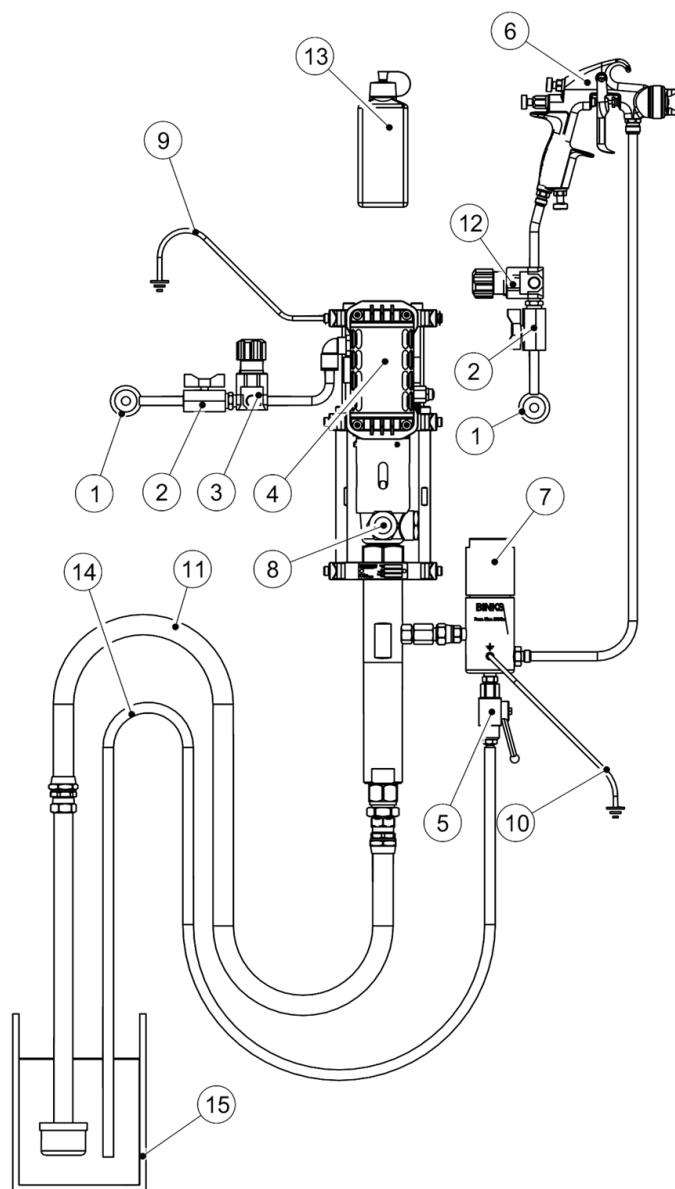

1	AIR SUPPLY
2	AIR SHUT OFF VALVE (IF FITTED)
3	AIR PRESSURE REGULATOR
4	BINKS PUMP
5	FLUID PRESSURE RELIEF VALVE (IF FITTED)
6	SPRAY GUN
7	FLUID FILTER (IF FITTED)
8	LUBRICATION CUP & LEVEL
9	EARTH CABLE AIR MOTOR
10	EARTH CABLE FLUID FILTER (IF FITTED)
11	FLUID SUCTION HOSE/SUCTION TUBE/GRAVITY HOPPER - DEPENDING ON MODEL
12	AIR PRESSURE REGULATOR (SPRAY GUN) (IF FITTED)
13	LUBRICANT 0114-016099 SOLVENT BASED MATERIALS 0114-016100 WATER BASED MATERIALS
14	RELIEF/RETURN HOSE (IF FITTED)
15	FLUID CONTAINER

**WARNING**

WEAR EYE PROTECTION WHEN OPERATING THIS EQUIPMENT

**WARNING**

PUMP MUST BE GROUNDED BEFORE OPERATING, TO PREVENT STATIC CHARGES.

**WARNING**

HOSES MUST HAVE A SUITABLE WORKING PRESSURE ABOVE THE MAXIMUM PRESSURE POSSIBLE.

## INSTALLATION

- 1 - ENSURE THE PUMP IS LOCATED ON A SUITABLE & STABLE MOUNTING.
- 2 - GROUND/EARTH THE PUMP WITH (9) OR (10), CHECK EARTH IS LESS THAN 1 Ohm.
- 3 - CONNECT SUITABLE HOSES FOR AIR SUPPLY AND FLUID HOSE TO GUN.
- 4 - FILL THE LUBRICATION CUP (8) WITH A SUITABLE LUBRICANT (13) SO IT IS VISIBLE IN THE LEVEL SIGHT GLASS.
- 5 - ENSURE SUITABLE FILTER MESH (100 MESH, 150 µm STD) IS INSTALLED IN THE FILTER(7).
- 6 - ENSURE RETURN HOSE (14) IF FITTED, IS DIRECTED INTO THE FLUID CONTAINER (15).

## CLEANING THE PUMP

<b>NOTE</b>	THE PUMP HAS BEEN TESTED WITH OIL, WATER OR OTHER MATERIAL. CLEAN THE PUMP PRIOR TO USE TO AVOID ANY CONTAMINATION.
-------------	---

- 1 - INSERT SUCTION SYSTEM (11) & RETURN HOSE (14) (IF FITTED) INTO A CONTAINER WITH SUITABLE CLEANING FLUID.
- 2 - CLOSE VALVE (2) AND SET REGULATORS (3) & (12) TO ZERO ( WIND ANTICLOCKWISE), OPEN VALVE (5) IF FITTED.
- 3 - REMOVE FLUID NOZZLE FROM THE SPRAY GUN FOR RETURNING FLUID INTO THE CONTAINER
- 4 - CONNECT AIR SUPPLY
  - a) IF (5) IS FITTED:
    - 5a - OPEN VALVE (2), INCREASE REGULATOR PRESSURE (3) UNTIL PUMP STARTS TO OPERATE (APPROX. 1 BAR [14.5 PSI])
    - 6a - ALLOW FLUID TO CIRCULATE FOR SEVERAL MINUTES OR UNTIL SYSTEM IS CLEAN.
    - 7a - CLOSE VALVE (5) AND TRIGGER SPRAY GUN INTO CONTAINER FOR SEVERAL MINUTES TO CLEAN HOSE & GUN.
    - 8a - WITH THE TRIGGER STILL OPEN REDUCE REGULATOR PRESSURE (3) TO ZERO, AND OPEN VALVE (5) IF FITTED AND CLOSE TRIGGER.
  - b) IF (5) IS NOT FITTED.
    - 5b - TRIGGER SPRAY GUN AND HOLD OVER CONTAINER, INCREASE REGULATOR PRESSURE (3) UNTIL PUMP STARTS TO OPERATE (APPROX. 1 BAR [14.5PSI])
    - 6b - ALLOW FLUID TO CIRCULATE FOR SEVERAL MINUTES OR UNTIL SYSTEM IS CLEAN.
    - 7b - WITH THE TRIGGER STILL OPEN REDUCE REGULATOR PRESSURE(3) TO ZERO AND ENSURE NO PRESSURE IS LEFT IN THE HOSE AND GUN BEFORE CLOSING THE TRIGGER.

<b>NOTE</b>	REPEAT CLEANING PROCESS UNTIL CLEANING FLUID HAS NO CONTAMINATION, ESPECIALLY IF THE PUMP WILL NOT BE USED IMMEDIATELY, OR HAS BEEN USED WITH 2 COMPONENT PAINTS.
 <b>CAUTION</b>	WHEN THE SPRAY GUN IS NOT IN USE THE SAFTEY LOCK SHOULD BE ENGAGED TO PREVENT ACCIDENTAL OPERATION.

## STARTUP

- 1 - INSERT SUCTION SYSTEM (11) & RETURN HOSE (14) (IF FITTED) INTO A CONTAINER WITH THE FLUID TO BE SPRAYED
- 2 - CLOSE VALVE (2) AND SET REGULATORS (3) AND (12) TO ZERO (WIND ANTICLOCKWISE), OPEN VALVE (5) IF FITTED.
- 3 - REMOVE SPRAY TIP FROM THE GUN FOR RETURNING FLUID INTO THE CONTAINER.
- 4 - CONNECT AIR SUPPLY.
- a) IF (5) IS FITTED
  - 5a - OPEN VALVE (2), INCREASE REGULATOR PRESSURE (3) UNTIL PUMP STARTS TO OPERATE.
  - 6a - WHEN FLUID FLOWS THROUGH HOSE (14) WITHOUT AERATION, CLOSE VALVE (5).
  - 7a - OPEN SPRAY GUN TRIGGER UNTIL FLUID FLOWS INTO CONTAINER WITHOUT AIR, THEN RELEASE TRIGGER.
- b) IF (5) IS NOT FITTED.
  - 5b - TRIGGER THE SPRAY GUN AND HOLD OVER CONTAINER, INCREASE REGULATOR PRESSURE (3) UNTIL PUMP STARTS TO OPERATE.
  - 6b - KEEP TRIGGER OPEN UNTIL FLUID FLOWS INTO CONTAINER WITHOUT AERATION, THEN RELEASE TRIGGER.
- 8 - REDUCE REGULATOR PRESSURE (3) TO ZERO.
- 9 - APPLY SPRAY GUN SAFETY LOCK WHILE SPRAY TIP IS FITTED.
- 10 - INCREASE REGULATOR PRESSURE(3) UNTIL DESIRED ATOMISATION IS ACHIEVED FROM SPRAY GUN.
- 11 - INCREASE REGULATOR PRESSURE (12) TO ACHIEVE DESIRED SPRAY FAN.

## SHUT DOWN

- 1 - REDUCE REGULATOR PRESSURE (3) AND (12) TO ZERO.
- 2 - TRIGGER GUN TO REDUCE SYSTEM PRESSURE.
- 3 - OPEN VALVE (5) SLOWLY IF FITTED.
- 4 - APPLY SPRAY GUN SAFETY LOCK WHILE SPRAY TIP IS REMOVED
- 5 - TRIGGER GUN CAREFULLY INTO CONTAINER AND ENSURE FLUID SYSTEM IS DE-PRESSURISED.
- 6 - CLOSE VALVE(2) AND REMOVE AIR SUPPLY.
- 7 - APPLY SPRAY GUN SAFETY LOCK.
- 8 - CLEAN AS INSTRUCTED AND SOAK/CLEAN SPRAYGUN FLUID NOZZLE.

<b>NOTE</b>	IF THE SYSTEM IS NOT USED FOR AN EXTENDED PERIOD IT IS RECOMMENDED TO BE FILLED WITH A LIGHT OIL AFTER CLEANING.
-------------	--

## MX22060 &amp; MX19070 BARE PUMP

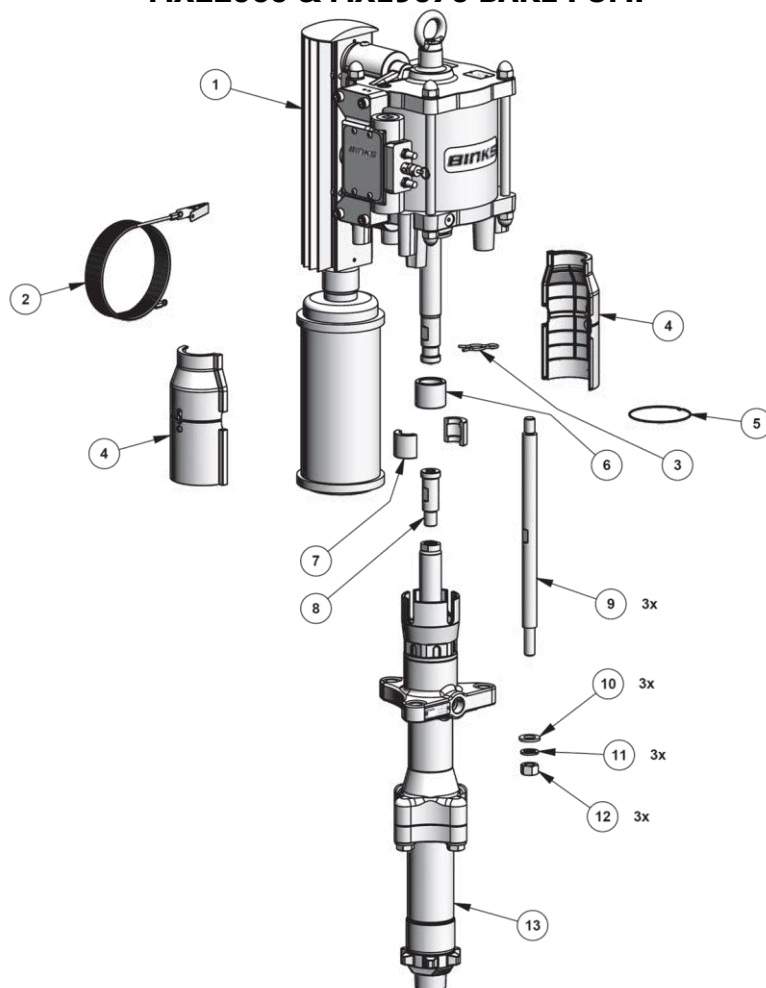

ITEM	PART NUMBER	DESCRIPTION	QUANTITY	
			MX22060	MX19070
1	AX260L-7	AX260L AIR MOTOR ASSEMBLY (7 BAR)	-	1
	AX260L-8	AX260L AIR MOTOR ASSEMBLY (8 BAR)	1	-
2	0114-011798	GROUND WIRE	1	1
3	0115-010450	HAIR PIN CLIP	1	1
4	193546	GUARD	2	2
5	193543	CLIP	1	1
6	0115-010448	SPLIT COLLAR RETAINER	1	1
7	0115-010445	MOTOR ROD SPLIT COLLAR	1	1
8	0115-010447	PUMP ROD QD ADAPTER	1	1
9	0115-010444	TIE ROD	3	3
10	165097	WASHER	3	3
11	20-6832	SPRING LOCK WASHER	3	3
12	20-6834	NUT	3	3
13	FX190XX-XXH	FX190 FLUID SECTION	-	1
	FX220XX-XXH	FX220 FLUID SECTION	1	-



**MX22060 & MX19070 BARE PUMP - MAINTENANCE**

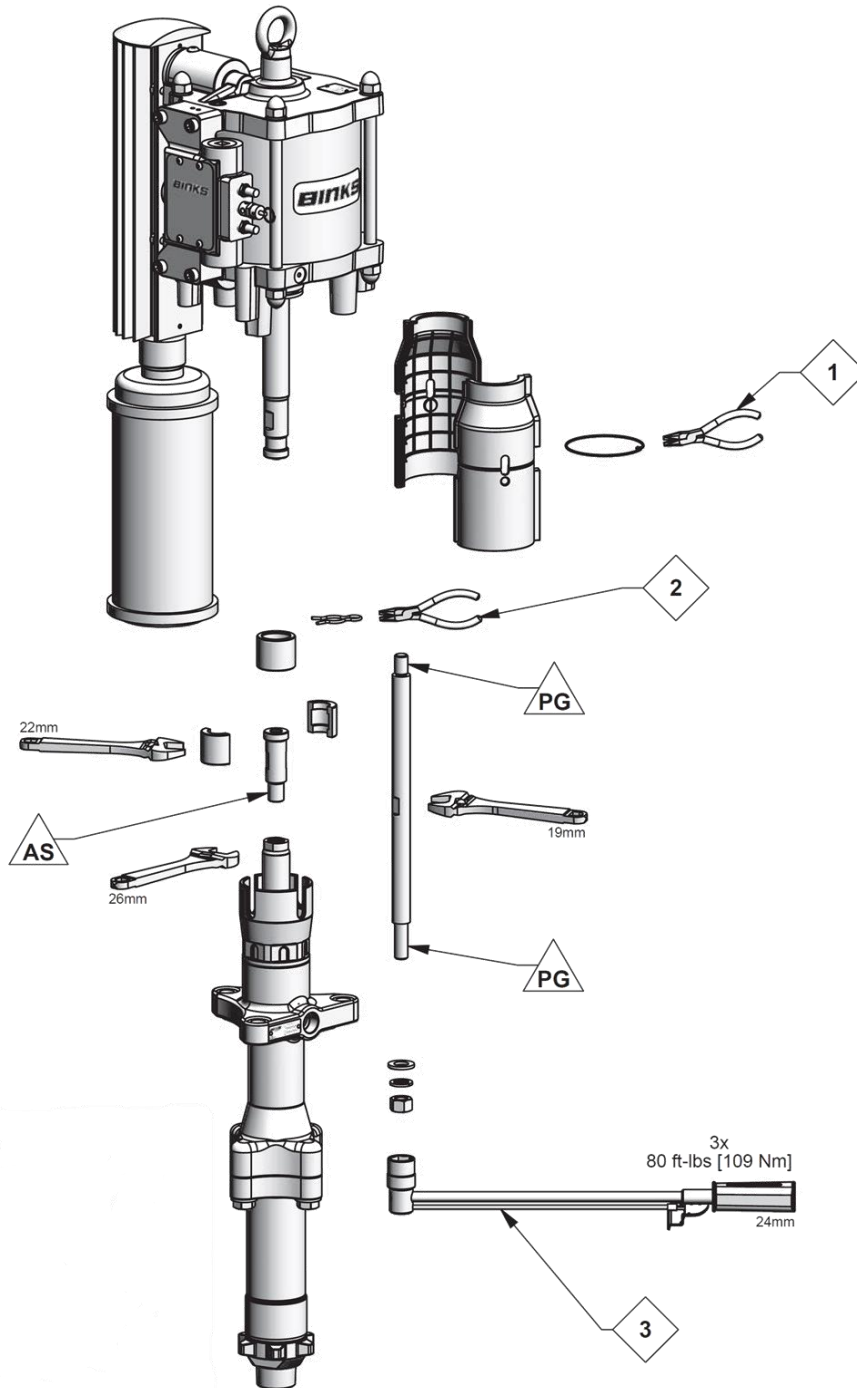

**MAINTENANCE SYMBOLS**

#	ITEM NUMBER
#	MAINTENANCE ORDER (Reverse for assembly)
PG	PETROLEUM JELLY/GREASE
AS	ANTI-SIEZE GREASE

## MX22060 & MX19070 BARE PUMP - TROUBLESHOOTING

PROBLEM	CAUSE	SOLUTION
<b>Pump will not start</b>	No compressed air. Spray tip is blocked.	Check compressed air supply. Clean or replace the spray tip.
<b>Erratic operation of air motor, air motor stops.</b>	Worn poppet assemblies. Worn or dirty spool and sleeve assembly.	Replace the poppet assemblies. Clean or replace the spool and sleeve assembly, as necessary.
<b>Continuous air leak from the exhaust</b>	Worn poppet assemblies. Worn piston seal. Worn diaphragm.	Replace poppet assemblies. Replace piston seal. Replace diaphragm.
<b>Material in solvent cup.</b>	Worn or dirty upper packings.	Replace or clean upper packings as necessary.
<b>Pump does not stop on the down stroke.</b>	Worn or dirty lower ball check.	Replace or clean the parts as necessary.
<b>Pump does not stop on the up stroke.</b>	Worn or dirty upper ball check. Worn or dirty lower packings.	Replace or clean the parts as necessary.
<b>Pump runs erratically</b>	Blocked siphon kit. Blocked inlet filter or strainer. Low material level.	Replace or clean the siphon kit. Replace or clean the inlet filter or strainer. Replace or refill material container.
<b>Pump runs , with no output.</b>	Loose connection in between pump and siphon kit. Stuck lower ball.	Check that all connections are tight. Replace or clean the parts as necessary.

**AX260L  
AIR MOTOR**



***Patent 7,603,855***

**SOUND PRESSURE LEVEL & AIR FLOW**

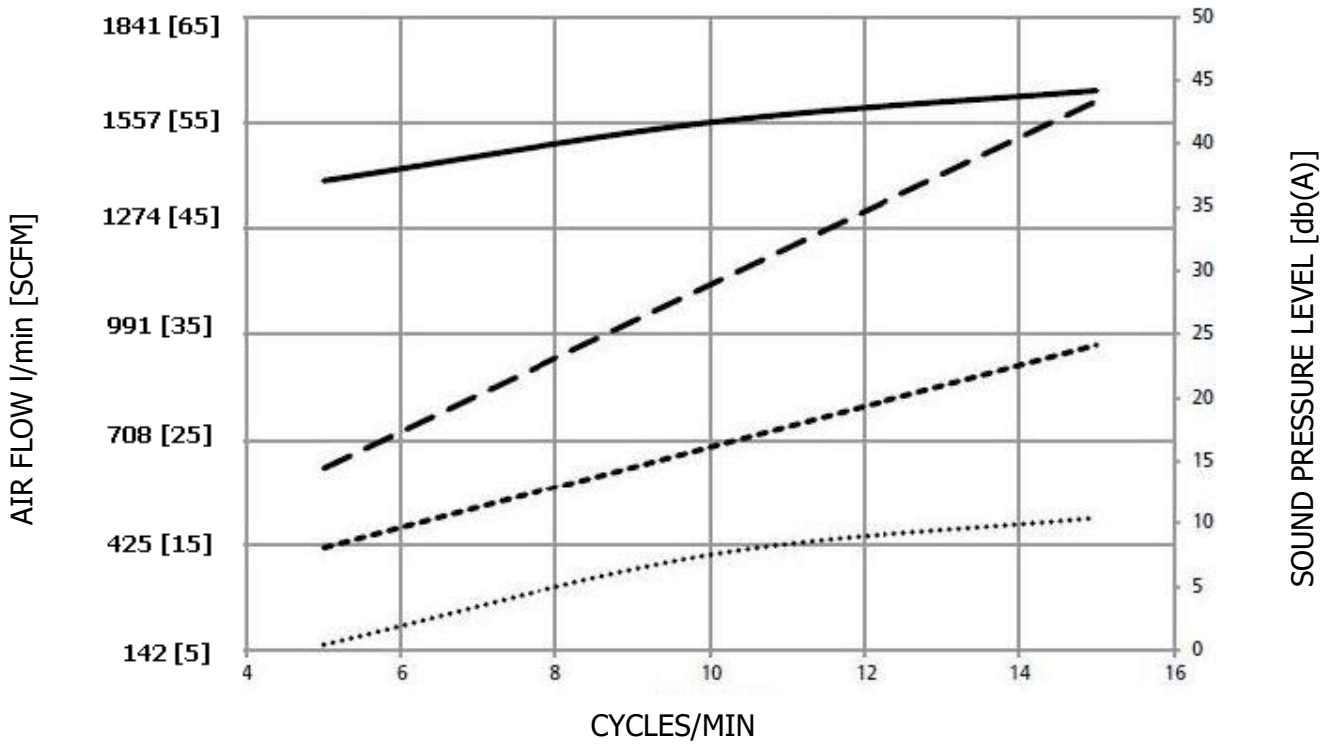

- 2.8 Bar [40 psi] AIR FLOW l/min [SCFM]
- .-. 5.5 Bar [80 psi] AIR FLOW l/min [SCFM]
- ..... 2.8 Bar [40 psi] SOUND PRESSURE LEVEL [db(A)]
- 5.5 Bar [80 psi] SOUND PRESSURE LEVEL [db(A)]

**SPECIFICATIONS**

	<b>AX260L-5</b>	<b>AX260L6</b>	<b>AX260L-7</b>	<b>AX260L-8</b>
Maximum air inlet pressure:	5 Bar [72.5 psi]	6 Bar [87 psi]	7 Bar [101.5 psi]	8 Bar [116 psi]
Maximum recommended continuous cycle rate: Cycles/min [strokes]	20 [40]			
Maximum recommended intermittent cycle rate: Cycles/min [strokes]	30 [60]			
Air inlet connection:	3/4" BSPP/NPS (f)			
Nominal pump stroke:	127mm [5"]			
Ambient temperature range	0 - 71°C [0 - 160°F]			
Weight:	35Kg [78lbs]			

### AX260L AIR MOTOR

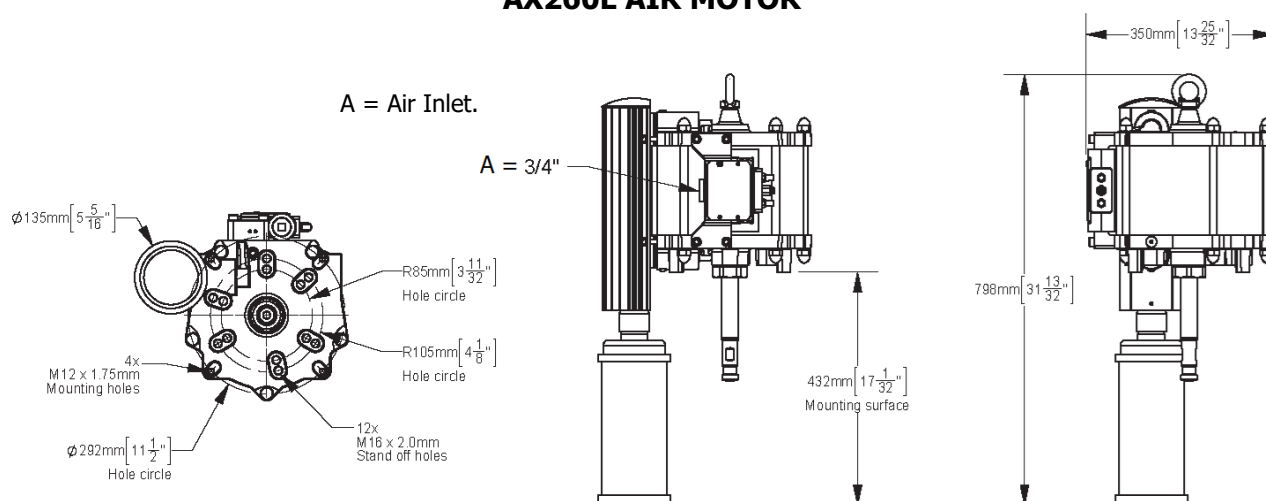

### MAINTENANCE

INSPECTION	OPERATION	
<b>Daily</b>	Check for general air leakage and correct motor operation.	
<b>6 Month Test</b>	Perform a pump stall test to ensure correct operation.	
	Perform a stall test on the pump assembly. If air is escaping through exhaust, check air motor piston seal and QEV piston, replace as required.	
<b>12 to 36 Months (Typically 10 million pump cycles, dependant on air quality)</b>	Replace air piston seal.	Order a 250645 Seal Kit.
	Replace motor rod cartridge assembly.	
	Replace poppet assemblies.	Order a 250649 Valve repair kit.
	Inspect and replace if required: Main valve assembly parts.	

### TROUBLESHOOTING

SYMPTOM	POSSIBLE CAUSE	REMEDY
<b>Motor will not run</b>	No air supply.	Check air and fluid supply ball valves and supply hoses.
	Air piston seal worn.	Replace piston seal.
	Poppet assemblies are not working.	Switch/interchange poppet assemblies to isolate the faulty poppet, and clean or replace.
	Main valve assembly is not working.	Check the main valve assembly, and clean or replace.
	QEV's are not working.	Check for constant exhaust air when pump is not in a stalled condition. Check the QEV pistons, and clean or replace.
<b>Pump runs but has excessive pulsation.</b>	Worn piston seal.	Replace piston seal.
	Worn/failed motor rod seals.	Replace motor rod cartridge assembly.
	Damaged QEV.	Inspect, clean and replace as required.
	Damaged poppet assembly.	Inspect, clean and replace as required.
	Air exhaust restricted.	Inspect, clean and replace as required.

AX260L AIR MOTOR

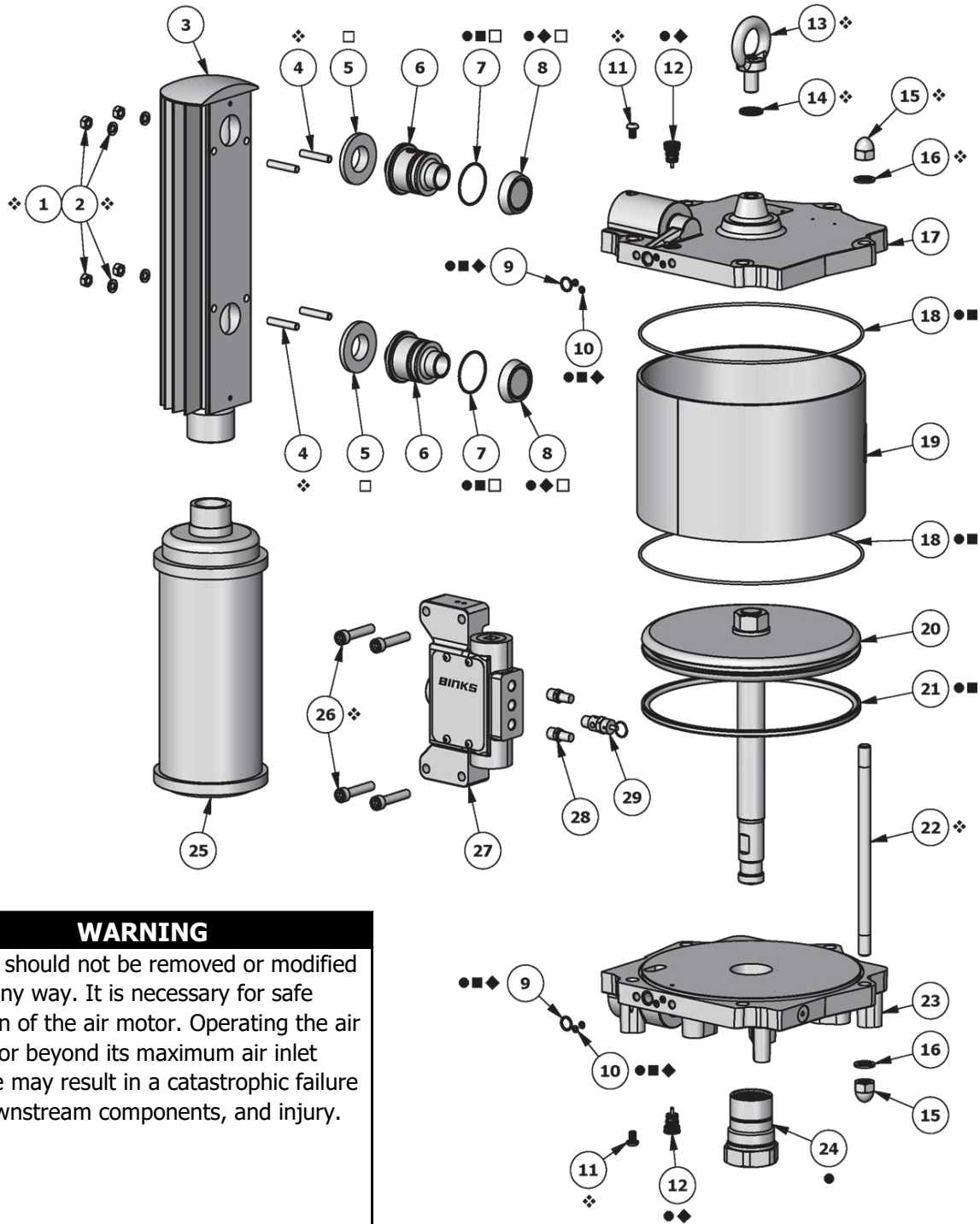

**⚠ WARNING**  
 Item 29 should not be removed or modified in any way. It is necessary for safe operation of the air motor. Operating the air motor beyond its maximum air inlet pressure may result in a catastrophic failure of downstream components, and injury.

- Parts are included in 250645 Seal Kit.
- Parts are included in 250648 Cylinder seal kit.
- ◆ Parts are included in 250649 Valve repair kit.
- ❖ Parts are included in 250650 Hardware kit.
- Parts are included in 250651 Exhaust seal kit.

Recommended grease p/n: AGMD-010.

**AX260L  
AIR MOTOR**

ITEM NO.	PART NO.	DESCRIPTION	QTY	COMMENTS
1	192049	M8 HEX NUT S.S.	4	❖
2	165108	M8 LOCKWASHER S.S.	4	❖
3	193159	EXHAUST MANIFOLD ASSEMBLY	1	
4	165994	M8 X 44 STUD S.S.	4	❖
5	193363	EXHAUST GASKET	2	□
6	193320	QEV CAP	2	
7	162765	O-RING 2 X 46	2	●■□
8	0115-010463	QEV PISTON	2	●◆□
9	162766	O-RING 2 X 13	2	●■◆
10	0115-010051	O-RING 2 X 4	4	●■◆
11	177000	M8 X 12MM BUTTON HEAD SCREW S.S.	2	❖
12	0115-010037	POPPET ASSEMBLY	2	●◆
13	192441	M16 EYE BOLT	1	❖
14	165100	M16 LOCKWASHER S.S.	1	❖
15	165981	M14 X 2 DOME NUT S.S.	10	❖
16	165982	M14 LOCKWASHER	10	❖
17	0115-010404	UPPER END CAP	1	
18	162768	O-RING 3 X 261	2	●■
19	0115-010341	CYLINDER	1	
20 *	194066	PISTON	1	
21	0115-010351	PISTON WASHER	1	●■
22	193150	TIE ROD	5	❖
23	0115-010405	LOWER END CAP	1	
24	193249	MOTOR ROD CARTRIDGE ASSEMBLY	1	●
25	192509	SILENCER	1	
26	165567	M10 X 50 SOCKET HEAD CAP SCREW S.S.	4	❖
27	0115-010471	MAIN VALVE ASSEMBLY	1	
28	0115-010443	VALVE MUFFLER	2	
29	0114-014716	PRESSURE RELIEF VALVE 72 psi [5 bar]	1	AX260L-5
	193538	PRESSURE RELIEF VALVE 87 psi [6 bar]		AX260L-6
	193539	PRESSURE RELIEF VALVE 101 psi [7 bar]		AX260L-7
	0114-014774	PRESSURE RELIEF VALVE 116 psi [8 bar]		AX260L-8

\* Item 21 is also contained within item 20.

**0115-010471**  
**MAIN VALVE ASSEMBLY**

ITEM NO.	PART NO.	DESCRIPTION	QTY	COMMENTS
30	165990	M8 X 55 SOCKET HEAD CAP SCREW S.S.	4	◆❖
31	0115-010456	MANIFOLD	1	
32	0115-010460	GASKET	1	●■◆
33	0115-010425	VALVE BLOCK END CAP	2	◆
34	162767	O-RING 2 X 30	2	●■◆
35	0115-010428	MAGNET	2	◆
36	0115-010427	BUMPER	2	◆
37	0115-010431	SPACER	2	◆
38	0115-010424	SPOOL AND SLEEVE ASSEMBLY.	1	◆
39	0115-010454	VALVE BLOCK.	1	●■◆

- Parts are included in 250645 Seal Kit.
- Parts are included in 250648 Cylinder seal kit.
- ◆ Parts are included in 250649 Valve repair kit.
- ❖ Parts are included in 250650 Hardware kit.
- Parts are included in 250651 Exhaust seal kit.

Recommended grease p/n: AGMD-010.



# AX260L AIR MOTOR - MAINTENANCE

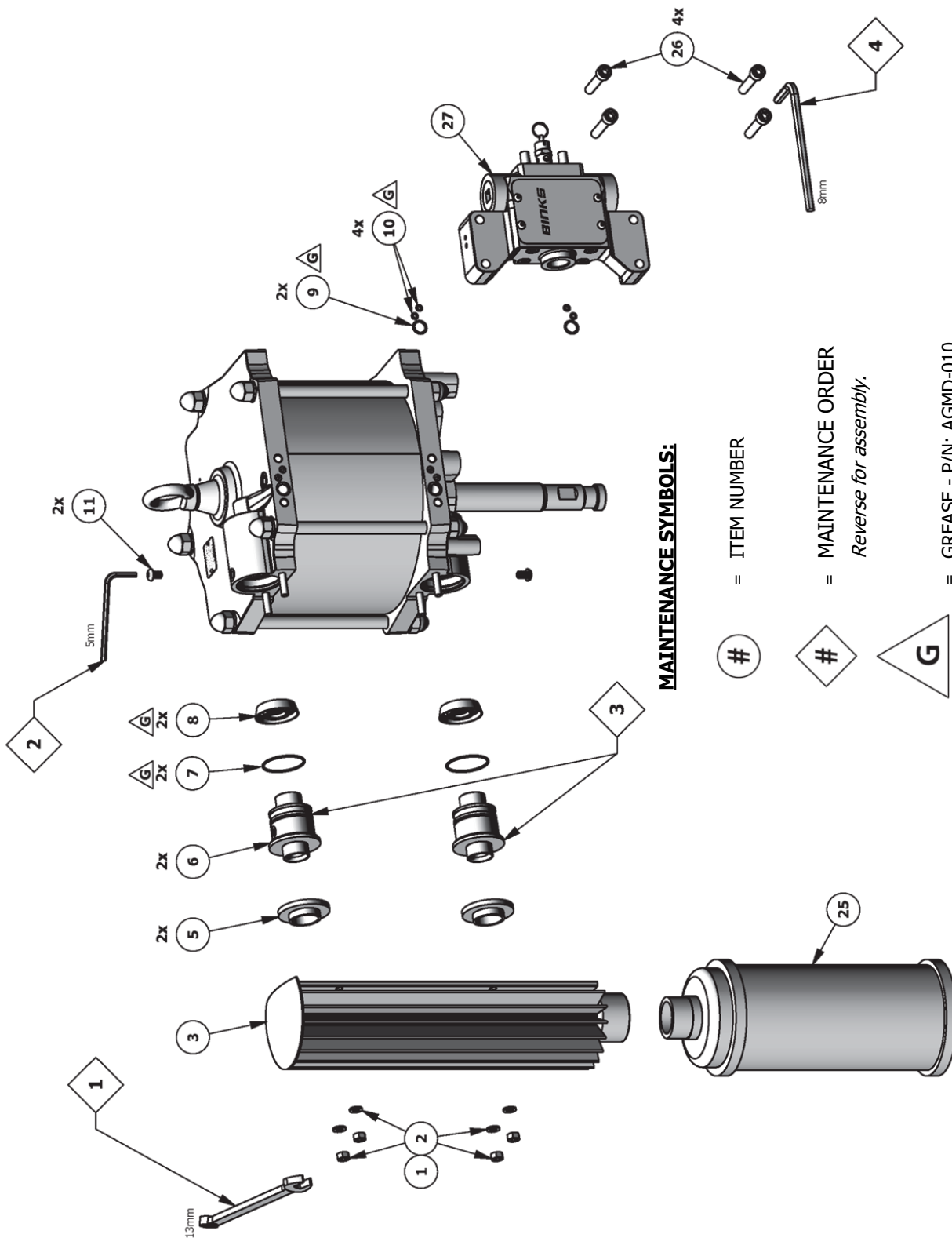



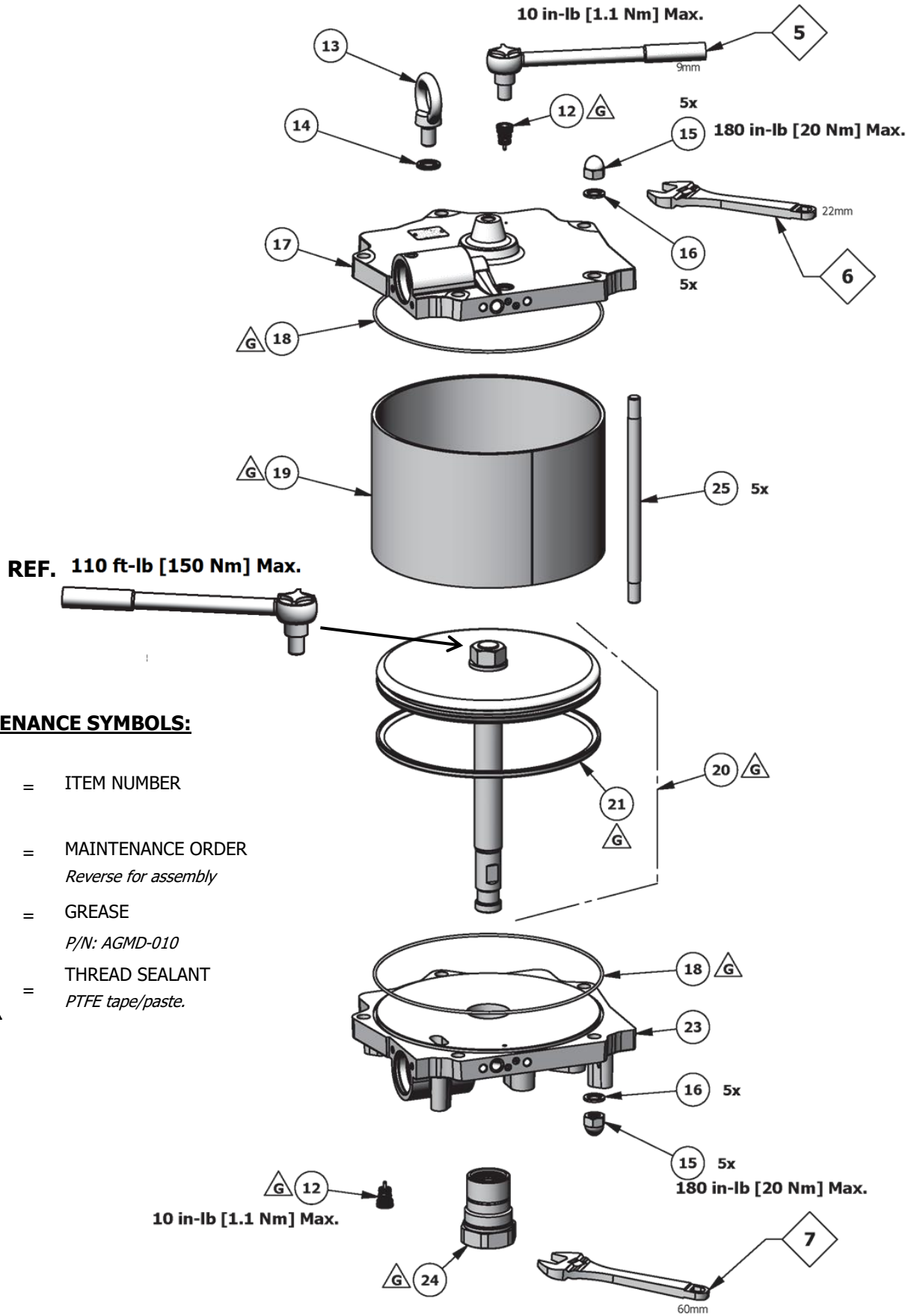

**MAINTENANCE SYMBOLS:**

- # = ITEM NUMBER
- # = MAINTENANCE ORDER  
*Reverse for assembly.*
- G = GREASE - P/N: AGMD-010
- TS = THREAD SEALANT PTFE tape/paste

AX260L AIR MOTOR - MAINTENANCE



**MAINTENANCE SYMBOLS:**

-  = ITEM NUMBER
-  = MAINTENANCE ORDER  
*Reverse for assembly*
-  = GREASE  
*P/N: AGMD-010*
-  = THREAD SEALANT  
*PTFE tape/paste.*

AX260L AIR MOTOR - MAINTENANCE



DANGER



You are in the presence of magnetic fields which may interfere with the operation of certain pacemakers

CAUTION

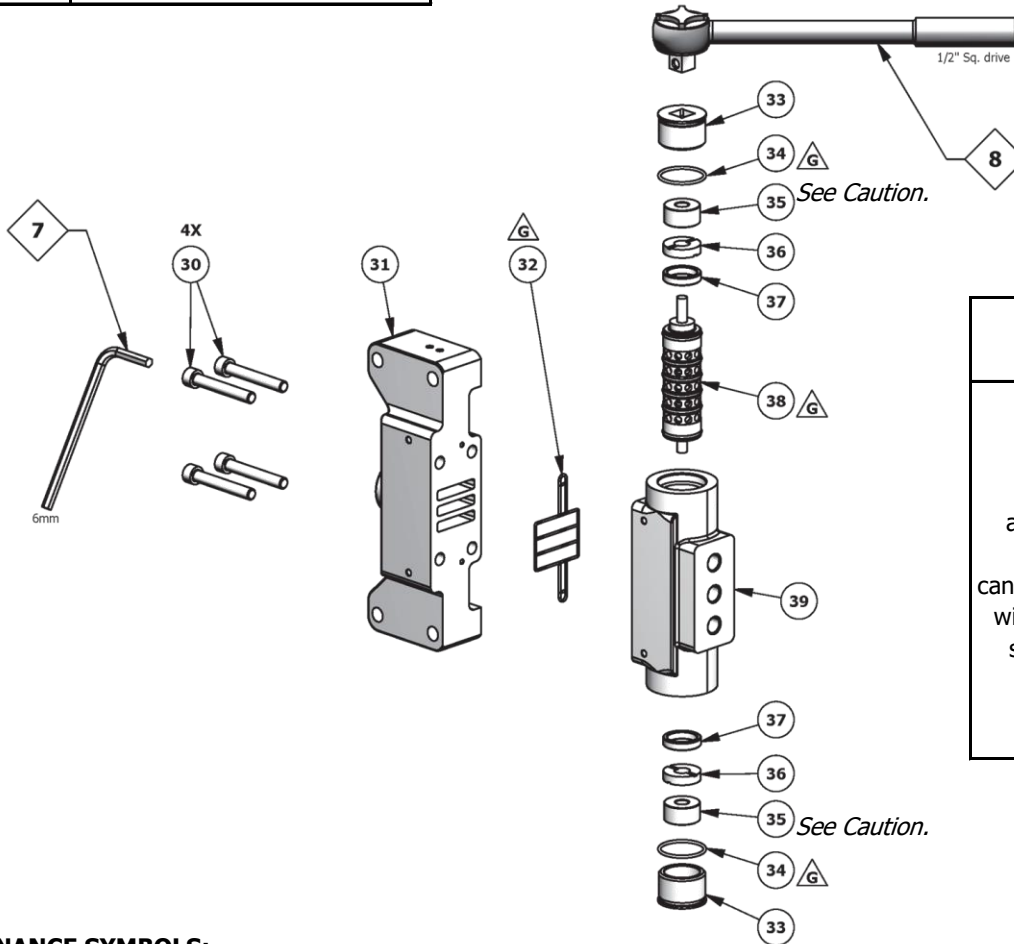
Take care when handling the magnets (35). Avoid getting magnets in close proximity to each other. Injury or damage to magnets may result.



NOTE

Spool and sleeve assembly (38) is a matched set and cannot be interchanged with other spool and sleeve assemblies.

**MAINTENANCE SYMBOLS:**

- # = ITEM NUMBER
- # = MAINTENANCE ORDER  
*Reverse for assembly*
- G = GREASE  
*P/N: AGMD-010*
- TS = THREAD SEALANT

**AX260L  
SERVICE KITS**

ITEM NO.	PART NO.	DESCRIPTION	●	■	◆	❖	□
			250645	250648	250649	250650	250651
			MOTOR SEAL KIT	CYLINDER SEAL KIT	VALVE SEAL KIT	HARDWARE KIT	EXHAUST SEAL KIT
1	192049	M8 HEX NUT S.S.				4	
2	165108	M8 LOCKWASHER S.S.				4	
4	165994	M8 x 1.25 x 44mm STUD S.S.				4	
5	193363	EXHAUST GASKET					2
7	162765	O-RING 2 X 46mm	2	2			2
8	0115-010463	QEV PISTON	2		2		2
9	162766	O-RING 2 X 13mm	2	2	2		
10	0115-010051	O-RING 2 X 4mm	4	4	4		
11	177000	M8 x 1.25 x 12mm BUTTON HEAD SCREW S.S.				2	
12	0115-010037	POPPET ASSEMBLY	2		2		
13	192441	M16 EYE BOLT				1	
14	165100	M16 LOCKWASHER S.S.				1	
15	165981	M14 X 2mm DOME NUT S.S.				10	
16	165982	M14 LOCKWASHER				10	
18	162768	O-RING 3 X 261	2	2			
21	0115-010351	GLYDE RING	1	1			
22	193150	AIR MOTOR TIE ROD				5	
24	193249	MOTOR ROD CARTRIDGE ASSEMBLY	1				
26	165567	M10 X 50mm SOCKET HEAD CAP SCREW S.S.				4	
30	165990	M8 x 1.25 x 55mm SOCKET HEAD CAP SCREW S.S.			4	4	
32	0115-010460	GASKET	1	1	1		
33	0115-010425	VALVE BLOCK END CAP			2		
34	162767	O-RING 2 X 30mm	2	2	2		
35	0115-010428	MAGNET			2		
36	0115-010427	BUMPER			2		
37	0115-010431	SPACER			2		
38	0115-010424	SPOOL AND SLEEVE ASSEMBLY.			1		

## FX190 AND FX220 FLUID PUMP

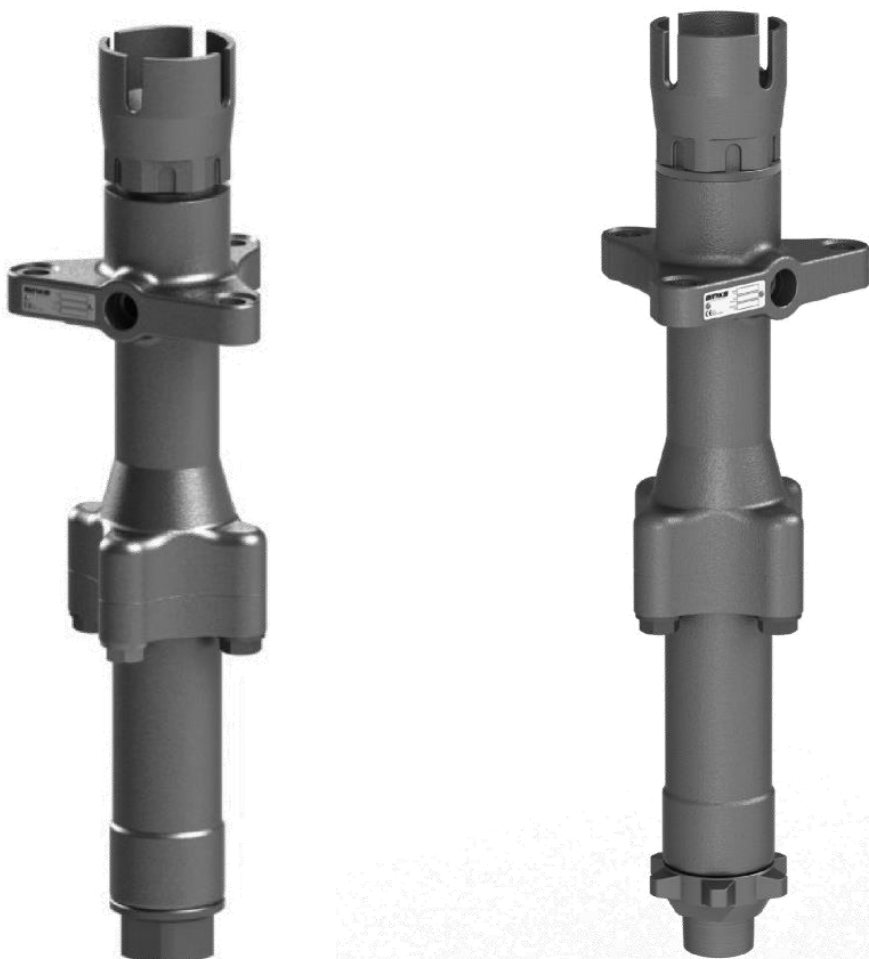

### SPECIFICATION

		FX190	FX220
Output @ 60 cycles/min:		11.4 l/m [3.0 gpm]	13.2 l/m [3.5 gpm]
Displacement per cycle:		190 cc [6.4 oz]	220 cc [7.4 oz]
Maximum fluid pressure:		500 bar [7250 psi]	
Ambient operating temperature:		0 - 71° C [0 - 160 °F]	
Stroke length:		127mm [5 in]	
<b>A</b>	Inlet size:	1 1/4" NPT (f) / 1 1/2" NPT (m)	
<b>B</b>	Outlet size:	3/4" NPT (f)	
Weight:		20.3 kg [44.7 lbs]	
Wetted parts materials of construction (Carbon Steel models):		Nickel plated Carbon Steel, Stainless Steel, Ceramic coated Stainless Steel, PTFE, UHMWPE, Leather, Tungsten Carbide.	
Wetted parts materials of construction (Stainless Steel models):		Stainless Steel, Ceramic coated Stainless Steel, PTFE, UHMWPE, Leather, Tungsten Carbide.	

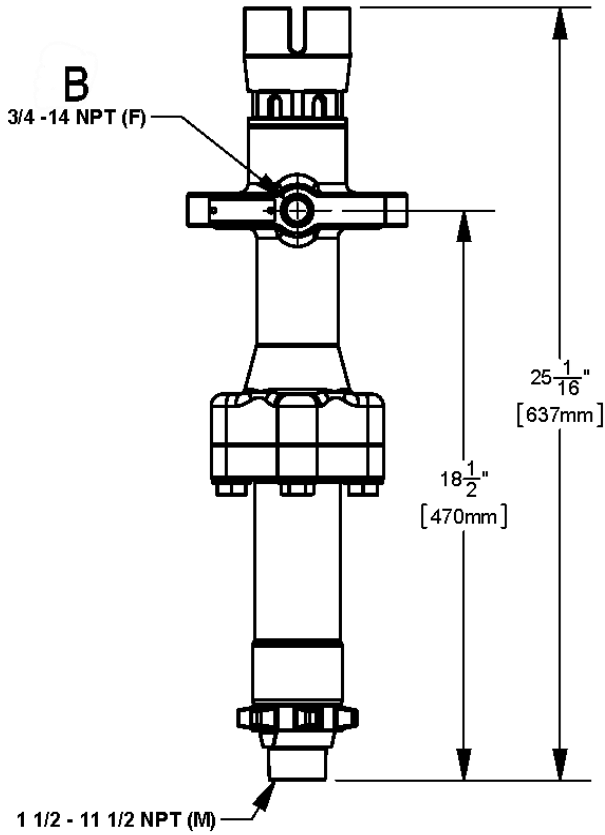
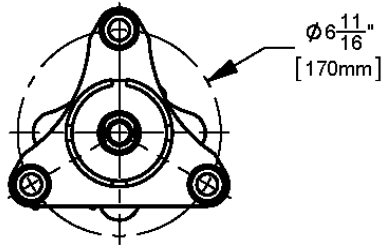

**KNOCK-OFF INLET OPTION**

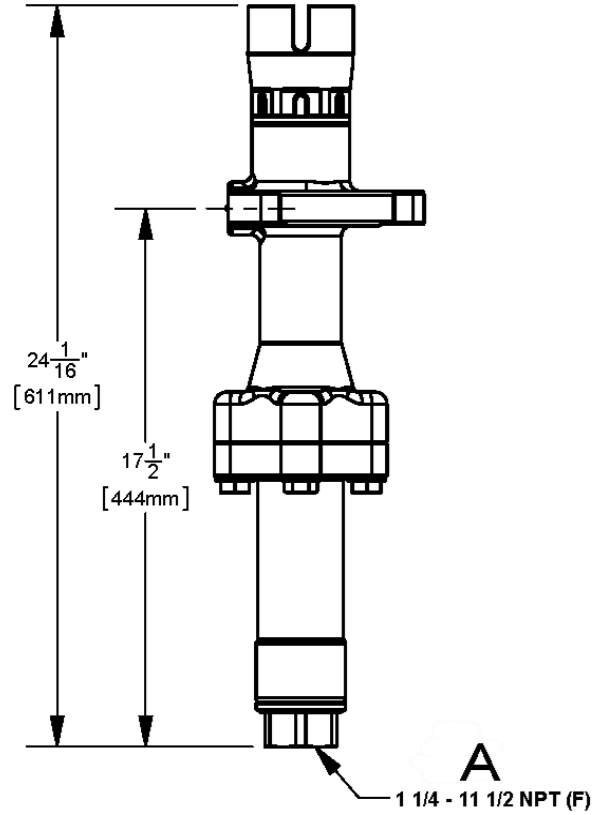

**HEXAGON INLET OPTION**

**FLUID SECTION PART NUMBER SELECTOR**

**FX190 PL - C A H**

FX190 - 190 ml/CYCLE

PL - PTFE/LEATHER

C-CARBON STEEL

A - AUTO PACKING  
ADJUSTMENT

FX220 - 220 ml/CYCLE

PP - PTFE

S - STAINLESS STEEL

PU - PTFE/UHMW

UU - UHMW

UL - UHMW/LEATHER

M - MANUAL PACKING  
ADJUSTMENT

FX190 & FX220 FLUID PUMP

PACKING ADJUSTMENT OPTIONS

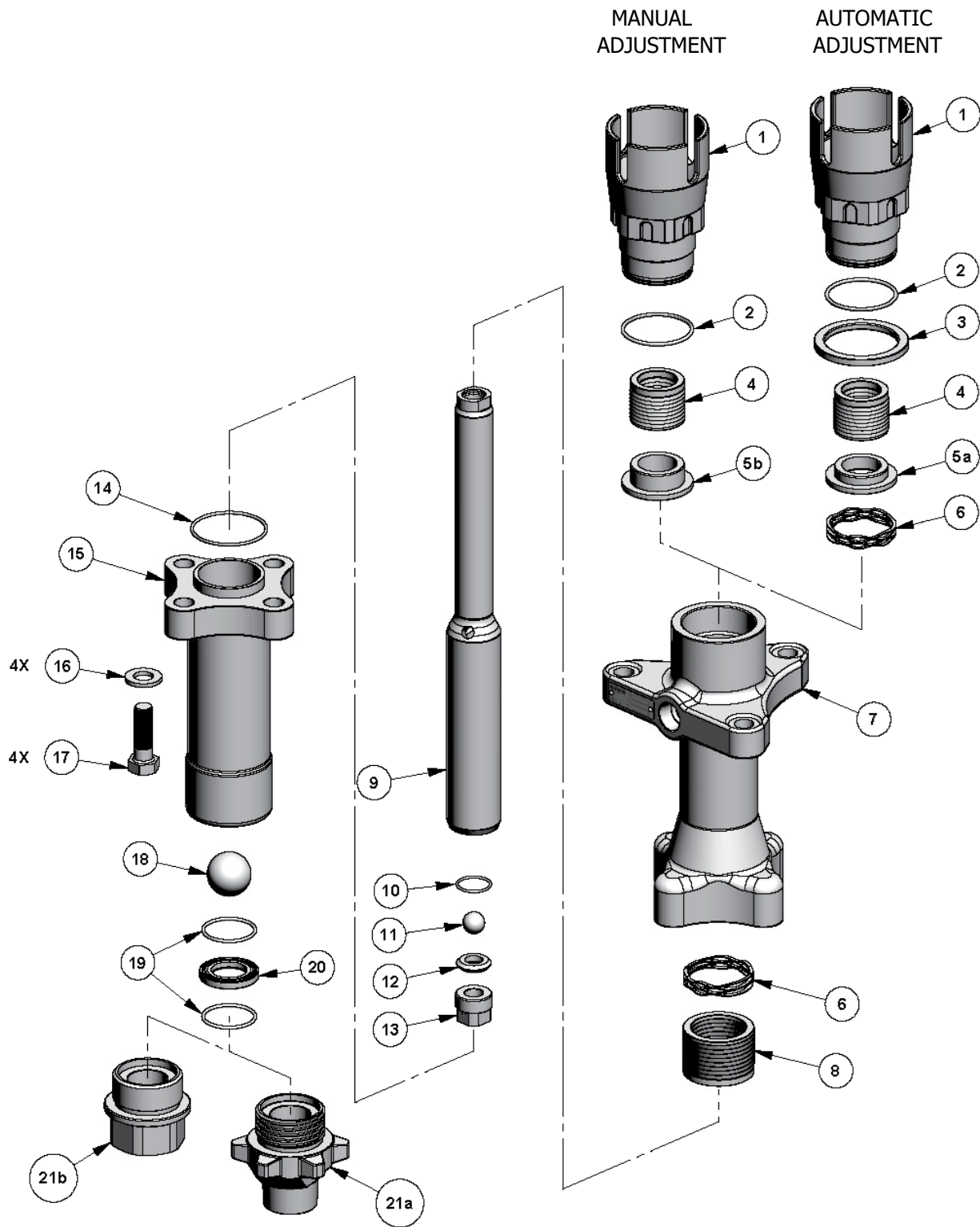

HEXAGON INLET

KNOCK OFF INLET

FLUID INLET OPTIONS

## FX190 & FX220 FLUID PUMP

**EN**



ITEM NO.	PART NO.	DESCRIPTION	QTY	COMMENTS
1	193295	PACKING NUT	1	
2	162773	O-RING Ø57mm	1	
3	193298	PACKING SPACER	1	Auto only
4	193296	FX220 UPPER PACKING ASSEMBLY (UHMW)	1	FX220 only
	193303	FX220 UPPER PACKING ASSEMBLY (PTFE)	1	FX220 only
	193308	FX220 UPPER PACKING ASSEMBLY (PTFE/LEATHER)	1	FX220 only
	193313	FX220 UPPER PACKING ASSEMBLY (UHMW/PTFE)	1	FX220 only
	193770	FX220 UPPER PACKING ASSEMBLY (UHMW/LEATHER)	1	FX220 only
	193508	FX190 UPPER PACKING ASSEMBLY (UHMW/PTFE)	1	FX190 only
	193505	FX190 UPPER PACKING ASSEMBLY (PTFE)	1	FX190 only
	193506	FX190 UPPER PACKING ASSEMBLY (PTFE/LEATHER)	1	FX190 only
	193507	FX190 UPPER PACKING ASSEMBLY (UHMW)	1	FX190 only
193772	FX190 UPPER PACKING ASSEMBLY (UHMW/LEATHER)	1	FX190 only	
5a	193299	PACKING LOADER	1	Auto only
5b	193301	PACKING LOADER	1	Manual only
6	41-28038	PACKING SPRING	2	1 for Manual adj.
7	193326	UPPER HOUSING (CARBON STEEL)	1	
	193285	UPPER HOUSING (STAINLESS STEEL)	1	
8	193294	FX220 LOWER PACKING ASSEMBLY (UHMW)	1	FX220 only
	193305	FX220 LOWER PACKING ASSEMBLY (PTFE)	1	FX220 only
	193310	FX220 LOWER PACKING ASSEMBLY (PTFE/LEATHER)	1	FX220 only
	193314	FX220 LOWER PACKING ASSEMBLY (UHMW/PTFE)	1	FX220 only
	193771	FX220 LOWER PACKING ASSEMBLY (UHMW/LEATHER)	1	FX220 only
	193501	FX190 LOWER PACKING ASSEMBLY (PTFE)	1	FX190 only
	193503	FX190 LOWER PACKING ASSEMBLY (UHMW)	1	FX190 only
	193504	FX190 LOWER PACKING ASSEMBLY (UHMW/PTFE)	1	FX190 only
	193502	FX190 LOWER PACKING ASSEMBLY (PTFE/LEATHER)	1	FX190 only
193773	FX190 LOWER PACKING ASSEMBLY (UHMW/LEATHER)	1	FX190 only	
9	193287	FX220 PUMP ROD	1	FX220 only
	193500	FX190 PUMP ROD	1	FX190 only
10	162770	O-RING Ø27mm	1	
11	171790	3/4" BALL	1	
12	193288	3/4" BALL SEAT	1	
13	193289	SEAT RETAINER	1	
14	162772	O-RING Ø62mm	1	
15	193327	LOWER HOUSING (CARBON STEEL)	1	
	193286	LOWER HOUSING (STAINLESS STEEL)	1	
16	165097	WASHER	4	
17	165369	HEX HEAD CAP SCREW	4	
18	191791	1-1/2" BALL	1	
19	162771	O-RING Ø45mm	2	
20	193290	1-1/2" SEAT ASSEMBLY	1	
21a	193334	FLUID INLET (KNOCK-OFF)	1	
21b	193468	FLUID INLET (HEXAGON)	1	

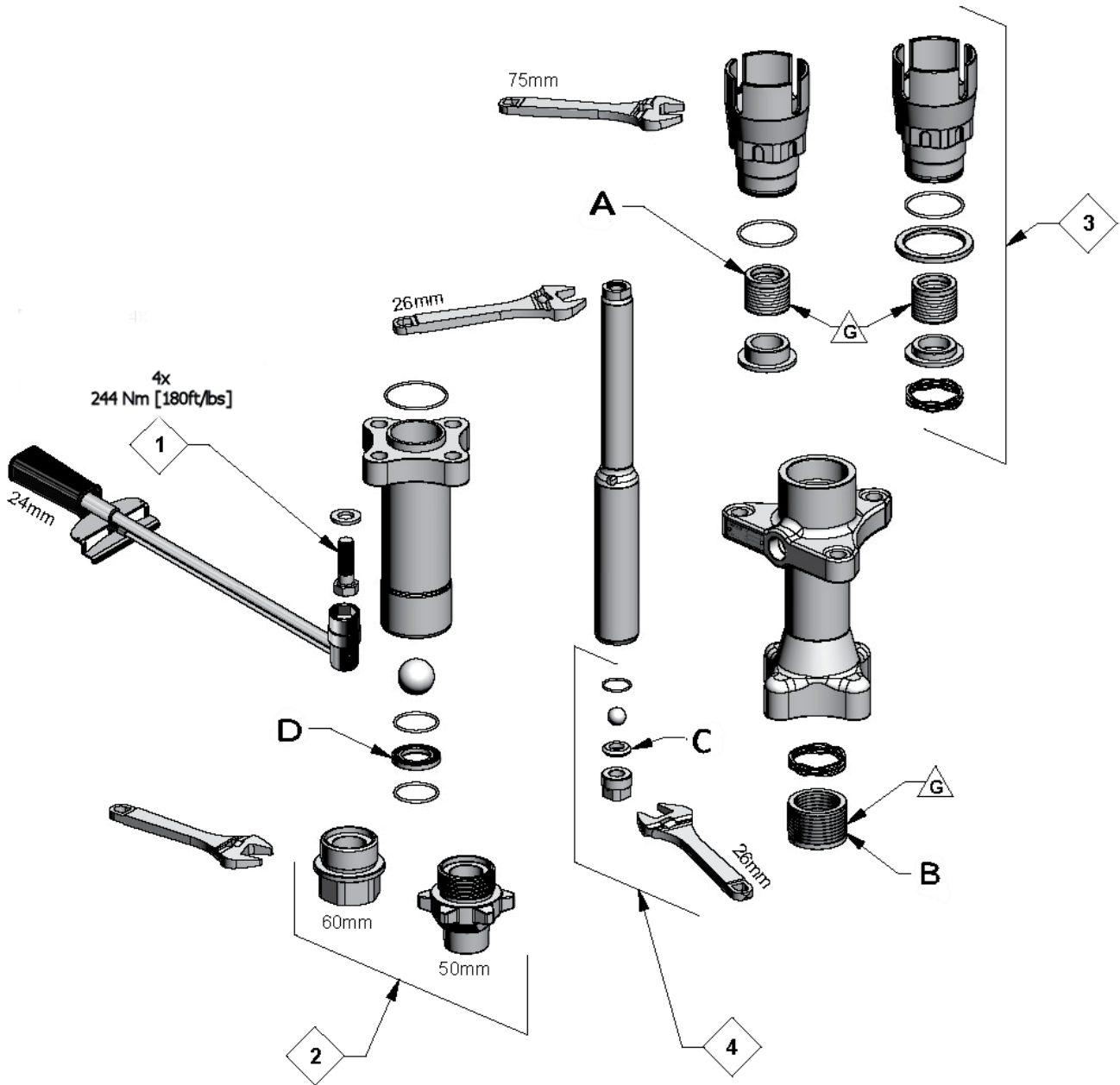

**FX190 & FX220 FLUID PUMP ASSEMBLIES**



**MAINTENANCE SYMBOLS:**

-  = ITEM NUMBER
-  = MAINTENANCE ORDER  
*Reverse for assembly.*
-  = GREASE - P/N: AGMD-010

**FX190 & FX220 FLUID PUMP ASSEMBLIES**

DETAIL "A"  
UPPER PACKING ORIENTATIONS

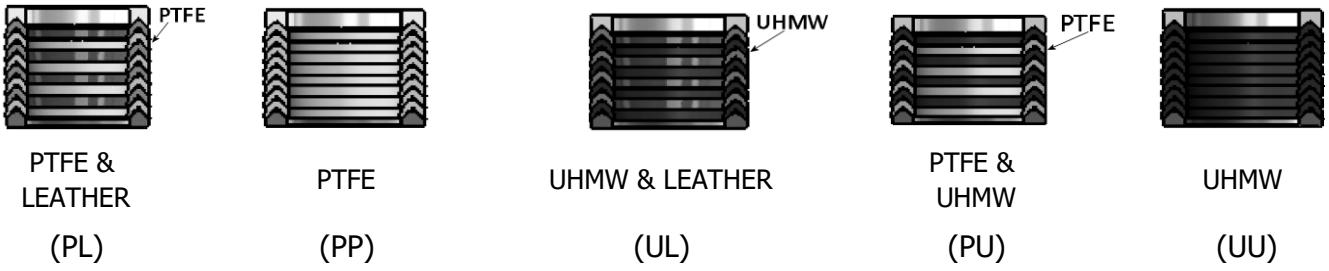

DETAIL "B"  
LOWER PACKING ORIENTATIONS



ASSEMBLY NOTE: LIGHTLY APPLY GREASE TO PACKINGS BEFORE INSERTING INTO PUMP

DETAIL "C"  
UPPER BALL SEAT ORIENTATION

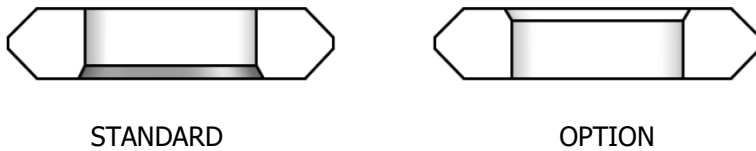

NOTE: SEAT IS REVERSIBLE

DETAIL "D"  
LOWER BALL SEAT ORIENTATION

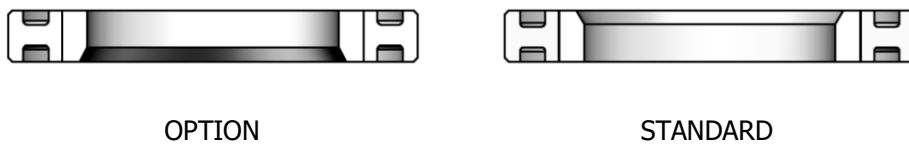

NOTE: SEAT IS REVERSIBLE

**FX190/220 BALL AND SEAL KITS**

ITEM NO.	PART NO.	DESCRIPTION	250692	250693
			Upper ball & seat	Lower ball & seat
11	171790	3/4" BALL	1	
12	193288	3/4" BALL SEAT	1	
18	191791	1-1/2" BALL		1
20	193290	1-1/2" SEAT ASSEMBLY		1

Recommended grease: AGMD-011

Recommended packing lubricants: 0114-009433 for Solvent based materials

0114-014871 for Water based materials

FX220 SEAL KITS

ITEM NO.	PART NO.	DESCRIPTION	250658	250659	250666	250667	250688
			PTFE/LEATHER - Seal Kit	PTFE/UHMW - Seal Kit	PTFE - Seal Kit	UHMW - Seal Kit	UHMW/LEATHER - Seal Kit
2	162773	O-RING Ø52mm	1	1	1	1	1
4	193296	FX220 UPPER PACKING ASSEMBLY (UHMW)				1	
	193303	FX220-UPPER PACKING ASSEMBLY (PTFE)			1		
	193308	FX220 UPPER PACKING ASSEMBLY (PTFE/LEATHER)	1				
	193313	FX220 UPPER PACKING ASSEMBLY (PTFE/UHMW)		1			
	193770	FX220 UPPER PACKING ASSEMBLY (UHMW/LEATHER)					1
8	193294	FX220 LOWER PACKING ASSEMBLY (UHMW)				1	
	193305	FX220 LOWER PACKING ASSEMBLY (PTFE)			1		
	193310	FX220 LOWER PACKING ASSEMBLY (PTFE/LEATHER)	1				
	193314	FX220 LOWER PACKING ASSEMBLY (PTFE/UHMW)		1			
	193771	FX220 LOWER PACKING ASSEMBLY (UHMW/LEATHER)					1
10	162770	O-RING Ø27mm	1	1	1	1	1
14	162772	O-RING Ø62mm	1	1	1	1	1
19	162771	O-RING Ø45mm	2	2	2	2	2

**FX220 SEAL KITS**

**EN**

250660 250661 250668 250669 250689

ITEM NO.	PART NO.	DESCRIPTION	PTFE/LEATHER - Rebuild Kit	PTFE/UHMW - Rebuild Kit	PTFE - Rebuild Kit	UHMW - Rebuild Kit	UHMW/LEATHER - Rebuild Kit
2	162773	O-RING Ø52mm	1	1	1	1	1
4	193296	FX220 UPPER PACKING ASSEMBLY (UHMW)				1	
	193303	FX220-UPPER PACKING ASSEMBLY (PTFE)			1		
	193308	FX220 UPPER PACKING ASSEMBLY (PTFE/LEATHER)	1				
	193313	FX220 UPPER PACKING ASSEMBLY (PTFE/UHMW)		1			
	193770	FX220 UPPER PACKING ASSEMBLY (UHMW/LEATHER)					1
8	193294	FX220 LOWER PACKING ASSEMBLY (UHMW)				1	
	193305	FX220 LOWER PACKING ASSEMBLY (PTFE)			1		
	193310	FX220 LOWER PACKING ASSEMBLY (PTFE/LEATHER)	1				
	193314	FX220 LOWER PACKING ASSEMBLY (PTFE/UHMW)		1			
	193771	FX220 LOWER PACKING ASSEMBLY (UHMW/LEATHER)					1
10	162770	O-RING Ø27mm	1	1	1	1	1
11	171790	3/4" BALL	1	1	1	1	1
12	193288	3/4" BALL SEAT	1	1	1	1	1
14	162772	O-RING Ø62mm	1	1	1	1	1
18	191791	1-1/2" BALL	1	1	1	1	1
19	162771	O-RING Ø45mm	2	2	2	2	
20	193290	1-1/2" SEAT ASSEMBLY	1	1	1	1	1

**FX190 SEAL KITS**

ITEM NO.	PART NO.	DESCRIPTION	250662	250663	250670	250671	250690
			PTFE/LEATHER - Seal Kit	PTFE/UHMW - Seal Kit	PTFE - Seal Kit	UHMW - Seal Kit	UHMW/LEATHER - Seal Kit
2	162773	O-RING Ø52mm	1	1	1	1	1
4	193505	FX190-UPPER PACKING ASSEMBLY (PTFE)			1		
	193506	FX190 UPPER PACKING ASSEMBLY (PTFE/LEATHER)	1				
	193507	FX190 UPPER PACKING ASSEMBLY (UHMW)				1	
	193508	FX190 UPPER PACKING ASSEMBLY (PTFE/UHMW)		1			
	193372	FX190 UPPER PACKING ASSEMBLY (UHMW/LEATHER)					1
8	193501	FX190 LOWER PACKING ASSEMBLY (PTFE)			1		
	193502	FX190 LOWER PACKING ASSEMBLY (PTFE/LEATHER)	1				
	193503	FX190 LOWER PACKING ASSEMBLY (UHMW)				1	
	193504	FX190 LOWER PACKING ASSEMBLY (PTFE/UHMW)		1			
	193773	FX190 LOWER PACKING ASSEMBLY (UHMW/LEATHER)					1
10	162770	O-RING Ø27mm	1	1	1	1	1
14	162772	O-RING Ø62mm	1	1	1	1	1
19	162771	O-RING Ø45mm	2	2	2	2	2

## FX190 REPAIR KITS

250664 250665 250672 250673 250691

ITEM NO.	PART NO.	DESCRIPTION					
			PTFE/LEATHER - Seal Kit	PTFE/UHMW - Seal Kit	PTFE - Seal Kit	UHMW - Seal Kit	UHMW/LEATHER - Seal Kit
2	162773	O-RING Ø52mm	1	1	1	1	1
4	193505	FX190-UPPER PACKING ASSEMBLY (PTFE)			1		
	193506	FX190 UPPER PACKING ASSEMBLY (PTFE/LEATHER)	1				
	193507	FX190 UPPER PACKING ASSEMBLY (UHMW)				1	
	193508	FX190 UPPER PACKING ASSEMBLY (PTFE/UHMW)		1			
	193372	FX190 UPPER PACKING ASSEMBLY (UHMW/LEATHER)					1
8	193501	FX190 LOWER PACKING ASSEMBLY (PTFE)			1		
	193502	FX190 LOWER PACKING ASSEMBLY (PTFE/LEATHER)	1				
	193503	FX190 LOWER PACKING ASSEMBLY (UHMW)				1	
	193504	FX190 LOWER PACKING ASSEMBLY (PTFE/UHMW)		1			
	193773	FX190 LOWER PACKING ASSEMBLY (UHMW/LEATHER)					1
10	162770	O-RING Ø27mm	1	1	1	1	1
11	171790	3/4" BALL	1	1	1	1	1
12	193288	3/4" BALL SEAT	1	1	1	1	1
14	162772	O-RING Ø62mm	1	1	1	1	1
18	191791	1-1/2" BALL	1	1	1	1	
19	162771	O-RING Ø45mm	2	2	2	2	
20	193290	1-1/2" SEAT ASSEMBLY	1	1	1	1	

### TROUBLESHOOTING

SYMPTOM	POSSIBLE CAUSE	REMEDY
Material in solvent cup	Worn or dirty upper packings.	Replace or Clean
Pump does not stop on the down stroke.	Worn or dirty lower ball check.	Replace or Clean
Pump does not stop on the up stroke	Worn or dirty upper ball check.	
		Worn or dirty lower packings.
Pump runs erratically	Blocked material suction kit.	Replace or Clean
	Blocked inlet filter or strainer.	Replace or Clean
	Low material level.	Replace or Clean
	Worn or dirty lower ball check.	Replace or Clean
	Worn or dirty upper ball check.	

### Packing Recommendation

Packing Material	Recommendation
PU (PTFE & UHMW)	Most materials
PL (PTFE & Leather)	High temperature applications
PP (PTFE)	UV and acid based materials
UC (U-Cups)	Low friction applications

## MX22060 & MX19070 CART MOUNTED PUMP

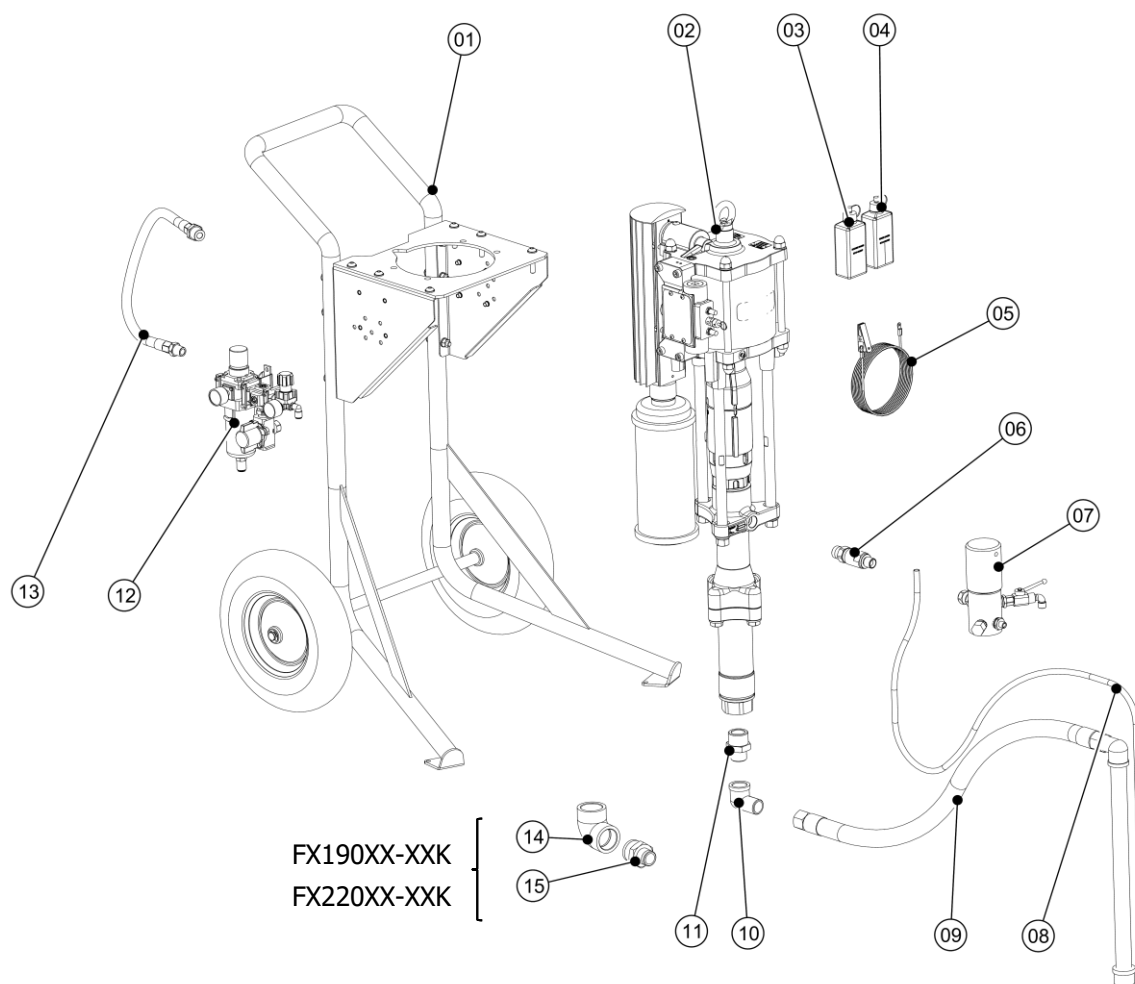

\*= OPTIONS

ITEM	PART NUMBER	DESCRIPTION	QTY
1	104084	CART	1
2	MX____-__	MX19042/22060 PUMP	1
3	0114-016099	LUBRICATION-SOLVENT BASED 0.25l	1
4	0114-016100	LUBRICATION-WATER BASED 0.25l	1
5	0114-011798	Grounding cable 4m	1
6	193791	CHECK VALVE	1
7	0114-011760	HP FILTER (100 mesh) TYPE 11	1
8	0110-009103	DUMP HOSE	2M
9	MXA-S25ME30	SUCTION HOSE ASSEMBLY 25 LITRE - 30 MESH	1
	MXA-S210ME30	SUCTION HOSE ASSEMBLY 210 LITRE - 30 MESH	1*
10	193679	ELBOW 1"	1
11	193672	ADAPTER 1-1/4" - 1"	1
12	MXA-C13ALM5	AIR FILTER 5µm + 1 REGULATOR	1*
	MXA-C13ACM5	AIR FILTER 5µm + 2 REGULATORS	1
13	193669	AIR HOSE	1
14	194224	ELBOW 1 1/2"	1
15	194225	NIPPLE 1 1/2" - 1"	1



## MX22060 & MX19070 WALL MOUNTED PUMP

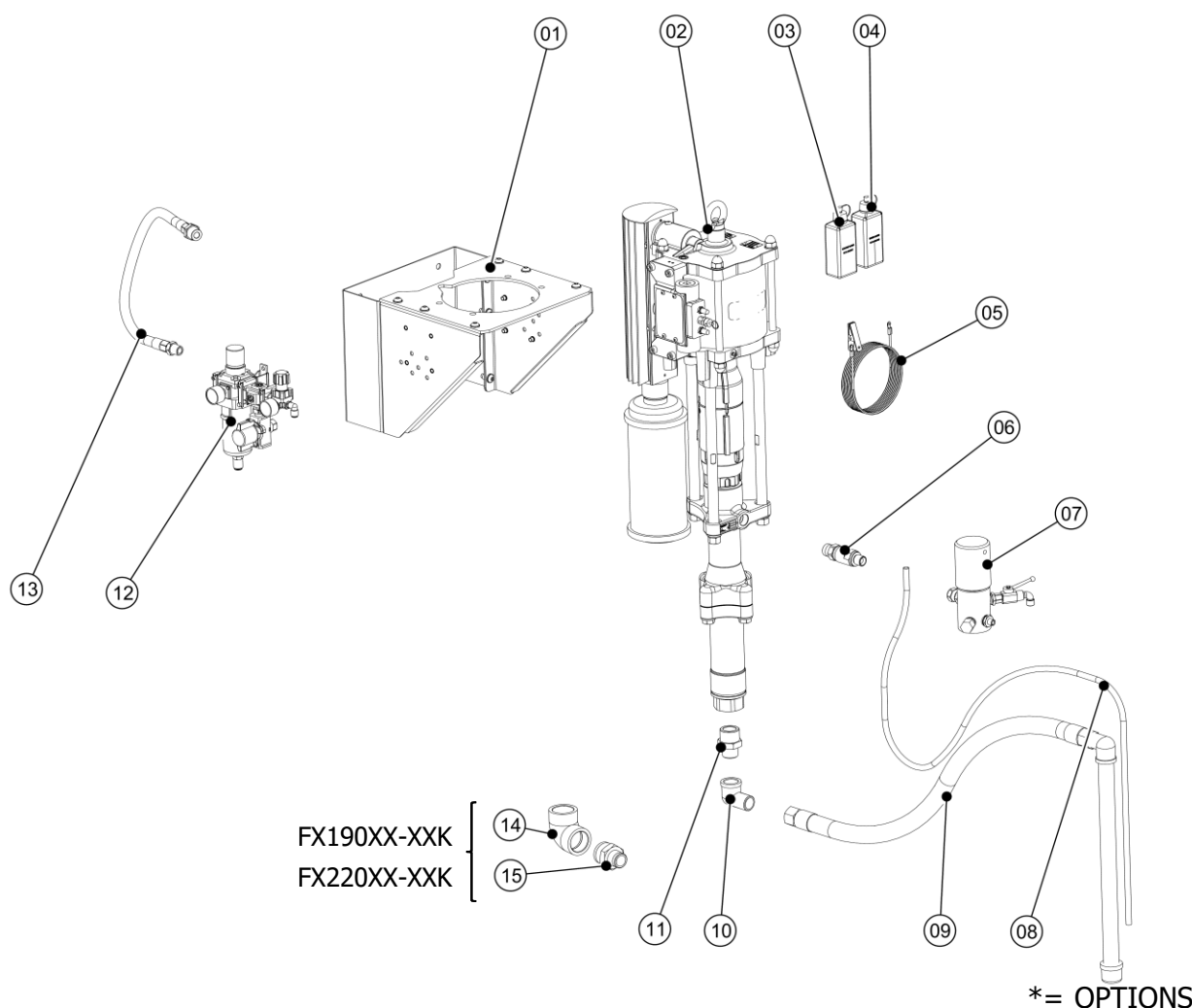

ITEM	PART NUMBER	DESCRIPTION	QTY
1	104095	WALL BRACKET	1
2	MX____-__	MX19042/22060 PUMP	1
3	0114-016099	LUBRICATION-SOLVENT BASED 0.25l	1
4	0114-016100	LUBRICATION-WATER BASED 0.25l	1
5	0114-011798	Grounding cable 4m	1
6	193791	CHECK VALVE	1
7	0114-011760	HP FILTER (100 mesh) TYPE 11	1
8	0110-009103	DUMP HOSE	2M
9	MXA-S25ME30	SUCTION HOSE ASSEMBLY 25 LITRE - 30 MESH	1
	MXA-S210ME30	SUCTION HOSE ASSEMBLY 210 LITRE - 30 MESH	1*
10	193679	ELBOW 1"	1
11	193672	ADAPTER 1-1/4" - 1"	1
12	MXA-C13ALM5	AIR FILTER 5µm + 1 REGULATOR	1*
	MXA-C13ACM5	AIR FILTER 5µm + 2 REGULATORS	1
13	193669	AIR HOSE	1
14	194224	ELBOW 1 1/2"	1
15	194225	NIPPLE 1 1/2" - 1"	1

ACCESSORIES

0114-011760  
TYPE 11 FILTER

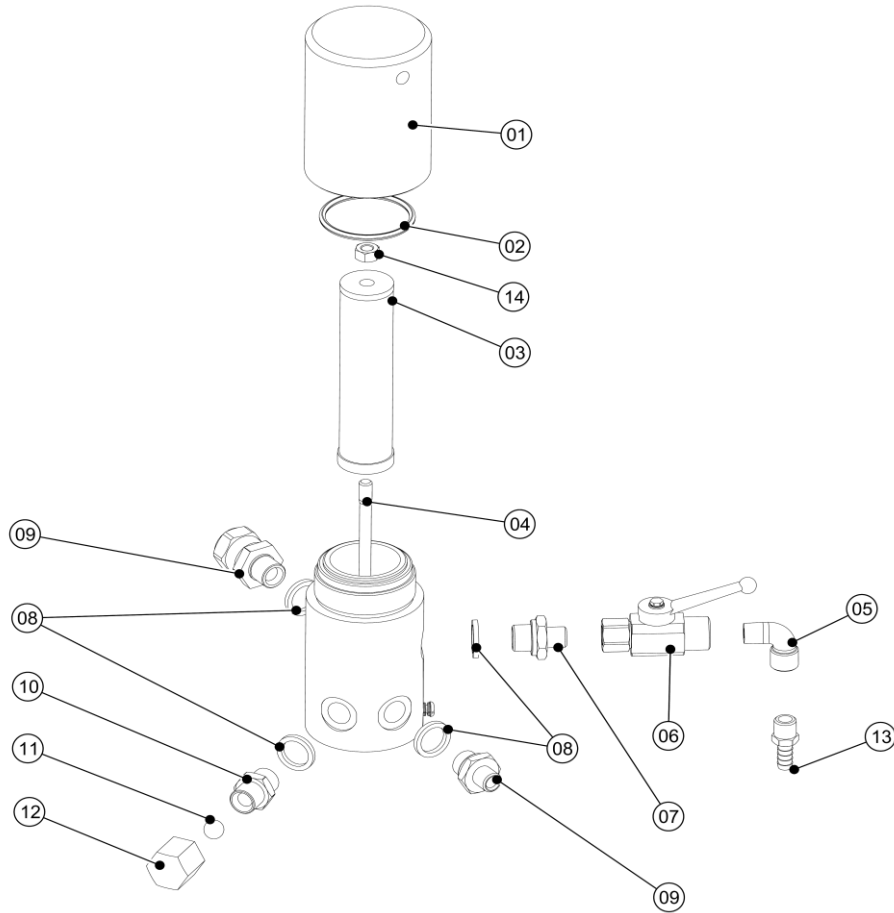

ITEM	PART NO	DESCRIPTION	QTY
1	0114-013848	FILTER CAP	1
2	0114-013850	SEAL	1
3	0114-014917	FILTER SCREEN 30 MESH (BLUE)	1
	0114-014886	FILTER SCREEN 50 MESH (ORANGE)	
	0114-014884	FILTER SCREEN 70 MESH (YELLOW)	
	0114-014883	FILTER SCREEN 100 MESH (BLACK) STANDARD	
	0114-014882	FILTER SCREEN 150 MESH (RED)	
	0114-014881	FILTER SCREEN 200 MESH (NATURAL)	
4	0114-013849	THREADED BOLT	1
5	0114-014085	ELBOW	1
6	0114-014087	BALL VALVE	1
7	0114-013855	NIPPLE	1
8	0114-013952	SEALING RING	4
9	0114-013638	ADAPTER 3/8" (M) x M22x1.5 (F)	1
10	0114-013780	NIPPLE	1
11	0114-014023	BALL	1
12	0114-013799	DOME NUT	1
13	0114-019985	HOSE CONNECTOR	1
14	0114-014546	NUT	1

## ACCESSORIES

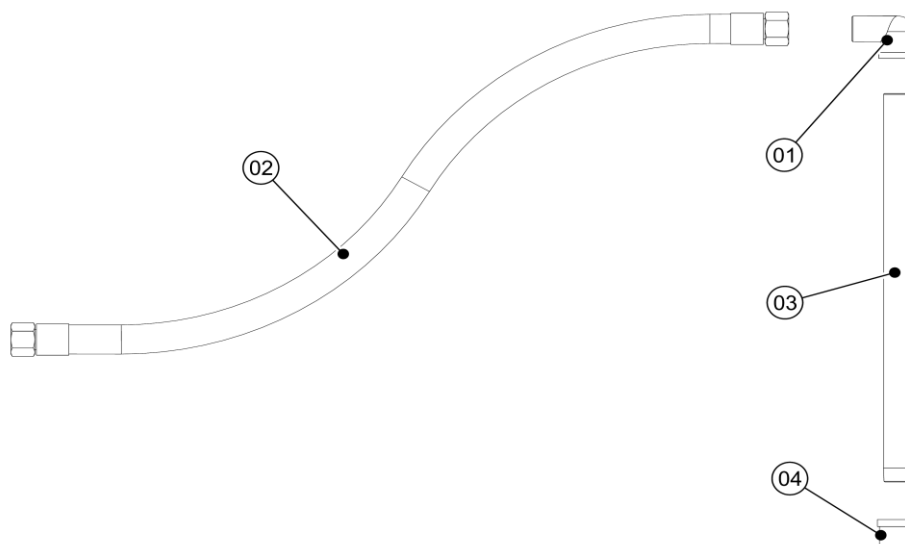
**MXA-S25ME30 & MXA-S210ME30  
SUCTION HOSE ASSEMBLIES**

ITEM	PART NO	DESCRIPTION	QTY
1	193679	ELBOW 1"	1
2	193673	HOSE 1" BSP x 1m LG (25L)	1
	193674	HOSE 1" BSP x 2m LG (210L)	1
3	0114-013767	1" TUBE x 0.5m LG (25L)	1
	193675	1" TUBE x 1m LG (210L)	1
4	193671	FILTER 30 MESH	1

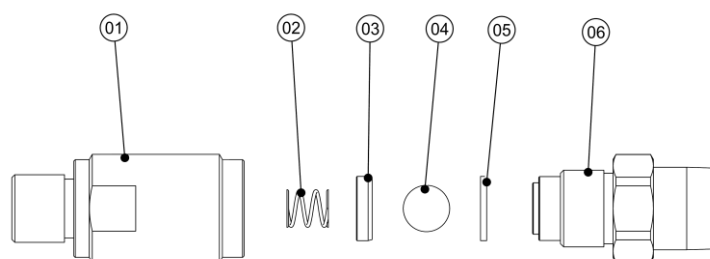
**193791  
CHECK VALVE**

ITEM	PART NO	DESCRIPTION	QTY
1	193792	VALVE BODY	1
2	193795	SPRING	1
3	0114-014237	BALL Ø15	1
4	0114-014056	SEAT	1
5	193794	SEAL	1
6	193793	NIPPLE	1

## ACCESSORIES

### 193381 HOSE BRACKET

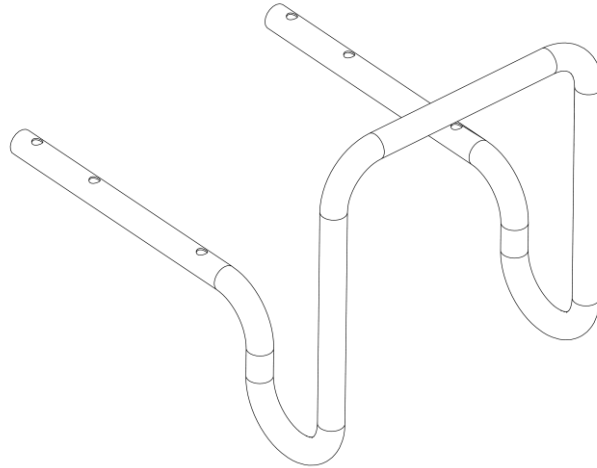

### PUMP LUBRICATION

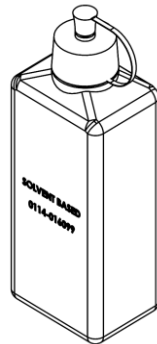

ITEM	PART NO	DESCRIPTION	QTY
1	0114-016099	LUBRICATION-SOLVENT BASED 0.25l	1
2	0114-016100	LUBRICATION-WATER BASED 0.25l	1
3	0114-014871	LUBRICATION-WATER BASED 0.5l	1
4	0114-009433	LUBRICATION-SOLVENT BASED 0.5l	1

**NOTES**

**NOTES**

**NOTES**

## **WARRANTY POLICY**

Binks products are covered by Carlisle Fluid Technologies five year materials and workmanship limited warranty. The use of any parts or accessories, from a source other than Carlisle Fluid Technologies, will void all warranties. For specific warranty information please contact the closest Carlisle Fluid Technologies location listed below.

Carlisle Fluid Technologies reserves the right to modify equipment specifications without prior notice. DeVilbiss®, Ransburg®, MS®, BGK® and Binks® are registered trademarks of Carlisle Fluid Technologies, Inc.

© 2017 Carlisle Fluid Technologies, Inc.

All rights reserved.

Binks is part of Carlisle Fluid Technologies, a global leader in innovative finishing technologies. For technical assistance or to locate an authorized distributor, contact one of our international sales and customer support locations below.

### **USA/Canada**

www.binks.com  
info@carlisleft.com  
Toll Free Tel: 1-888-992-4657  
Toll Free Fax: 1-888-246-5732

### **Mexico**

www.carlisleft.com.mx  
ventas@carlisleft.com.mx  
Tel: 011 52 55 5321 2300  
Fax: 011 52 55 5310 4790

### **Brazil**

www.devilbiss.com.br  
vendas@carlisleft.com.br  
Tel: +55 11 5641 2776  
Fax: +55 11 5641 1256

### **United Kingdom**

www.carlisleft.eu  
info@carlisleft.eu  
Tel: +44 (0)1202 571 111  
Fax: +44 (0)1202 573 488

### **France**

www.carlisleft.eu  
info@carlisleft.eu  
Tel: +33(0)475 75 27 00  
Fax: +33(0)475 75 27 59

### **Germany**

www.carlisleft.eu  
info@carlisleft.eu  
Tel: +49 (0) 6074 403 1  
Fax: +49 (0) 6074 403 281

### **China**

www.carlisleft.com.cn  
mkt@carlisleft.com.cn  
Tel: +8621-3373 0108  
Fax: +8621-3373 0308

### **Japan**

www.ransburg.co.jp  
overseas-sales@carlisleft.co.jp  
Tel: 081 45 785 6421  
Fax: 081 45 785 6517

### **Australia**

www.carlisleft.com.au  
sales@carlisleft.com.au  
Tel: +61 (0) 2 8525 7555  
Fax: +61 (0) 2 8525 7575



*SOLUTIONS FOR YOUR WORLD*