



**AUTOMOTIVE  
PAINT  
REPAIR PROCESS  
EQUIPMENT,  
SERVICE AND  
DESIGN**

Your Single Source For Proprietary & Proven Electric Infrared Products And Paint Line Solutions

**BGK AutoCure™**



**3000**



**5000**



**6000**



**8000**

The BGK **AUTOCURE™** line of Infrared heaters provide users with a wide range of solutions to fit their production needs.

The BGK 3000, 5000, 6000 & 8000 models – available in a variety of heater head sizes – feature infrared control technology and provides easy maneuverability and accuracy for curing spot repairs.

The BGK Model 6000 overhead heater is specifically designed for overhead XY gantry mounting, each unit includes an

electric linear actuator the operator uses for flexible heater positioning prior to the drying process.

AutoCure heaters meet or exceed all standards for wiring, testing and construction and are the industry leaders when it comes to critical curing performance and reliability.

### AutoCure™ 3000 Portable Heater

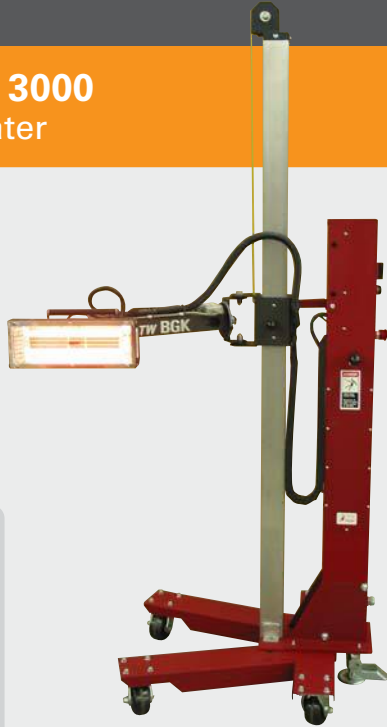

Can be configured for

- Cars
- SUV's, Trucks
- Commercial Trucks

### AutoCure™ 5000 Portable Heater

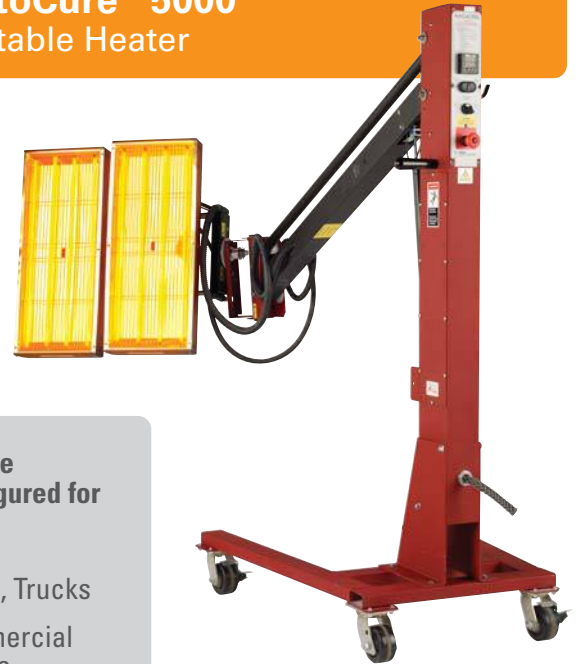

Can be configured for

- Cars
- SUV's, Trucks
- Commercial Trucks

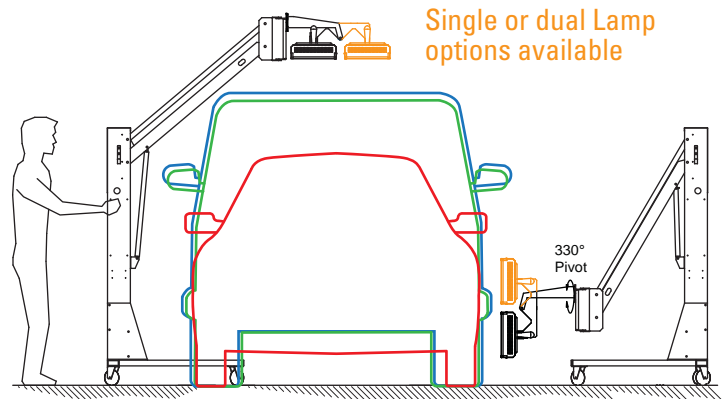
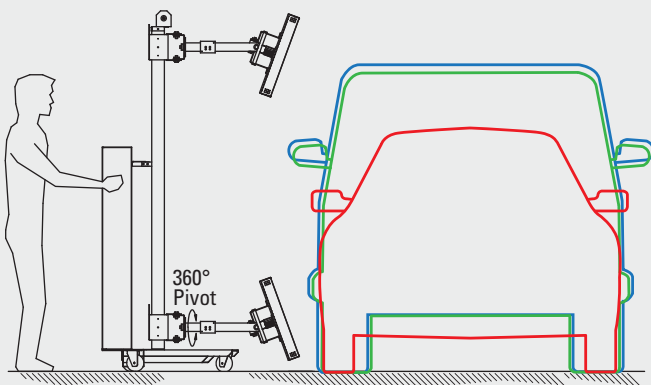

## INFRARED EMITTERS

BGK Infrared Emitters incorporate unique shortwave T3 emitters exclusively manufactured for BGK equipment. Providing the most efficient heat transfer – direct and penetrating – BGK T3 emitters maximize your process and productivity.

Halogen gas filled clear quartz tubes include tantalum discs, tungsten

filaments, stainless steel leads and durable ceramic end seals, BGK Emitters provide direct, reflected and convective energy spanning all wavelengths. Rated with 5,000 hour lamp life, proprietary BGK systems routinely experience lamp life of 10,000 hours or more delivering great value.

- Accurate surface temperature control to  $\pm 5^{\circ}\text{F}$
- Automatic control
- Laser Spot Sensor – Position Temperature Indicator
- Power assisted raise and lower
- Cycle-time-remaining display
- Automatic timed shut-off
- Heater head remains in place without locking handles
- Single or dual temperature setpoint capability
- Adjustable time temperature heat cycles
- Heating range to  $400^{\circ}\text{F}$  ( $204^{\circ}\text{C}$ )
- Locking mechanism to maintain arm position
- Adjustable controlled ramp rates to setpoint

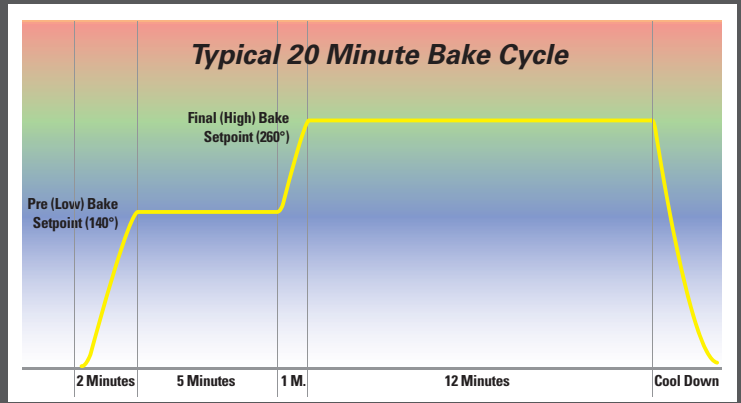

## AutoCure™ 6000 Overhead Gantry Mounted Heater



Can be configured for

- Cars
- SUV's, Trucks
- Commercial Trucks

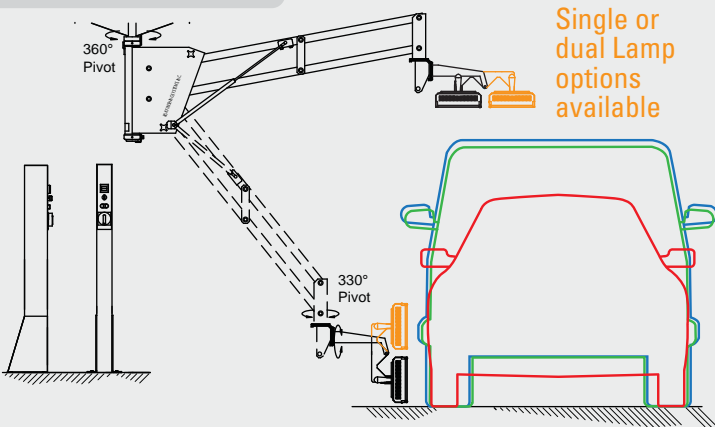

## AutoCure™ 8000 Portable Panel Heater



Can be configured for

- Cars
- SUV's, Trucks
- Commercial Trucks

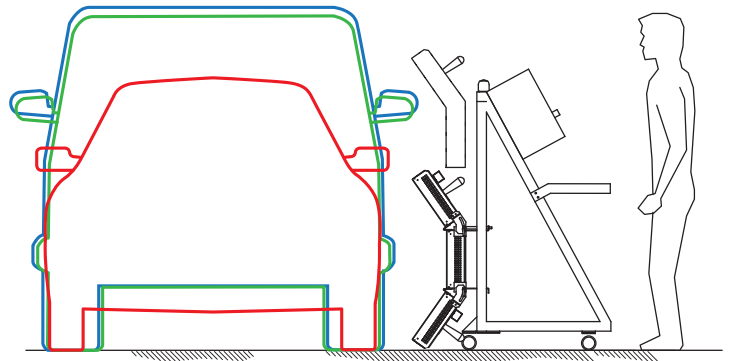

BGK Systems Routinely  
Experience Lamp Life Of  
10,000 Hours And More!

BGK. Committed To The Worlds  
Highest Manufacturing Standards!



## Technological Innovation Drives World-Wide Leadership

BGK is the world-wide leader in designing, fabricating and installing electric infrared curing systems for a full range of coatings operations. Whether coating with liquid, powder, PTFE, wax, UV or adhesives, BGK provides curing systems for superior quality finishes.

BGK Infrared advantages include reduced energy consumption, efficient use of floor space and increased productivity. BGK customers receive turnkey system capabilities including process verification, and after the sale service, installation, start-up and training.



***Curing Paint...It's What We Do.***

### ***BGK Offers:***

- Chain-On-Edge Conveyor Systems
- Infrared Booster Ovens
- Flatline Conveyor Systems
- Overhead Conveyor Systems
- Infrared Heater Modules
- Coil Coating Systems
- IR Smart Lab Ovens
- Automotive Repair Ovens
- Automotive Portable Infrared Repair Arms
- Comprehensive Testing

**[www.binks.com](http://www.binks.com)**  
**[www.devilbiss.com](http://www.devilbiss.com)**  
**[www.ransburg.com](http://www.ransburg.com)**  
**[www.bgk.com](http://www.bgk.com)**

**Illinois**  
195 Internationale Blvd.  
Glendale Heights, IL 60139  
  
Phone: 630-237-5000  
Fax: 630-237-5003

**Ohio**  
320 Phillips Ave.  
Toledo, OH 43612  
  
Phone: 419-470-2000  
Fax: 419-470-2233

**Minnesota**  
4131 Pheasant Ridge Drive, N.E.  
Minneapolis, MN 55449  
  
Phone: 763-784-0466  
Fax: 763-784-1362